

# Product Improvement

## Mark IV Pump Control Kit

Part # 5041535

### Improving Machine Velocity by Increasing Machine Uptime

#### SUMMARY

The Harsco Rail Pump Control Kit is focused on improving production velocity by increasing machine uptime. Independent pump controls allows mechanics to quickly identify failing or worn pumps and helps in setting up new pumps. In-line filtration reduces the chance of contaminants entering the control valves, increasing the overall life of the valve.

#### Benefits

- Independent pump control
- Improves trouble shooting in the field
- Reduces setup time
- Improved control valve life



Current Design

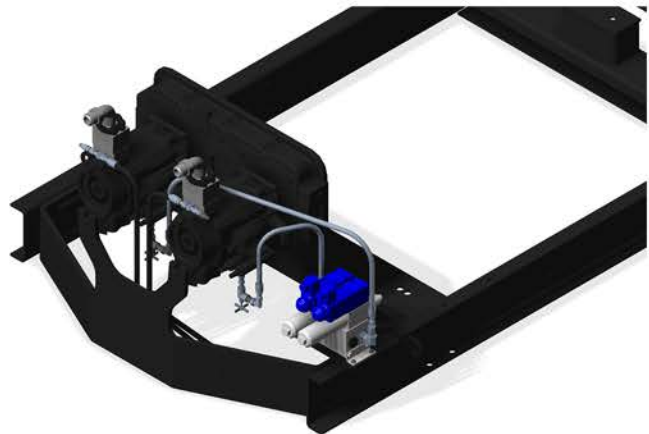

New Design

2401 Edmund Road  
West Columbia, SC 29171 USA  
Tel: (803) 822-9160 Fax: (803) 822-8107  
Email: [railparts@harsco.com](mailto:railparts@harsco.com)  
[www.harscorail.com](http://www.harscorail.com)

**HARSCO**  
RAIL