

HARSCO

RAIL

www.harscorail.com

SERVICE BULLETIN MAINTENANCE OF WAY EQUIPMENT

DATE: 11-2016

BULLETIN NO: 16-008

TITLE: Gearbox-Motor Spline Maintenance

RATING:



DIRECTIVE
(Action Is Required)



ALERT
(Potential Problem)



INFORMATION
(Action Is Optional)



PRODUCT IMPROVEMENT
(Enhance Product)

PRODUCT SERIES / MODEL: GO4S-III-CN-SH UNDERCUTTER

SERIAL NO: 4711654

SUMMARY: Instructions to clean, inspect, and apply anti-seize protection to gearbox spline connections.

OPERATIONAL IMPACT: Spline connection at the Travel Traction motor and gearbox of each axle could fret, corrode, wear, or otherwise fail unless proper lubrication procedures are followed at recommended maintenance intervals.

ACTION: Follow the instructions in this Service Bulletin to maintain the spline connections of the gearbox and Travel Traction motors at the suggested maintenance intervals.

CONTACT: Harsco Rail Service Department
Columbia, SC Facility
(803) 822-7546



INFORMATION

- FOLLOW APPLICABLE RAILROAD LOCKOUT - TAGOUT PROCEDURE TO DISABLE ENERGY SOURCES WHEN PERFORMING MAINTENANCE, MAKING ADJUSTMENTS OR REPAIRS TO THE EQUIPMENT. FAILURE TO HEED THIS WARNING COULD RESULT IN SEVERE BODILY INJURY.

GEAR BOX AND TRACTION MOTORS - SPLINE MAINTENANCE

Every 500 hours or every six months, whichever comes first, the Travel Traction hydraulic motor at each axle should be removed and the male and female spline connections should be cleaned and inspected for fretting, corrosion, wear etc. When re-assembled, the male and female splines should be coated with a layer of anti-seize protection to help prevent spline damage from fretting, corrosion, wear etc.

1. Remove fasteners and Travel Traction hydraulic motor.
2. Clean the male and female splines (1) with mineral spirits and wipe with a clean cloth.

Note: Ensure that the nearby bearings do not get contaminated with debris while cleaning splines or applying new anti-seize compound.

3. Thoroughly apply a layer of anti seize protection (Loctite LB 8150 Silver Grade or equivalent) to the male and female splines (1).
4. Re-install Travel Traction hydraulic motor and secure with fasteners.

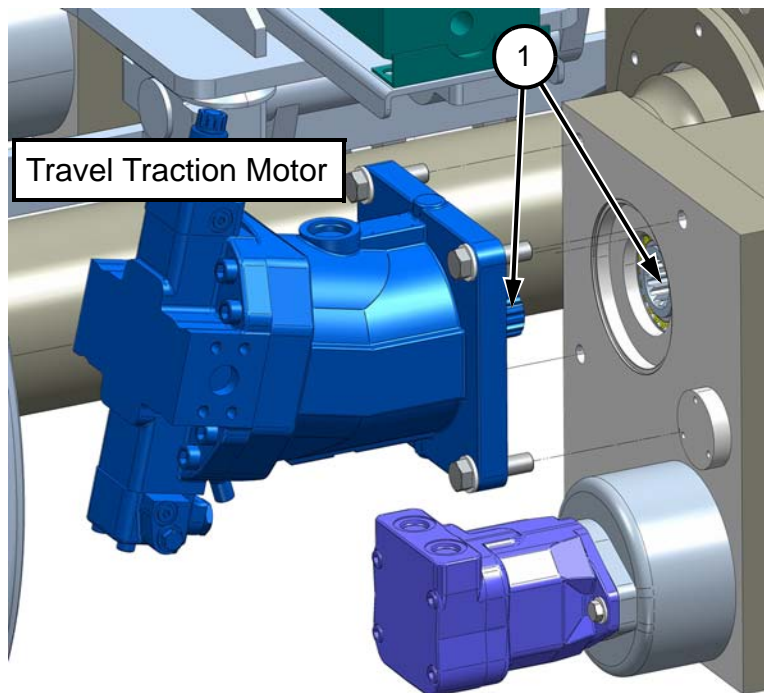
**GEARBOX AND TRACTION MOTOR
SPLINE INSPECTION AND PREVENTIVE MAINTENANCE**

© 2016 HARSCO CORPORATION, ALL RIGHTS RESERVED

415 North Main Street
Fairmont, MN
56031-1837
Tel: (507) 235-3361
Fax: (507) 235-7370

2401 Edmund Road, Box 20
Cayce-West Columbia, SC
29171-0020
Tel: (803) 822-9160
Fax: (803) 822-7471

200 South Jackson Road
Ludington, MI
49431
Tel: (231) 843-3431
Fax: (231) 843-1644

Printed In USA