



www.harscorail.com

---

## SERVICE BULLETIN

### MAINTENANCE OF WAY EQUIPMENT

---

**DATE:** 03-2017

**BULLETIN NO:** 17-003

**TITLE:** Visual Gearbox Position Indicators

**RATING:**

<input type="checkbox"/>	<b>DIRECTIVE</b> (Action Is Required)	<input checked="" type="checkbox"/>	<b>ALERT</b> (Potential Problem)
<input type="checkbox"/>	<b>INFORMATION</b> (Action Is Optional)	<input type="checkbox"/>	<b>PRODUCT IMPROVEMENT</b> (Enhance Product)

**PRODUCT SERIES / MODEL:** GO4S-III-CN-SH UNDERCUTTER

**SERIAL NO:** 4711654

**SUMMARY:** The Jupiter II interface panels display the gearbox status - whether the gearboxes are in Low, Neutral or High gear. Another method is available to ensure which position the gearbox is in. All gearboxes on the Undercutter have a visual position indicator - a shaft that protrudes from the side of the unit. The amount the shaft protrudes is different for each gearbox position. This service bulletin describes how to determine the gearbox position using the visual position indicator.

**OPERATIONAL IMPACT:** When the Undercutter is to be towed by a locomotive or other piece of equipment, all gearboxes on the Undercutter must be in the Neutral position prior to coupling and while being towed. If any of the gearboxes are not in the Neutral position prior to coupling and when being towed, damage to the gearbox will be incurred.

**ACTION:** Refer to the procedures in this Service Bulletin to visually inspect the gearbox position indicator to determine if the unit is in gear or in the neutral position.

**CONTACT:** Harsco Rail Service Department  
Columbia, SC Facility  
(803) 822-7546

**SAFETY INFORMATION**

- FOLLOW APPLICABLE RAILROAD LOCKOUT - TAGOUT PROCEDURE TO DISABLE ENERGY SOURCES WHEN PERFORMING MAINTENANCE, MAKING ADJUSTMENTS OR REPAIRS TO THE EQUIPMENT.
- PRIOR TO PERFORMING MAINTENANCE TASKS, APPLY PARKING BRAKES, STOP ENGINE AND TURN MASTER DISCONNECT SWITCH OFF.

**FAILURE TO HEED THESE WARNINGS COULD RESULT IN SEVERE BODILY INJURY.**

**DETERMINING GEARBOX STATUS WITH THE VISUAL INDICATOR -**

See Figures 1 through 3

Prior to towing the machine, follow the procedure below.

1. Check to make sure that the Hand Brakes at both ends of the machine are applied.
2. Apply wheel chocks as required.
3. Secure ALL work components. Digging Wheels, Undercutter Bars and all Conveyors should be properly stored in their respective locks and rests. Stow all equipment, including the Trip Wire System.
4. With the proper panel in Jupiter, place all Gearboxes in the Neutral position.
5. Shutdown the machine.
6. Observe the Visual Gearbox Indicator found on each gearbox to ensure the machine is in Neutral Position as in Figure 2.
  - (1) If the Indicator Shaft fills the observation window - the gearbox is in **Low Gear** - see Figure 1.
  - (2) If the end of the Indicator Shaft is visible in the observation window, the gearbox is in **Neutral** - see Figure 2.
  - (3) If the Indicator Shaft is not visible in the observation window - the gearbox is in **High Gear** - see Figure 3.
7. If all Gearboxes are visually observed to be in Neutral, the machine can be safely towed.
8. If any Gearbox is visually observed to NOT be in the Neutral position, DO NOT TOW the machine until the gearbox(es) can be placed in the Neutral Position.

**DETERMINING GEARBOX STATUS WITH THE VISUAL INDICATOR -**

See Figures 1 through 3

FIGURE 1  
GEARBOX IN **LOW GEAR** -  
(INDICATOR SHAFT FILLS VIEWING WINDOW)

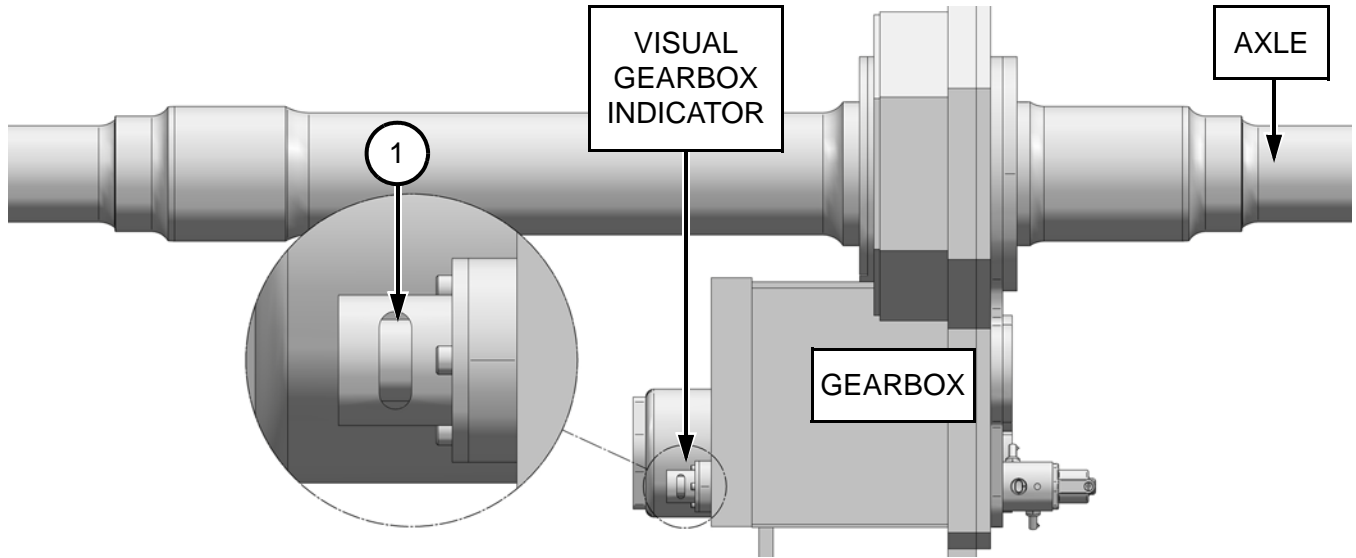
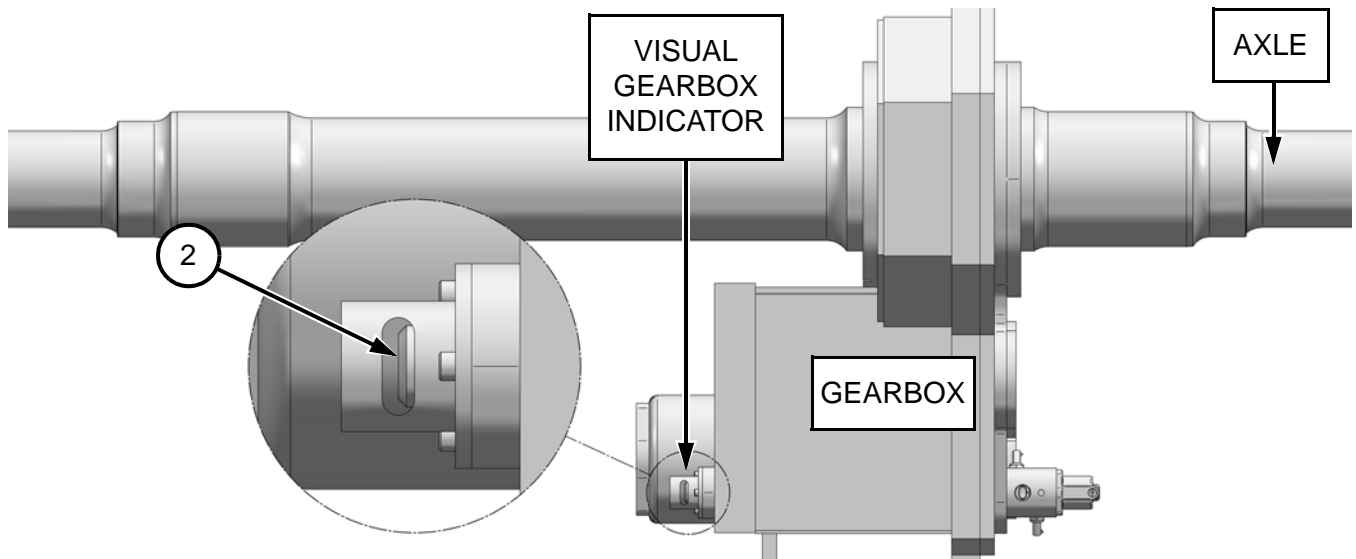

FIGURE 2  
GEARBOX IN **NEUTRAL** -  
(END OF INDICATOR SHAFT VISIBLE IN VIEWING WINDOW)



**DETERMINING GEARBOX STATUS WITH THE VISUAL INDICATOR -**

See Figures 1 through 3

**FIGURE 3**  
**GEARBOX IN HIGH GEAR -**  
**(INDICATOR SHAFT NOT VISIBLE IN VIEWING WINDOW)**

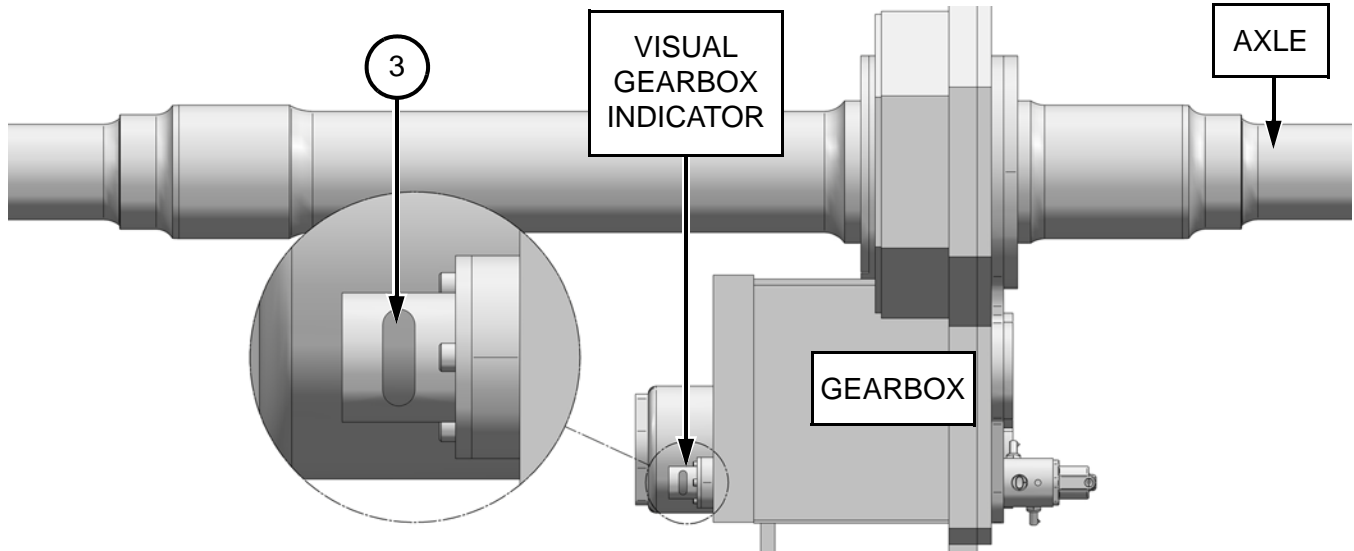

**© 2017 HARSCO CORPORATION, ALL RIGHTS RESERVED**

306 West 4th Street  
Fairmont, MN  
56031-1837  
Tel: (507) 235-7376  
Fax: (507) 235-7372

2401 Edmund Road, Box 20  
Cayce-West Columbia, SC  
29171-0020  
Tel: (803) 822-9160  
Fax: (803) 822-7403

200 South Jackson Road  
Ludington, MI  
49431  
Tel: (231) 843-3431  
Fax: (231) 843-1644

Printed In USA