



www.harscorail.com

SERVICE BULLETIN

MAINTENANCE OF WAY EQUIPMENT

DATE: 09-2019

BULLETIN NO: 19-006

TITLE: Safe Turn Alert Part Number Change

RATING:

<input type="checkbox"/>	DIRECTIVE (Action Is Required)	<input type="checkbox"/>	ALERT (Potential Problem)
<input checked="" type="checkbox"/>	INFORMATION (Action Is Optional)	<input type="checkbox"/>	PRODUCT IMPROVEMENT (Enhance Product)

PRODUCT SERIES / MODEL: PT-0080 Safe Turn Alert

SERIAL NO: N/A

SUMMARY: Protran Technology changed the part number for the Safe Turn Alert Unit. The obsolete part number is PT-008000. The new part number is PT-0080. Use the new part number when ordering Safe Turn Alert Units.

If an order is placed using the old part number, the packing list will not match the Purchase Order.

OPERATIONAL IMPACT: None

ACTION: For all new orders of the Safe Turn Alert units, use part number PT-0080.

Contact Protran Technology for questions or to verify the correct part number for the order.

CONTACT: Protran Technology Service Department
Columbia, SC Facility
(973) 250-4176
(973) 862-6220

Part number change Information

1. Protran Technology has changed the part number of the Safe Turn Alert (STA) unit. For future or replacement orders, use the new part number: PT-0080.
2. The new model PT-0080 has two M12 connectors on the back of the unit for Blind Spot Awareness feature as shown in the Figure 1.

FIGURE 1
PT-0080 SAFE TURN ALERT

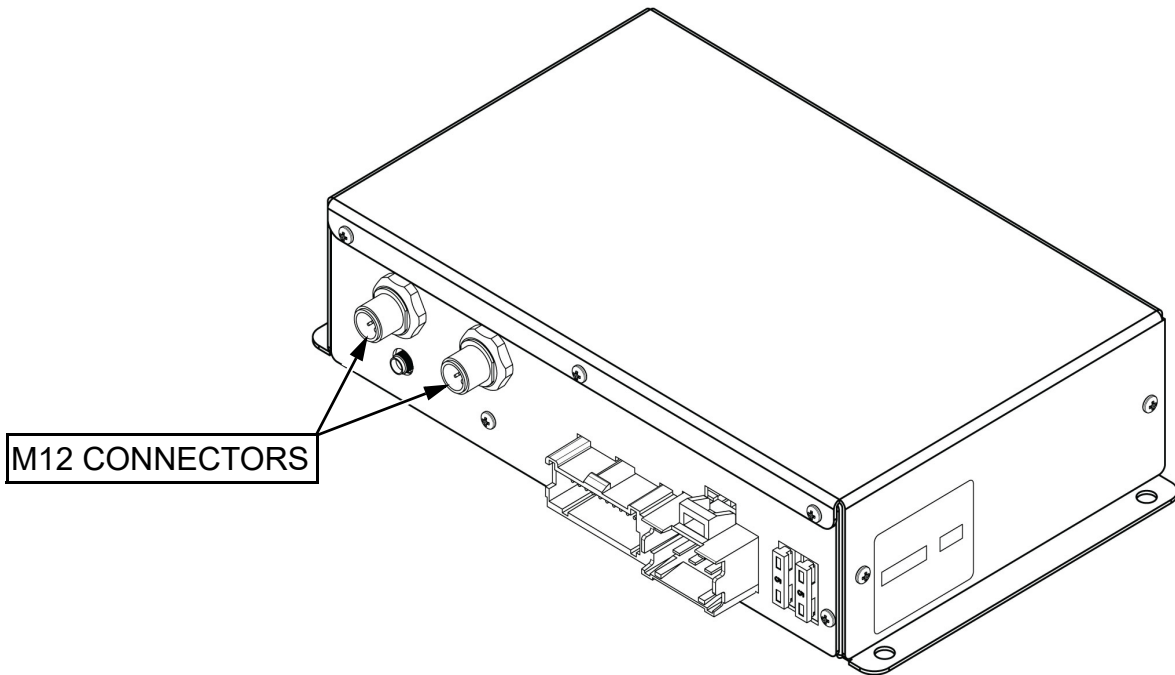

© 2019 HARSCO CORPORATION, ALL RIGHTS RESERVED

306 West 4th Street
Fairmont, MN
56031-1837
Tel: (507) 235-7376
Fax: (507) 235-7372

2401 Edmund Road, Box 20
Cayce-West Columbia, SC
29171-0020
Tel: (803) 822-9160
Fax: (803) 822-7403

200 South Jackson Road
Ludington, MI
49431
Tel: (231) 843-3431
Fax: (231) 843-1644

Printed In USA