



Harsco Track Technologies

Harsco

www.harscotrack.com

SERVICE BULLETIN MAINTENANCE OF WAY EQUIPMENT

DATE: 8-28-2003 **BULLETIN NO:** 03-015

TITLE: PUMP DRIVE SHAFT SEALS

RATING:

<input type="checkbox"/>	DIRECTIVE (Action Is Required)	<input type="checkbox"/>	ALERT (Potential Problem)
<input checked="" type="checkbox"/>	INFORMATION (Action Is Optional)	<input type="checkbox"/>	PRODUCT IMPROVEMENT (Enhance Product)

PRODUCT SERIES / MODEL: 6700S Tampers

SERIAL NO: All Models Serial # 153045 and Higher

SUMMARY: There has been a recent change in the Pump Drive for the Model 6700S Tamper. The seals have been upgraded from a standard Buna-N seal material to a Viton material that is rated to operate at higher temperatures. The pump drive can experience 200 degrees F during operation. The Buna-N seal can operate at temperatures up to 250 degrees F, while the Viton seal can operate at temperatures up to 400 - 450 degrees F.

OPERATIONAL IMPACT: To improve machine reliability and extend the service life of the pump drive shaft seals.

ACTION: When replacement seals part # 171522-1 are ordered, a complete kit of four seals will be shipped under the same part number. This quantity is sufficient to replace the input and all of the output shaft seals in the pump drive.

CONTACT: If you have any questions or if we can be of any service, please contact Bill Perry at the Ludington, MI. facility, (231) 843-3431.

PARTS LIST

Note: See Figure 1 for Item Numbers

ITEM	PART NO	DESCRIPTION	QTY
1	171522-1	Shaft Seal Kit - Input and Output	1

**FIGURE 1
PUMP DRIVE SHAFT SEALS**

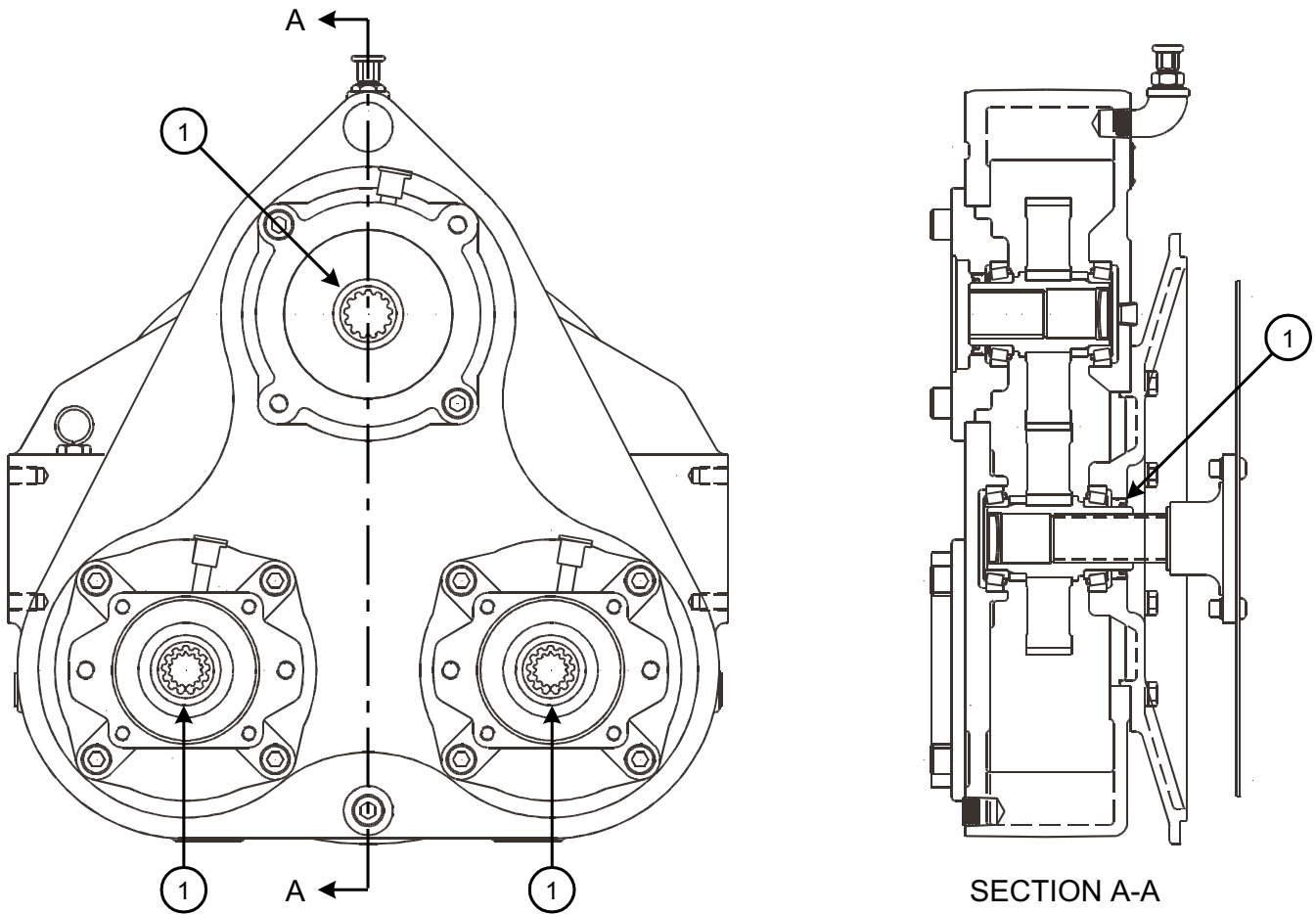

© 2003 HARSCO TRACK TECHNOLOGIES, HARSCO CORPORATION

415 North Main Street
Fairmont, MN
56031-1837
Tel: (507) 235-3361
Fax: (507) 235-7370

2401 Edmund Road, Box 20
Cayce-West Columbia, SC
29171-0020
Tel: (803) 822-9160
Fax: (803) 822-7471

200 South Jackson Road
Ludington, MI
49431
Tel: (231) 843-3431
Fax: (231) 843-4830