

# **HTT**

## **Harsco Track Technologies**

---

**Harsco**

**HR3000 SERIES C2  
FRONT UNIVERSAL HY-RAIL®  
GUIDE WHEEL UNIT  
HYDRAULICALLY OPERATED**

**OPERATOR'S SERVICE  
AND PARTS MANUAL**

ISSUED 10 - 2006

BULLETIN 1526

© 2006 HARSCO TRACK TECHNOLOGIES, HARSCO CORPORATION



■ **THIS MANUAL CONTAINS VITAL INFORMATION FOR THE SAFE USE AND EFFICIENT OPERATION OF THE VEHICLE EQUIPPED WITH HY-RAIL® GUIDE WHEEL EQUIPMENT. CAREFULLY READ THIS OPERATOR'S MANUAL BEFORE USING THE VEHICLE. FAILURE TO ADHERE TO THE INSTRUCTIONS COULD RESULT IN BODILY INJURY AND/OR PROPERTY DAMAGE.**

HY-RAIL® is a registered trademark of Harsco Track Technologies, Harsco Corporation.

When this manual is received, record the guide wheel unit serial numbers in the spaces provided in the General Information and Parts Sections for future reference, in case the serial number tags ever become unreadable. A Manual must remain with the vehicle. Additional or replacement manuals may be obtained by calling or writing Harsco Track Technologies, Harsco Corporation.

All information, illustrations and specifications in this manual are based on the latest information available at the time of publication. Harsco Track Technologies, Harsco Corporation reserves the right to make changes at any time without notice.

## **FACILITY LOCATIONS**

### **Harsco Track Technologies**

415 North Main Street  
Fairmont, MN  
56031-1837

Tel: (507) 235-3361

Fax: (507) 235-7370

### **Harsco Track Technologies**

200 South Jackson Road  
Ludington, MI  
49431

Tel: (231) 843-3431

Fax: (231) 843-4830

### **Harsco Track Technologies**

2401 Edmund Road, Box 20  
Cayce-West Columbia, SC  
29171-0020

Tel: (803) 822-9160

Fax: (803) 822-7471

### **Harsco Track Technologies**

Giltway, Giltbrook  
Nottingham, NG16 2GQ  
England

Tel: 0115 938 7000

Fax: 0115 938 7001

### **Harsco Track Technologies**

4 Strathwyn Street, PO Box 5287  
Brendale, Queensland 4500  
Australia

Tel: 61 7 205 6500

Fax: 61 7 205 7369

# TABLE OF CONTENTS

GENERAL INFORMATION	SECTION	1
OPERATION	SECTION	2
ADJUSTMENTS	SECTION	3
MAINTENANCE	SECTION	4
TROUBLESHOOTING	SECTION	5
PARTS	SECTION	6
VEHICLE APPLICATIONS	SECTION	7
CONVERSION TABLES	APPENDIX	A
SAE J1273	APPENDIX	B



**SECTION 1 - GENERAL INFORMATION**  
**TABLE OF CONTENTS**

1.1	Safety Information . . . . .	1 - 2
1.1.1	Hazard Seriousness . . . . .	1 - 2
1.2	Description . . . . .	1 - 5
1.3	Vehicle Orientation . . . . .	1 - 5
1.4	Serial Numbers . . . . .	1 - 6
1.5	Specifications . . . . .	1 - 6
1.5.1	Vehicle . . . . .	1 - 6
1.5.2	Guide Wheel Unit . . . . .	1 - 6

## 1.1 Safety Information



SAFETY IS A CRITICAL FACTOR IN THE DESIGN OF HARSCO TRACK TECHNOLOGIES EQUIPMENT. THE BEST SAFETY PROGRAM STARTS WITH A SAFETY CONSCIOUS OPERATOR. THE SAFETY INFORMATION HIGHLIGHTED IN THIS BULLETIN DESCRIBES SAFE OPERATING PRACTICES FOR THE BENEFIT OF THE WORKERS WHO WILL USE OUR EQUIPMENT IN THEIR DAILY JOBS.

### 1.1.1 Hazard Seriousness

Signal Words: **DANGER**, **WARNING** and **CAUTION** are used to identify levels of hazard seriousness.



**DANGER** - Immediate hazards which WILL result in severe bodily injury or death.



**WARNING** - Hazards or unsafe practices which COULD result in severe bodily injury or death.



**CAUTION** - Hazards or unsafe practices which COULD result in minor bodily injury and / or product or property damage.

## 1.1 Safety Information



- **APPLY THE VEHICLE PARKING BRAKE AND STOP THE ENGINE WHEN PERFORMING MAINTENANCE, MAKING ADJUSTMENTS, WORKING UNDER VEHICLE OR GUIDE WHEEL EQUIPMENT OR WHENEVER UNINTENDED MOVEMENT OF THE VEHICLE COULD OCCUR, UNLESS OTHERWISE INSTRUCTED IN THIS MANUAL.**
- **MAKE SURE ALL PERSONS ARE CLEAR OF VEHICLE BEFORE PERFORMING ANY OPERATING FUNCTIONS.**
- **KEEP ALL PARTS OF THE BODY AND LOOSE CLOTHING CLEAR OF ALL MOVING PARTS OF THE VEHICLE OR GUIDE WHEEL EQUIPMENT.**
- **UNDERSTAND EQUIPMENT OPERATION AND BE AWARE OF ALL PINCH POINTS BEFORE OPERATING OR MAKING ADJUSTMENTS TO GUIDE WHEEL EQUIPMENT.**
- **IF A DERAILMENT SHOULD OCCUR WHILE VEHICLE IS OPERATING IN ELECTRIFIED 3RD-RAIL TERRITORY, VEHICLE OR GUIDE WHEEL EQUIPMENT MIGHT BE IN ELECTRICAL CONTACT WITH ELECTRIFIED RAIL. DO NOT ATTEMPT TO EXIT FROM VEHICLE UNTIL ELECTRICAL POWER TO 3RD-RAIL HAS BEEN TURNED OFF.**
- **DO NOT EXCEED 25 MPH (40 km/h) WHEN OPERATING VEHICLE ON TRACK. RAILROAD RULES GOVERNING SPEEDS SHOULD BE OBSERVED AT ALL TIMES. REDUCE SPEED WHEN PROPELLING VEHICLE THROUGH SWITCHES, CROSSINGS, BRANCH LINES AND ANY SPECIAL TRACK WORKS. OPERATING VEHICLE AT UNSAFE SPEEDS COULD RESULT IN DERAILMENT OF VEHICLE.**
- **CHECK AND CORRECT GUIDE WHEEL EQUIPMENT ALIGNMENT PROMPTLY IF MISALIGNMENT IS INDICATED.**

## 1.1 Safety Information

1



■ **AT MAXIMUM LOADED GROSS VEHICLE WEIGHT ON TRACK (including driver, passengers, equipment, tools, payload, etc.) DO NOT EXCEED ANY OF THE FOLLOWING:**

- **VEHICLE'S G.V.W.R. (Gross Vehicle Weight Rating).**
- **VEHICLE'S FRONT G.A.W.R. (Gross Axle Weight Rating) OR THE FRONT GUIDE WHEEL UNIT RATED LOAD CAPACITY, WHICHEVER IS LOWER.**
- **VEHICLE'S REAR G.A.W.R. (Gross Axle Weight Rating) OR THE SUM OF THE REAR GUIDE WHEEL UNIT RATED LOAD CAPACITY PLUS (+) VEHICLE'S REAR TIRE/WHEEL RATED LOAD CAPACITY, WHICHEVER IS LOWER.**
- **COMPONENTS RATED LOAD CAPACITY:**
  - A. **TIRE MANUFACTURER'S RATED LOAD CAPACITY**
  - B. **VEHICLE'S WHEEL RATED LOAD CAPACITY**
  - C. **FRONT GUIDE WHEEL UNIT RATED LOAD CAPACITY:**
    - 13,000 lbs (5,897 kg)
    - 6,500 lbs (2,948 kg) maximum per guide wheel

**FAILURE TO HEED THESE WARNINGS COULD RESULT IN SEVERE BODILY INJURY.**



■ **OBSERVE AND FOLLOW ALL RAILROAD SAFETY RULES AND REGULATIONS.**

■ **KNOW THE POSITIONS AND FUNCTIONS OF ALL CONTROLS BEFORE ATTEMPTING TO OPERATE VEHICLE.**

■ **THIS GUIDE WHEEL EQUIPMENT IS DESIGNED WITH YOUR SAFETY IN MIND. NEVER DISCONNECT AND/OR ATTEMPT TO OVERRIDE SAFETY FEATURES.**

**FAILURE TO HEED THESE PRECAUTIONS COULD RESULT IN BODILY INJURY AND/OR PROPERTY DAMAGE.**

*Note: To help ensure safe operation of this equipment, keep all safety decals clean and legible. Replace safety decals when necessary with new decals, listed in the Parts Section of this manual.*



## 1.2 Description

The HR3000 Series C2 HY-RAIL® guide wheel equipment can be applied to the front of various cab chassis trucks with single or tandem rear axles and dual wheels. The vehicle's G.V.W.R. (gross vehicle weight rating) and/or G.A.W.R. (gross axle weight rating) must comply with specifications recommended by Harsco Track Technologies. For information regarding special applications, contact Harsco Track Technologies, Harsco Corporation, Fairmont, Minnesota.

The guide wheel unit is raised and lowered hydraulically. Hydraulic power may be supplied from the vehicle system or from an optional power pack. The guide wheel unit is mounted onto the vehicle frame. When the guide wheels are in the "highway" position, the weight of the guide wheel unit is carried on the vehicle frame, above the springs. Load bearing guide wheels assemblies guide the vehicle during on track operation. The guide wheel unit is designed to extend under the vehicle's front suspension, when in the "rail" position and lift the front of the vehicle, raising the front tires above the rails to ensure that the tires do not come into contact with the rails while the vehicle is propelling through crossings, switches, etc. The guide wheel unit utilizes the vehicle's suspension to support the vehicle front load when on track. A steering lock is used during on track operation. The steering lock holds the vehicle's steering wheel in place to ensure the vehicle's front tires remain straight.

The vehicle's rear inner dual wheels are used for propulsion on the track. On track braking is provided by the vehicle's rear brakes, the front guide wheel unit's brakes and the rear guide wheel unit's brakes, if so equipped. Since the guide wheel unit brakes are air actuated, the vehicle on which the guide wheel equipment is mounted should be equipped with air brakes. If not, an electric / air system is available to provide air for the guide wheel unit brakes.

## 1.3 Vehicle Orientation

Front - rear and left - right are determined from the vehicle operator's seat.

1

**1.4 Serial Numbers**

When this bulletin is received, complete the following record from the serial number tag on the guide wheel unit. Always provide these factory serial numbers when calling or writing about the unit. The serial number tag is located on the frame assembly of the unit.

FIGURE 1-1  
GUIDE WHEEL UNIT SERIAL NUMBER TAG

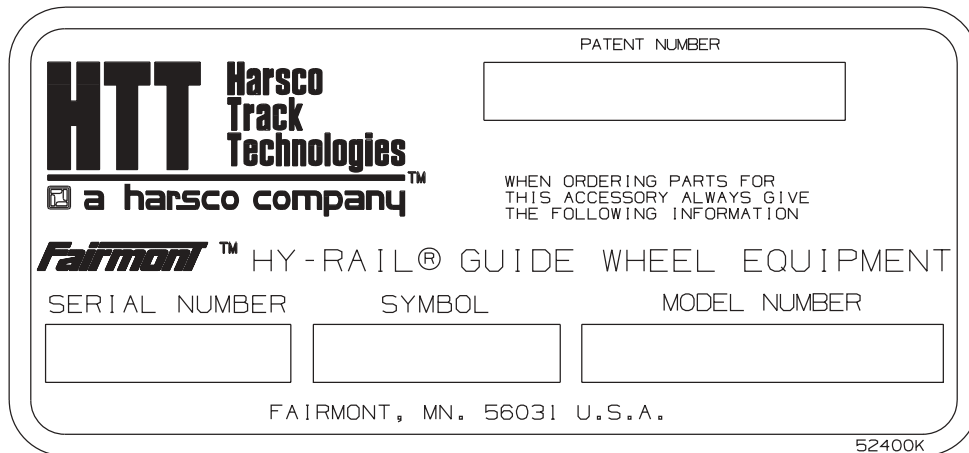

**1.5 Specifications**

**1.5.1 Vehicle**

The vehicle's G.V.W.R. (gross vehicle weight rating) and/or G.A.W.R. (gross axle weight rating) must comply with specifications recommended by Harsco Track Technologies. For information regarding special applications, contact Harsco Track Technologies, Harsco Corporation, Fairmont, Minnesota.

**1.5.2 Guide Wheel Unit**

Track Gauge .....	56-1/2 in	(1435 mm)
Guide Wheels - Flange Diameter .....	14-3/4 in	(375 mm)
- Tread Diameter.....	12-1/2 in	(318 mm)
Weight .....	890 lbs	(404 kg)
Maximum Load Capacity.....	13,000 lbs	(5,896 kg)
Maximum Load Per Guide Wheel.....	6,500 lbs	(2,948 kg)

**SECTION 2 - OPERATION  
TABLE OF CONTENTS**

2.1 Preparing Vehicle For Operation . . . . . 2 - 3

2.2 Preparing Guide Wheel Equipment For Operation . . . . . 2 - 4

2.3 Misalignment Indicators . . . . . 2 - 4

2.4 Placing Vehicle On Track . . . . . 2 - 5

2.4.1 Lower Front Guide Wheels . . . . . 2 - 6

2.4.2 Steering Locks . . . . . 2 - 8

2.4.3 Rail Brakes . . . . . 2 - 9

2.4.4 Checking Vehicle Tire Clearance Above Rails . . . . . 2 - 9

2.5 Guide Wheel Load On Track . . . . . 2 - 10

2.5.1 Checking Front Guide Wheel Load On Track . . . . . 2 - 10

2.6 Propelling On Track . . . . . 2 - 11

2.7 Braking On Track . . . . . 2 - 12

2.7.1 Vehicles with Anti-Lock Brake Systems (ABS) . . . . . 2 - 12

2.8 Vehicles Equipped With Crane Or Aerial Lift Device . . . . . 2 - 13

2.9 Removing Vehicle From Track . . . . . 2 - 15

2.9.1 Raise Front Guide Wheels . . . . . 2 - 16

2.9.2 Steering Locks . . . . . 2 - 18

2.10 Highway Operation . . . . . 2 - 19

2.11 Towing Trailer / Equipment With Vehicle On Track . . . . . 2 - 20

2.12 Towing Trailer / Equipment With Vehicle On Road . . . . . 2 - 23

2.13 Towing Disabled Vehicle On Track . . . . . 2 - 26

2.14 Towing Disabled Vehicle On Road . . . . . 2 - 29



## 2.1 Preparing Vehicle for Operation

Be sure the vehicle is in operating condition by checking the following:

- a. Engine oil level.
- b. Radiator fluid level.
- c. Fuel tank level.
- d. Hydraulic reservoir oil level.
- e. Brakes work properly.
- f. Parking brake works properly.
- g. Head, brake and signal lights work properly.
- h. Tires properly inflated to the manufacturer's recommended maximum pressure printed on the sidewall of the tires, or the wheel manufacturer's recommended maximum pressure stamped on the wheel, whichever is lower.
- i. Vehicle wheels: Lug nuts / bolts tightened to the proper torque, inspect vehicle wheels, lug bolts and lug nuts for wear or damage. For vehicle wheel, lug bolt and lug nut inspection information refer to the USER'S GUIDE TO WHEELS AND RIMS produced by THE MAINTENANCE COUNCIL. To obtain this guide, contact:

THE MAINTENANCE COUNCIL  
AMERICAN TRUCKING ASSOCIATION  
2200 MILL ROAD  
ALEXANDRIA, VA. 22314  
Phone: (703) 838-1763

- j. Any other normal maintenance requirements.

## 2.2 Preparing Guide Wheel Equipment For Operation

Be sure the guide wheel equipment is in operating condition by checking the following:

- a. Air and hydraulic hoses and fittings for damage, wear or leaks.
- b. Overall for damaged or worn parts.
- c. Properly lubricated at the recommended operating mileage intervals.
- d. Brakes work properly.
- e. Hydraulic pressure properly adjusted.

2

## 2.3 Misalignment Indicators



■ **BEFORE OPERATING A VEHICLE WITH NEWLY INSTALLED GUIDE WHEEL EQUIPMENT ON TRACK, VERIFY THAT THE GUIDE WHEEL EQUIPMENT ALIGNMENT PROCEDURE HAS BEEN COMPLETED. CHECK AND CORRECT ALIGNMENT PROMPTLY IF MISALIGNMENT IS INDICATED. MISALIGNMENT OF GUIDE WHEEL EQUIPMENT COULD RESULT IN DERAILMENT OF VEHICLE AND SEVERE BODILY INJURY.**

The following conditions may indicate that minor adjustments to the guide wheel equipment alignment are necessary. If any of these conditions occur during operation, perform the Track Test, see Adjustment Section - Vehicle Track Test and/or complete the Alignment Procedure, see Adjustment - Guide Wheel Equipment Alignment Procedure.

1. Excessive flange or tread wear on any of the rail guide wheels.
2. Vehicle pulls noticeably to the left or the right during on track operation.
3. Vibration felt throughout the vehicle at various speeds during on track operation.

## 2.4 Placing Vehicle On Track



- PLACE VEHICLE AUTOMATIC TRANSMISSION IN "PARK" OR MANUAL TRANSMISSION IN "NEUTRAL". APPLY THE PARKING BRAKE.
- UNDERSTAND EQUIPMENT OPERATION AND BE AWARE OF ALL PINCH POINTS BEFORE OPERATING OR MAKING ADJUSTMENTS TO GUIDE WHEEL EQUIPMENT.
- BEFORE PROPELLING VEHICLE ON THE TRACK, MAKE SURE:
  - FRONT AND REAR GUIDE WHEELS ARE LOWERED AND LOCKED IN RAIL POSITION, AND SECURED WITH LOCK PIN.
  - ALL RAIL GUIDE WHEEL FLANGES ARE ENGAGED ON INSIDE OF RAIL.
  - VEHICLE FRONT TIRES ARE A MINIMUM OF 1-1/2" (38 mm) ABOVE THE RAIL.
  - STEERING WHEEL LOCK IS ENGAGED.
  - IF EQUIPPED, BRAKE CONTROL VALVE IS IN THE "ON" POSITION AND GUIDE WHEEL BRAKE EQUIPMENT IS FUNCTIONAL.

FAILURE TO HEED THESE WARNINGS COULD RESULT IN DERAILMENT OF VEHICLE AND SEVERE BODILY INJURY.



- WHEN USING VEHICLE MECHANICAL PTO HYDRAULIC PUMP TO LOWER/RAISE GUIDE WHEEL EQUIPMENT, DO NOT EXCEED HYDRAULIC SYSTEM FLOW OF 8 GPM (30 LPM) OR HYDRAULIC PRESSURE OF 2500 PSI (172 bar). EXCESSIVE FLOW AND / OR PRESSURE COULD DAMAGE HYDRAULIC SYSTEM COMPONENTS.
- OBSERVE AND FOLLOW ALL RAILROAD SAFETY RULES AND REGULATIONS.
- IF THE VEHICLE IS EQUIPPED WITH A STROBE LIGHT (BEACON) AND RAILROAD RULES AND REGULATIONS REQUIRE ITS USE, THE STROBE LIGHT (BEACON) MUST BE ILLUMINATED WHEN PLACING THE VEHICLE ON TRACK AND WHEN OPERATING THE VEHICLE ON TRACK.

FAILURE TO HEED THESE PRECAUTIONS COULD RESULT IN BODILY INJURY AND/OR PROPERTY DAMAGE.

## 2.4 Placing Vehicle On Track

1. Ensure that highway vehicles are not approaching the grade crossing while placing the vehicle on track. Flag the crossing per railroad rules and regulations to ensure safety.
2. At a road crossing, drive the vehicle about 25 feet (7.6 m) past the track. Back the vehicle onto the rails so that the rear vehicle wheels are centered on the rails. On vehicles with dual rear wheels, the inner dual wheels must be centered on the rails. It may be necessary to move the vehicle back and forth several times to get the wheels centered on the rail properly.
3. Place the vehicle automatic transmission in "PARK" or manual transmission in "NEUTRAL". Apply the parking brake.
4. Engage the mechanical PTO hydraulic pump or start the auxiliary hydraulic power source. If the vehicle is equipped with an auxiliary control valve, place the valve in the proper position to direct hydraulic oil flow to the guide wheel equipment.
5. Lower and lock the rear guide wheels first. The rear guide wheels should be lowered first so the front tires of the vehicle can be maneuvered to align the front guide wheels with the rails. See the Operator's Service And Parts Manual provided with the rear guide wheel unit for the procedure to lower the rear guide wheels.

### 2.4.1 Lowering Front Guide Wheels - See Figures 2-1 and 2-2

1. The front guide wheel unit may be equipped with manual lock pins or hydraulically actuated lock pins that secure the unit in the "highway" position.
2. Manual Lock Pins: Move Control Valve Handle (3) slightly to raise or lower the guide wheels to release any tension on the lock pins. Rotate lock pin (1) so the flat on the washer is in line with the securing angle. Pull the lock pin out and place it in its "rail" position storage hole (2). Make sure the pin is rotated so the washer is engaged behind the securing angle.
3. Hydraulic Locks: Move Control Valve Handle (3) slightly to raise or lower the guide wheels to release any tension on the lock pins. Push Control Valve Handle (4) down to disengage the locks. Visually check to make sure the locks are disengaged.
4. Pull control valve handle (3) up to lower the guide wheels. Make sure the guide wheels are fully lowered and the rail guide wheel flanges are engaged on the inside of the rails. Release the Control Valve Handle.
5. Make sure the vehicle front wheels are raised and suspended at least 1-1/2 inch (38 mm) above the top of the rails.
6. Disengage the mechanical PTO hydraulic pump or stop the auxiliary hydraulic power source. If the vehicle is equipped with an auxiliary control valve, place the valve in the proper position to shut off hydraulic oil flow to the guide wheel equipment.



## 2.4 Placing Vehicle On Track

### 2.4.1 Lowering Front Guide Wheels

*Note: Hydraulic control valve handles may operate differently from those described here due to the location, mounting and type of valve.*

FIGURE 2-1  
LOWERING FRONT GUIDE WHEELS - LOCK PINS

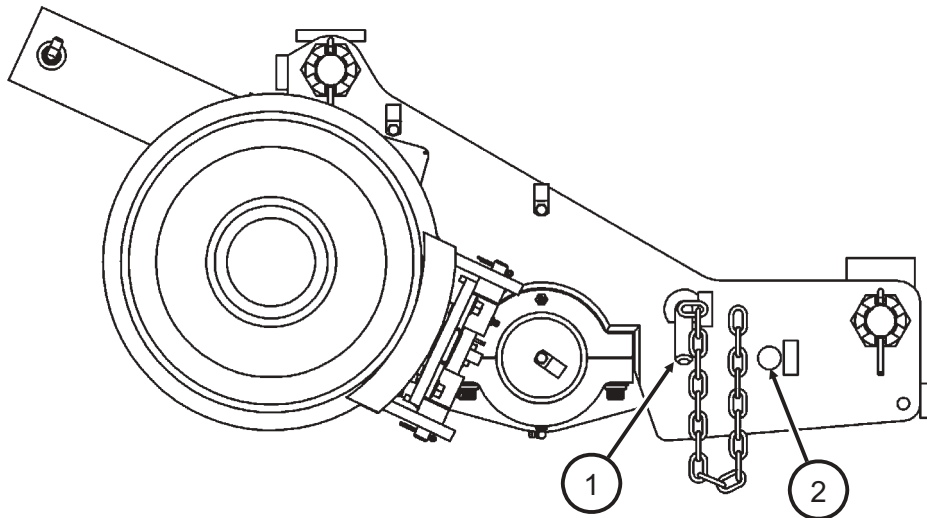
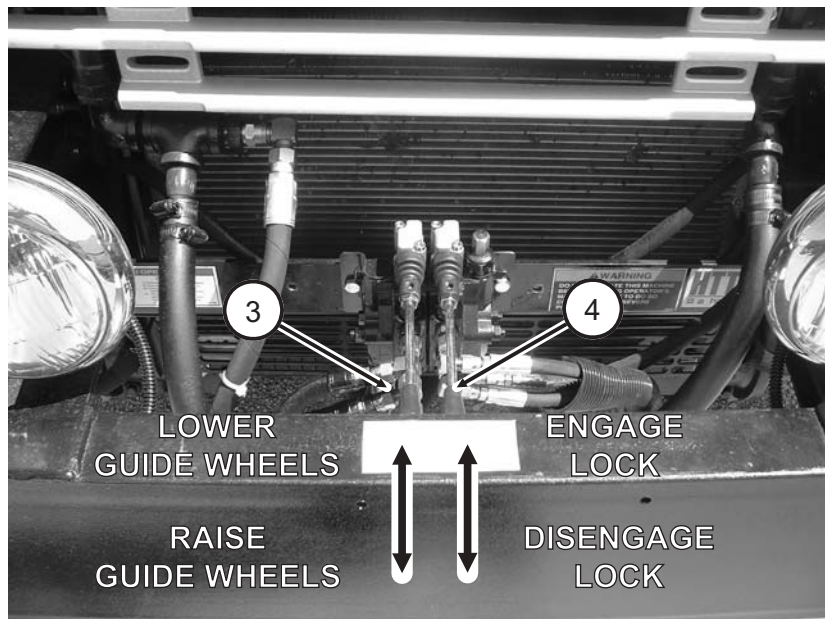

FIGURE 2-2  
LOWERING FRONT GUIDE WHEELS - HYDRAULIC LOCKS



## 2.4 Placing Vehicle On Track

### 2.4.2 Steering Locks - See Figures 2-3, 2-4, 2-5, 2-6, 2-7 and 2-8

Set the vehicle front wheels straight ahead and secure the steering wheel in that position by engaging the steering lock on the steering column. Steering locks may vary from vehicle to vehicle but will operate similarly.

2

*Note: Do not place your hands or any pressure on the steering wheel after the steering lock is engaged.*

FIGURE 2-3  
DEAD BOLT TYPE  
STEERING LOCK DISENGAGED

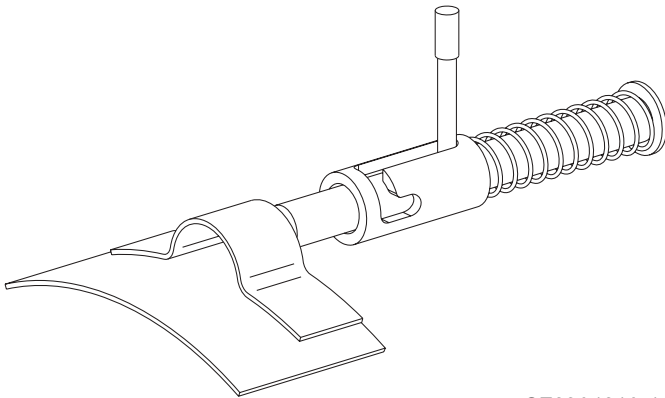

SE99A191A-1

FIGURE 2-4  
DEAD BOLT TYPE  
STEERING LOCK ENGAGED

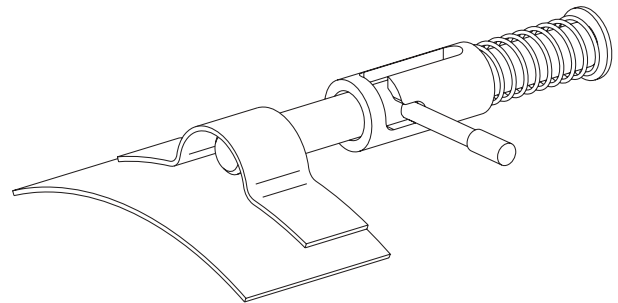

SE99A192A-1

FIGURE 2-5  
LOCK TAB TYPE  
STEERING LOCK DISENGAGED

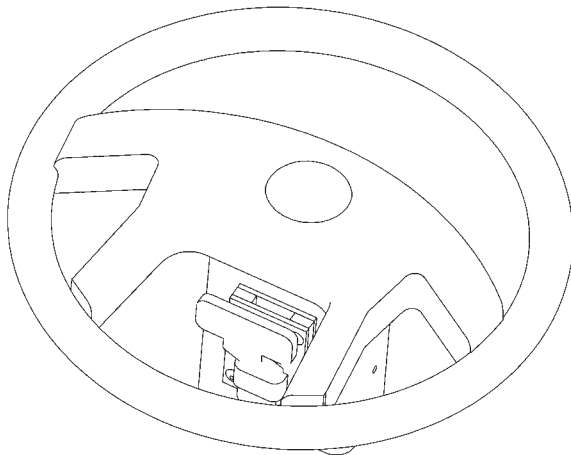
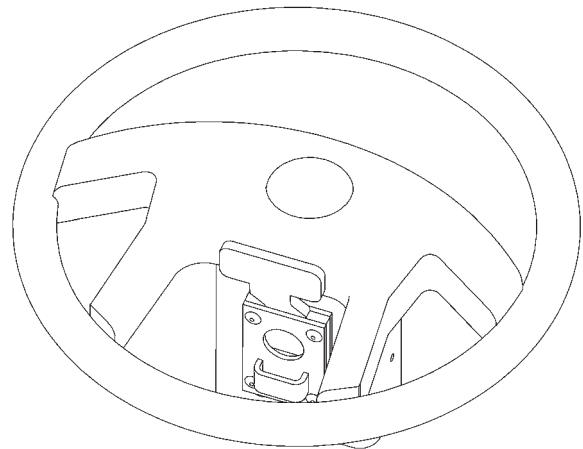

FIGURE 2-6  
LOCK TAB TYPE  
STEERING LOCK ENGAGED



## 2.4 Placing Vehicle On Track

### 2.4.2 Steering Locks

FIGURE 2-7  
VELCRO STEERING LOCK OFF

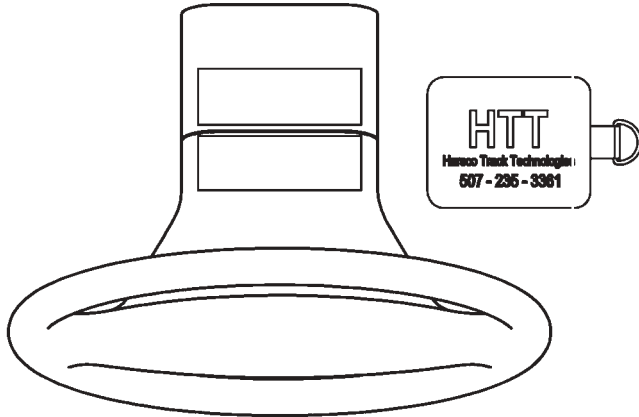
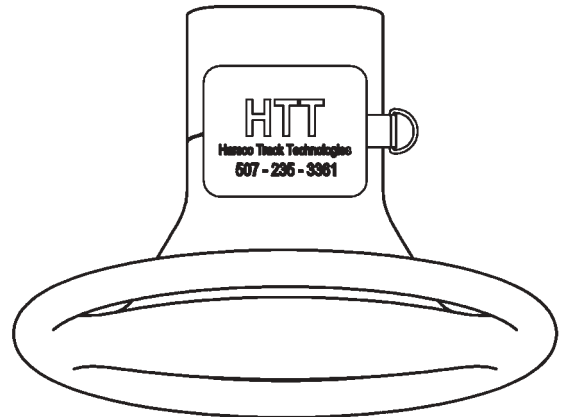

FIGURE 2-8  
VELCRO STEERING LOCK ON



### 2.4.3 Rail Brakes

If so equipped, move the Rail Wheel Brake Control Valve to the ON position to activate the guide wheel equipment brakes whenever the vehicle is on track. The vehicle brake pedal will actuate the vehicle brakes and the guide wheel equipment brakes simultaneously.

### 2.4.4 Check Vehicle Front Tire Clearance Above Rail

If the vehicle's front tire clearance above the rail is less than 1-1/2" (38 mm) the vehicle may be overloaded or the unit was not properly set-up when it was applied to the vehicle. Never operate the vehicle on track when the front tire clearance above the rail is less than 1-1/2" (38 mm).

## 2.5 Guide Wheel Load On Track



2

- **IMPROPER LOADING OF GUIDE WHEEL EQUIPMENT CAN CAUSE DERAILMENT OF VEHICLE.**
- **ALWAYS CHECK THE GUIDE WHEEL LOAD BEFORE OPERATING THE VEHICLE ON TRACK.**
- **NEVER OPERATE THE VEHICLE ON TRACK IF LOAD EXCEEDS THE MAXIMUM RATED LOAD OF THE FRONT AND/OR REAR GUIDE WHEEL UNITS. THE MAXIMUM LOAD ON THE FRONT GUIDE WHEEL UNIT IS 13,000 LBS (5896 kg) OR 6,500 LBS (2948 kg) MAXIMUM PER GUIDE WHEEL.**
- **NEVER OPERATE THE VEHICLE ON TRACK IF CLEARANCE BETWEEN VEHICLE FRONT TIRES AND RAIL IS LESS THAN 1-1/2" (38 mm).**

**FAILURE TO HEED THESE WARNINGS COULD RESULT IN DERAILMENT OF VEHICLE AND/OR SEVERE BODILY INJURY.**

Whenever the vehicle is loaded or additional load is added to the existing vehicle load on track, check the load on the front guide wheels. The maximum load on the front guide wheel unit is 13,000 lbs (5896 kg) or 6,500 lbs (2948 kg) maximum per guide wheel. Also, check the load on the rear guide wheel unit. See the Operator's Service And Parts Manual provided with the rear guide wheel unit for information on checking the load on the rear guide wheel unit.

### 2.5.1 Checking Front Guide Wheel Load

1. To check the load on the front guide wheels, the guide wheels must be located on a scale. Check the load on the guide wheel unit and on both guide wheels individually.
2. Apply the parking brake. Stop the engine.
3. The maximum load on the front guide wheel unit is 13,000 lbs (5896 kg) or 6,500 lbs (2948 kg) maximum per guide wheel. The guide wheel load must also be equal or within  $\pm 100$  lbs (45 kg) on the both the left and right ends of the guide wheel unit.

If the front guide wheel load does not exceed the maximum load capacity, the load on the front guide wheel is acceptable.

If the front guide wheel load does exceed the maximum load capacity, the load must be redistributed or some of the load removed. Never operate the vehicle on track if the load on the front guide wheel exceeds the maximum load capacity of 13,000 lbs (5896 kg) or 6,500 lbs (2948 kg) maximum per guide wheel.

4. **Rear Guide Wheel Load:** Whenever the vehicle is loaded, additional load is added to the existing vehicle load or the load on the vehicle is re-distributed, check the load on the rear guide wheels. See the Operator's Service And Parts Manual provided with the rear guide wheel unit for the procedure for checking the load on the rear guide wheel unit.

## 2.6 Propelling On Track



- **IMPROPER LOADING OF HY-RAIL® EQUIPPED VEHICLE CAN CAUSE DERAILMENT OF VEHICLE.**
- **ALWAYS CHECK GUIDE WHEEL LOAD BEFORE OPERATING THE VEHICLE ON TRACK.**
- **NEVER OPERATE VEHICLE ON TRACK IF LOAD EXCEEDS MAXIMUM RATED LOAD OF FRONT AND/OR REAR GUIDE WHEEL UNITS.**
- **NEVER OPERATE VEHICLE ON TRACK IF CLEARANCE BETWEEN VEHICLE FRONT TIRE AND RAIL IS LESS THAN 1-1/2" (38 mm).**

**FAILURE TO HEED THESE WARNINGS COULD RESULT IN DERAILMENT OF VEHICLE AND/OR SEVERE BODILY INJURY.**



- **BEFORE OR WHEN PROPELLING ON TRACK:**
  - **OBSERVE AND FOLLOW ALL RAILROAD SAFETY RULES AND REGULATIONS.**
  - **OPERATOR MUST LOOK IN ALL DIRECTIONS FOR PERSONS OR OBJECTS ON OR ADJACENT TO THE TRACK.**
  - **DO NOT ACCELERATE SUDDENLY. TRACTION IS REDUCED ON TRACK, SPINNING VEHICLE TIRES COULD DAMAGE THEM.**
  - **DO NOT EXCEED 25 MPH (40 km/h) WHEN OPERATING VEHICLE ON TRACK. RAILROAD RULES GOVERNING SPEEDS SHOULD BE OBSERVED AT ALL TIMES. REDUCE SPEED WHEN PROPELLING VEHICLE THROUGH SWITCHES, ROAD CROSSINGS, BRANCH LINES AND ANY SPECIAL TRACK WORKS. OPERATING VEHICLE AT UNSAFE SPEEDS COULD RESULT IN DERAILMENT OF THE VEHICLE.**
  - **STEERING LOCK MUST BE ENGAGED AT ALL TIMES WHEN OPERATING VEHICLE ON TRACK.**
  - **IF THE VEHICLE IS EQUIPPED WITH A STROBE LIGHT (BEACON) AND RAILROAD RULES AND REGULATIONS REQUIRE ITS USE, THE STROBE LIGHT (BEACON) MUST BE ILLUMINATED WHEN OPERATING THE VEHICLE ON TRACK.**

**FAILURE TO HEED THESE PRECAUTIONS COULD RESULT IN BODILY INJURY AND/OR PROPERTY DAMAGE.**

Vehicles equipped with the HR3000 Series C2 HY-RAIL® Guide Wheel Equipment use the vehicle propulsion system to propel on track. Do not accelerate suddenly. Traction is reduced on track. Spinning the vehicle tires could damage them.

## 2.7 Braking On Track



2

- **PERSONS WHO OPERATE THE VEHICLE MUST BE FAMILIAR WITH TRACK AND WEATHER CONDITIONS THAT MAY AFFECT STOPPING DISTANCE. BE ALERT TO THESE CONDITIONS AND ALLOW ADEQUATE STOPPING DISTANCE.**
- **BE PREPARED TO BRAKE AT ALL HIGHWAY CROSSINGS. THIS VEHICLE MAY NOT OPERATE TRACK SIGNAL CIRCUITS, AND ONCOMING VEHICLES OR PEDESTRIANS MAY NOT YIELD THE RIGHT OF WAY.**
- **IF EQUIPPED, RAIL WHEEL BRAKE CONTROL VALVE MUST BE IN THE "ON" POSITION WHENEVER VEHICLE IS ON TRACK.**

**FAILURE TO HEED THESE PRECAUTIONS COULD RESULT IN BODILY INJURY AND/OR PROPERTY DAMAGE.**

The HR3000 Series C2 HY-RAIL® Guide Wheel Equipment may be equipped with brakes. If the guide wheel unit is equipped with brakes, the vehicle uses a combination of the front guide wheel unit brakes and the vehicle's rear axle brake system for braking on track. The front guide wheel unit brakes will apply simultaneously when the vehicle brakes are applied. Stopping distance is greater on track than on typical road surfaces. Apply the brakes gradually to avoid sliding the vehicle tires and rail guide wheels.

### 2.7.1 Vehicles with Anti-Lock Brake Systems (ABS)

While operating on track, the ABS becomes ineffective in brake application at lower speeds. If the ABS is active and the truck is moving on rail with front wheels elevated, an indicator on the dash may come on. Since the front wheels are not rotating, the motion sensors may transmit a fault indication to the ABS Electronic Control Unit (ECU), which signals the dash indicator to illuminate. This will not affect rear truck braking or rail wheel braking.

When the vehicle is returned to highway operation, the ABS fault must be cleared or the ABS will not function correctly and the indicator will remain illuminated. The fault can be cleared by stopping and restarting the vehicle's engine. When the engine is restarted, the ABS ECU will run a diagnostic check and the fault should be cleared. If the ABS fault does not clear, contact the brake system manufacture for assistance.

## 2.8 Vehicles Equipped With Crane Or Aerial Lift Device



- **WHEN OPERATING CRANE, AERIAL LIFT DEVICE, ETC., WHILE THE VEHICLE'S GUIDE WHEELS ARE ON THE RAILS, DO NOT OVERLOAD THE GUIDE WHEEL EQUIPMENT OR EXCEED THE CAPACITY OF ANY OF THE EQUIPMENT BEING USED.**
- **THE UNIT SHOULD BE EQUIPPED WITH OUTRIGGERS TO HELP PREVENT ACCIDENTS AND THE POSSIBILITY OF DAMAGE TO THE GUIDE WHEEL EQUIPMENT. WHEN USING THE EQUIPMENT TO TRANSFER ANY LOAD, SET THE OUTRIGGERS ON A STABLE BASE TO PREVENT SETTLING OF THE OUTRIGGERS AND SHIFTING OF THE VEHICLE.**
- **IF OPERATING CONDITIONS REQUIRE LIFTING A LOAD WITH THE CRANE WHILE ON RAIL, BUT WITHOUT THE OUTRIGGERS BEING USED, THE LOAD APPLIED BY LIFTING WITH THE CRANE MUST NOT OVERLOAD ANY COMPONENT OF THE GUIDE WHEEL EQUIPMENT.**
- **CAREFULLY READ THE CRANE OR AERIAL LIFT DEVICE OPERATOR'S MANUAL FOR THE SAFE USE AND EFFICIENT OPERATION OF THE EQUIPMENT.**

**FAILURE TO HEED THESE WARNINGS COULD CAUSE DERAILMENT OF THE VEHICLE RESULTING IN SEVERE BODILY INJURY AND/OR DEATH.**

1. When operating a crane, aerial lift device, etc., while the vehicle's guide wheels are on the rails, do not overload the guide wheel equipment or exceed the capacity of any of the equipment being used.
2. The crane, aerial lift device, etc. should be equipped with outriggers to help prevent accidents and the possibility of damage to the guide wheel equipment. When using the crane, aerial lift device, etc. to transfer any load, set the outriggers on a stable base to prevent settling of the outriggers and shifting of the vehicle. Carefully read the crane or aerial lift equipment operator's manual for the safe use and efficient operation of the equipment.
3. If operating conditions require lifting a load with the crane while on rail, but without the outriggers being used, the load applied by lifting with the crane must not overload any component of the guide wheel equipment.





## 2.9 Removing Vehicle From Track



- PLACE VEHICLE AUTOMATIC TRANSMISSION IN "PARK" OR MANUAL TRANSMISSION IN "NEUTRAL". APPLY THE PARKING BRAKE.
- UNDERSTAND EQUIPMENT OPERATION AND BE AWARE OF ALL PINCH POINTS BEFORE OPERATING OR MAKING ADJUSTMENTS TO GUIDE WHEEL EQUIPMENT.
- BEFORE PROPELLING VEHICLE OFF TRACK, MAKE SURE:
  - FRONT AND REAR GUIDE WHEELS ARE RAISED, LOCKED IN THE HIGHWAY POSITION, AND SECURED WITH THE LOCK PINS.
  - STEERING WHEEL LOCK IS DISENGAGED.

FAILURE TO HEED THESE WARNINGS COULD RESULT IN SEVERE BODILY INJURY.



- WHEN USING VEHICLE MECHANICAL PTO HYDRAULIC PUMP TO LOWER/RAISE GUIDE WHEEL EQUIPMENT, DO NOT EXCEED HYDRAULIC SYSTEM FLOW OF 8 GPM (30 LPM) OR HYDRAULIC PRESSURE OF 2500 PSI (172 bar). EXCESSIVE FLOW AND / OR PRESSURE COULD DAMAGE HYDRAULIC SYSTEM COMPONENTS.
- OBSERVE AND FOLLOW ALL RAILROAD SAFETY RULES AND REGULATIONS.
- IF THE VEHICLE IS EQUIPPED WITH A STROBE LIGHT (BEACON) AND RAILROAD RULES AND REGULATIONS REQUIRE ITS USE, THE STROBE LIGHT (BEACON) MUST BE ILLUMINATED WHEN OPERATING AND REMOVING THE VEHICLE FROM TRACK.

FAILURE TO HEED THESE PRECAUTIONS COULD RESULT IN BODILY INJURY AND/OR PROPERTY DAMAGE.

## 2.9 Removing Vehicle From Track

1. Ensure that highway vehicles are not approaching the grade crossing while placing the vehicle on track. Flag the crossing per railroad rules and regulations to ensure safety.
2. Approach the crossing and stop with the vehicle front wheels on the crossing.
3. Place the vehicle automatic transmission in "PARK" or manual transmission in "NEUTRAL". Apply the parking brake.
4. If so equipped, move the Rail Wheel Brake Control Valve to the OFF position, whenever the vehicle is removed from the track for highway use.
5. Engage the mechanical PTO hydraulic pump or start the auxiliary hydraulic power source. If the vehicle is equipped with an auxiliary control valve, place the valve in the proper position to direct hydraulic oil flow to the guide wheel equipment.

### 2.9.1 Raising Front Guide Wheels - See Figures 2-9 and 2-10

1. The front guide wheel unit may be equipped with manual lock pins or hydraulically actuated lock pins that secure the unit in the "highway" position.
2. Push control valve handle (3) down to raise the guide wheels. Make sure the guide wheels are fully raised. Release the Control Valve Handle.
3. Manual Lock Pins: Rotate lock pin (1) so the flat on the washer is in line with the securing angle. Pull the lock pin out of its "rail" position storage hole (2). Install the lock pin the the "highway" position hole. Make sure the pin is rotated so the washer is engaged behind the securing angle. If the lock pins (1) do not easily insert, move Control Valve Handle (3) slightly to raise or lower the guide wheels to allow the lock pins to insert.
4. Hydraulic Locks: Pull Control Valve Handle (4) up to engage the locks. If the locks do not readily engage, move Control Valve Handle (3) slightly to raise or lower the guide wheels to allow the lock pins to engage. Visually check to make sure the locks are engaged.
5. Raise and lock the rear guide wheels in the "highway" position. See the Operator's Service And Parts Manual provided with the rear guide wheel unit for the procedure to raise the rear guide wheels.
6. Disengage the mechanical PTO hydraulic pump or stop the auxiliary hydraulic power source. If the vehicle is equipped with an auxiliary control valve, place the valve in the proper position to shut off hydraulic oil flow to the guide wheel equipment.

*Note: Hydraulic control valve handles may operate differently from those described here due to location, mounting and type of valve.*

## 2.9 Removing Vehicle From Track

### 2.9.1 Raising Front Guide Wheels

FIGURE 2-9  
LOWERING FRONT GUIDE WHEELS - LOCK PINS

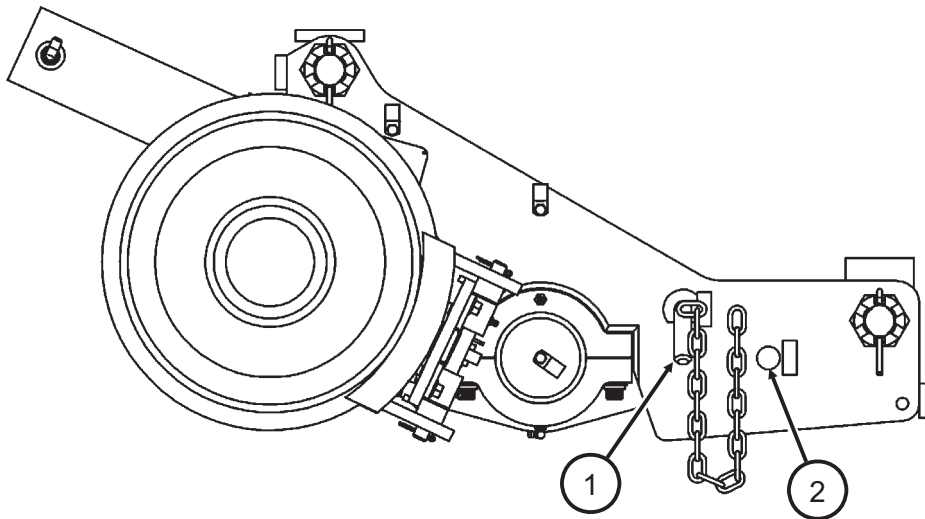

2

FIGURE 2-10  
LOWERING FRONT GUIDE WHEELS - HYDRAULIC LOCKS

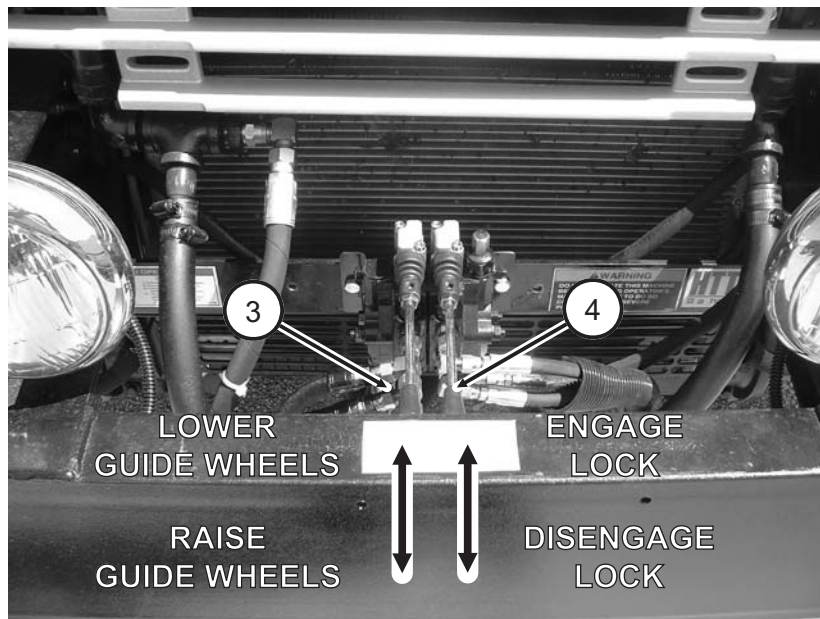

## 2.9 Removing Vehicle From Track

### 2.9.2 Steering Locks - See Figures 2-11, 2-12, 2-13, 2-14, 2-15 and 2-16

- 1 Disengage the vehicle steering lock located on the steering column. Steering locks may vary from vehicle to vehicle but will operate similarly.

2

FIGURE 2-11  
DEAD BOLT TYPE  
STEERING LOCK DISENGAGED

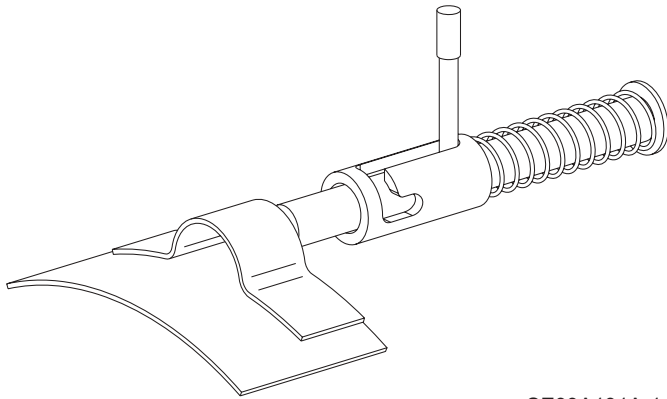

SE99A191A-1

FIGURE 2-12  
DEAD BOLT TYPE  
STEERING LOCK ENGAGED

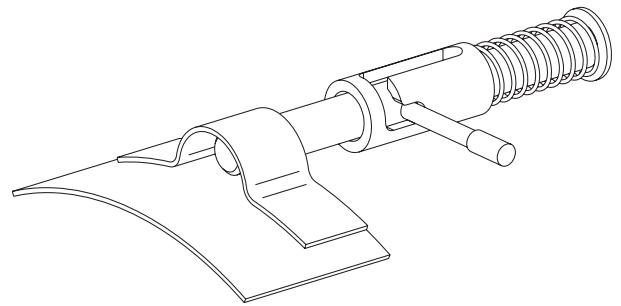

SE99A192A-1

FIGURE 2-13  
LOCK TAB TYPE  
STEERING LOCK DISENGAGED

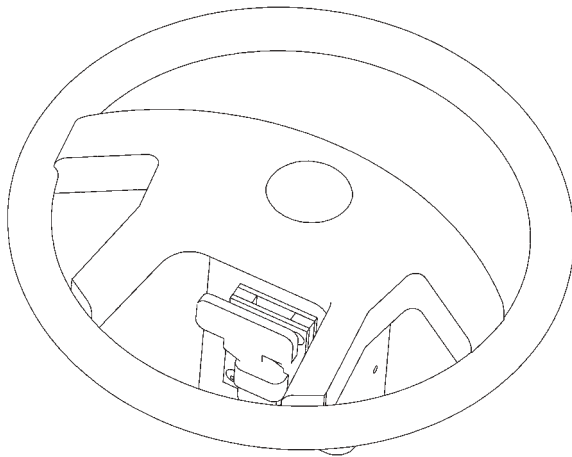
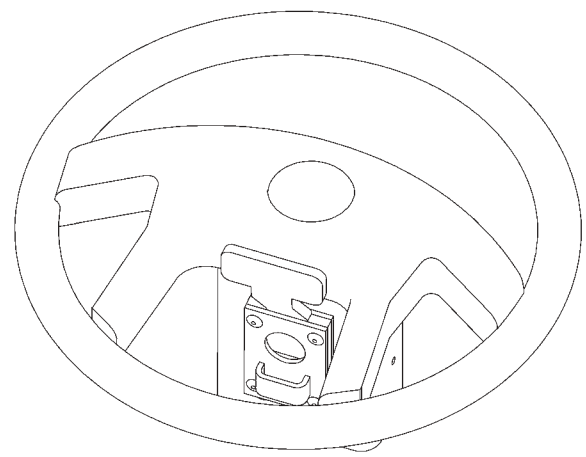

FIGURE 2-14  
LOCK TAB TYPE  
STEERING LOCK ENGAGED



## 2.9 Removing Vehicle From Track

### 2.9.2 Steering Locks

FIGURE 2-15  
VELCRO STEERING LOCK OFF

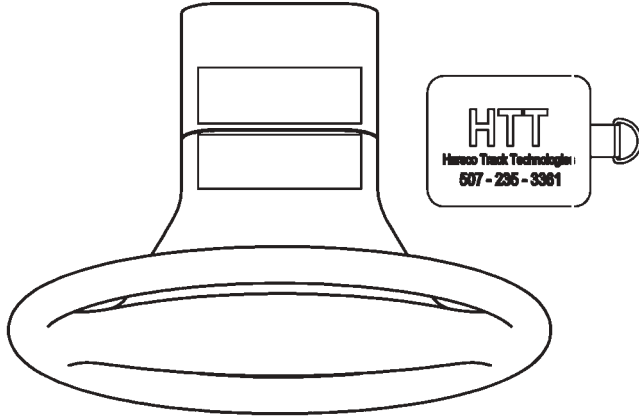
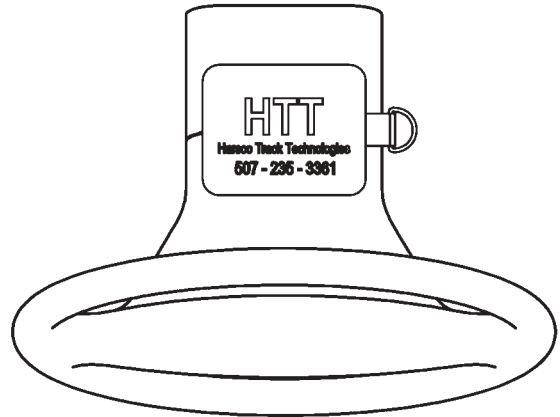

FIGURE 2-16  
VELCRO STEERING LOCK ON



## 2.10 Highway Operation



- THIS MULTIPURPOSE VEHICLE HAS SPECIAL DESIGN AND EQUIPMENT FEATURES FOR OFF-ROAD USE. IT HANDLES DIFFERENTLY FROM AN ORDINARY PASSENGER CAR IN DRIVING CONDITIONS WHICH MAY OCCUR ON STREETS, HIGHWAYS AND OFF-ROAD. WEIGHT AND LOCATION OF AVAILABLE PAYLOAD MAY ALSO AFFECT THE HANDLING OF THIS VEHICLE. DRIVE WITH CARE AND WEAR SAFETY BELTS AT ALL TIMES. READ VEHICLE OWNER'S MANUAL FOR ADDITIONAL PRECAUTIONS.

## 2.11 Towing Trailer / Equipment With Vehicle On Track



2

- VEHICLE USED FOR TOWING MUST BE RATED BY VEHICLE MANUFACTURER FOR WEIGHT OF TRAILER / EQUIPMENT TO BE TOWED. DO NOT EXCEED VEHICLE MANUFACTURER'S MAXIMUM RATED TOWING CAPACITY.
- TOWING VEHICLE MUST WEIGH AS MUCH OR MORE THAN TRAILER / EQUIPMENT BEING TOWED.
- VEHICLE USED FOR TOWING MUST HAVE AN ADEQUATE BRAKE SYSTEM TO SAFELY DECELERATE AND STOP TOWING VEHICLE AND TRAILER / EQUIPMENT BEING TOWED.
- TOWING TRAILER / EQUIPMENT LENGTHENS STOPPING DISTANCES. ALLOW ADEQUATE DISTANCE FOR STOPPING. ANTICIPATE STOPS SO YOU CAN BRAKE GRADUALLY.
- STOPPING DISTANCE IS GREATER ON TRACK THAN ON TYPICAL ROAD SURFACES. APPLY BRAKES GRADUALLY TO AVOID SLIDING VEHICLE TIRES AND GUIDE WHEELS.
- TOW TRAILER / EQUIPMENT AT A REASONABLE SPEED (20 MPH MAXIMUM) TAKING INTO ACCOUNT TRACK CONDITIONS, TRACK GRADE, WEATHER, VISIBILITY AND STOPPING DISTANCE TO ASSURE SAFE OPERATION. RAILROAD RULES GOVERNING SPEEDS AND RIGHT OF WAY SHOULD BE OBSERVED AT ALL TIMES.
- TRAILER / EQUIPMENT BEING TOWED MUST BE IN A SAFE, USABLE CONDITION TO BE TOWED.
- MAKE SURE THAT VEHICLE'S:
  - FRONT AND REAR GUIDE WHEEL ARE LOWERED AND LOCKED IN THE RAIL POSITION.
  - ALL GUIDE WHEEL FLANGES ARE ENGAGED ON INSIDE OF RAILS.
  - FRONT TIRES ARE A MINIMUM OF 1-1/2" (38 mm) ABOVE RAIL.
  - VEHICLE STEERING WHEEL LOCK ENGAGED WITH FRONT WHEELS STRAIGHT AHEAD.

**FAILURE TO HEED THESE WARNINGS COULD RESULT IN SEVERE BODILY INJURY.**

## 2.11 Towing Trailer / Equipment With Vehicle On Track



- CAREFULLY AND THOROUGHLY PREPARE VEHICLE FOR TOWING, MAKING SURE TO USE THE RIGHT TOWING EQUIPMENT AND TO ATTACH IT PROPERLY.
- TOWING EQUIPMENT (HITCHES, TOW BARS, ETC.) MUST BE ATTACHED TO VEHICLE FRAME. DO NOT MOUNT OR ATTACH TOWING EQUIPMENT TO VEHICLE'S GUIDE WHEEL EQUIPMENT.
- TOWING EQUIPMENT (HITCHES, TOW BARS, ETC.) MUST HAVE A RATED TOWING CAPACITY EQUAL TO OR GREATER THAN WEIGHT OF TRAILER / EQUIPMENT BEING TOWED.
- USE A RIGID TYPE TOW BAR WITH SAFETY LOCKING COUPLERS. DO NOT USE CHAIN, WIRE ROPE ETC.
- OBSERVE AND FOLLOW ALL RAILROAD SAFETY RULES AND REGULATIONS.
- DO NOT ACCELERATE SUDDENLY. TRACTION IS REDUCED ON RAIL, SPINNING VEHICLE TIRES COULD DAMAGE THEM.
- ALWAYS CHOCK TRAILER WHEELS BEFORE UNHOOKING TRAILER FROM TOWING VEHICLE.

FAILURE TO HEED THESE PRECAUTIONS COULD RESULT IN BODILY INJURY AND/OR PROPERTY DAMAGE.

## 2.11 Towing Trailer / Equipment With Vehicle On Track

1. See your vehicle's operators manual for towing information.
2. Use the vehicle manufacturer's recommendations to determine the maximum weight the towing vehicle can tow. Do not exceed vehicle manufacturer's maximum rated towing capacity.
3. The towing vehicle must have an adequate brake system to safely decelerate and stop the towing vehicle and the trailer / equipment being towed. The towing vehicle must weigh as much or more than the trailer / equipment being towed.
4. Make sure that the vehicle's:
  - a. Front and rear guide wheels are lowered and locked in the rail position.
  - b. All guide wheel flanges are engaged on the inside of the rails.
  - c. Front tires are a minimum of 1-1/2" (38 mm) above the rail.
  - d. Vehicle front wheels are set straight ahead and the steering wheel lock is engaged on the steering column.
5. Make sure the towing vehicle and the trailer / equipment are in good working condition (tires, brakes, lights, etc.) and that current maintenance has been performed on the vehicle and trailer / equipment.
6. The towing equipment (hitches, tow bars, etc.) on the towing vehicle must have a rating equal to or greater than the weight of the trailer / equipment being towed.
7. The towing equipment (hitches, tow bars, etc.) must be attached to the towing vehicle frame. Do not mount or attach the towing equipment to the vehicle's guide wheel equipment.
8. Observe and follow all railroad safety rules and regulations.
9. Do not accelerate suddenly. Traction is reduced on rail. Spinning the vehicle tires could damage them.
10. Stopping distance is greater on rail than on typical road surfaces. Apply the vehicle brakes gradually to avoid sliding the vehicle tires and the guide wheels. Towing trailer / equipment lengthens stopping distances. Allow adequate distance for stopping. Anticipate stops so that you can brake gradually.
11. Tow the trailer / equipment on the track at a reasonable speed (20 MPH maximum) taking into account track conditions, track grade, weather, visibility and stopping distance to assure safe operation. Railroad rules and regulations governing speed limits and right of way should be observed at all times.
12. Always chock the trailer wheels before unhooking the trailer from the towing vehicle.



## 2.12 Towing Trailer / Equipment With Vehicle On Road



- VEHICLE USED FOR TOWING MUST BE RATED BY VEHICLE MANUFACTURER FOR WEIGHT OF TRAILER / EQUIPMENT TO BE TOWED. DO NOT EXCEED VEHICLE MANUFACTURER'S MAXIMUM RATED TOWING CAPACITY.
- VEHICLE USED FOR TOWING MUST HAVE AN ADEQUATE BRAKE SYSTEM TO SAFELY DECELERATE AND STOP TOWING VEHICLE AND TRAILER / EQUIPMENT BEING TOWED.
- TOWING TRAILER / EQUIPMENT LENGTHENS STOPPING DISTANCES. ALLOW ADEQUATE DISTANCE FOR STOPPING. ANTICIPATE STOPS SO YOU CAN BRAKE GRADUALLY.
- TOW TRAILER / EQUIPMENT AT A REASONABLE SPEED TAKING INTO ACCOUNT ROAD CONDITIONS, ROAD GRADE, WEATHER, VISIBILITY AND STOPPING DISTANCE TO ASSURE SAFE OPERATION. POSTED SPEED LIMITS SHOULD BE OBSERVED AT ALL TIMES.
- TRAILER / EQUIPMENT BEING TOWED MUST BE IN A SAFE, USABLE CONDITION TO BE TOWED.
- MAKE SURE THAT VEHICLE'S:
  - FRONT AND REAR GUIDE WHEELS ARE RAISED AND LOCKED IN HIGHWAY POSITION.
  - VEHICLE STEERING WHEEL LOCK DISENGAGED.

FAILURE TO HEED THESE WARNINGS COULD RESULT IN SEVERE BODILY INJURY.

## 2.12 Towing Trailer / Equipment With Vehicle On Road



2

- THIS MULTIPURPOSE VEHICLE HAS SPECIAL DESIGN AND EQUIPMENT FEATURES FOR OFF-ROAD USE. IT HANDLES DIFFERENTLY FROM AN ORDINARY PASSENGER CAR IN DRIVING CONDITIONS WHICH MAY OCCUR ON STREETS, HIGHWAYS AND OFF-ROAD. WEIGHT AND LOCATION OF AVAILABLE PAYLOAD MAY ALSO AFFECT THE HANDLING OF THIS VEHICLE. DRIVE WITH CARE AND WEAR SAFETY BELTS AT ALL TIMES. READ VEHICLE OWNER'S MANUAL FOR ADDITIONAL PRECAUTIONS.
- OBSERVE AND FOLLOW ALL FEDERAL, STATE AND LOCAL DRIVING RULES AND REGULATIONS.
- STATE LAWS MAY REQUIRE TOWING VEHICLE AND TRAILER / EQUIPMENT BEING TOWED TO BE EQUIPPED WITH SPECIAL SAFETY EQUIPMENT (MIRRORS ON BOTH SIDES OF TOWING VEHICLE, TRAILER BRAKES, TRAILER LIGHTS, ETC.).
- CAREFULLY AND THOROUGHLY PREPARE YOUR VEHICLE FOR TOWING, MAKING SURE TO USE THE RIGHT TOWING EQUIPMENT AND TO ATTACH IT PROPERLY.
- TOWING EQUIPMENT (HITCHES, TOW BARS, ETC.) MUST BE ATTACHED TO VEHICLE FRAME. DO NOT MOUNT OR ATTACH TOWING EQUIPMENT TO VEHICLE'S GUIDE WHEEL EQUIPMENT.
- TOWING EQUIPMENT (HITCH, TOW BAR, ETC.) MUST HAVE A RATED TOWING CAPACITY EQUAL TO OR GREATER THAN WEIGHT OF TRAILER / EQUIPMENT BEING TOWED.
- ALWAYS CHOCK TRAILER WHEELS BEFORE UNHOOKING TRAILER FROM TOWING VEHICLE.

**FAILURE TO HEED THESE PRECAUTIONS COULD RESULT IN BODILY INJURY AND/OR PROPERTY DAMAGE.**

## 2.12 Towing Trailer / Equipment With Vehicle On Road

1. See your vehicle's operators manual for towing information.
2. Use the vehicle manufacturer's recommendations to determine the maximum weight the towing vehicle can tow. Do not exceed vehicle manufacturer's maximum rated towing capacity.
3. The towing vehicle must have an adequate brake system to safely decelerate and stop the towing vehicle and the trailer / equipment being towed. Towing trailer / equipment lengthens stopping distances. Allow adequate distance for stopping. Anticipate stops so that you can brake gradually.
4. Make sure that the vehicle's:
  - a. Front and rear guide wheels are raised and locked in the highway position.
  - b. Vehicle steering wheel lock is disengaged on the steering column.
5. Make sure the towing vehicle and the trailer / equipment are in good working condition (tires, brakes, lights, etc.) and that current maintenance has been performed on the vehicle and trailer / equipment.
6. The towing equipment (hitches, tow bars, etc.) on the towing vehicle must have a rating equal to or greater than the weight of the trailer / equipment being towed.
7. The towing equipment (hitches, tow bars, etc.) must be attached to the towing vehicle frame. Do not mount or attach the towing equipment to the vehicle's guide wheel equipment.
8. Observe and follow all federal, state and local driving rules, regulations and laws.
9. State laws may require the towing vehicle and/or the trailer / equipment being towed to be equipped with special safety equipment (mirrors on both sides of the towing vehicle, trailer brakes, trailer lights, etc.).
10. Tow the trailer / equipment on the road at a reasonable speed taking into account road conditions, road grade, weather, visibility and stopping distance to assure safe operation. Always observe posted speed limits.
11. Always chock the trailer wheels before unhooking the trailer from the towing vehicle.

### 2.13 Towing Disabled Vehicle On Track



2

- TOWING VEHICLE / MACHINE MUST WEIGH AS MUCH OR MORE THAN DISABLED VEHICLE BEING TOWED.
- VEHICLE / MACHINE USED FOR TOWING MUST HAVE AN ADEQUATE BRAKE SYSTEM TO SAFELY DECELERATE AND STOP TOWING VEHICLE / MACHINE AND DISABLED VEHICLE BEING TOWED.
- TOWING DISABLED VEHICLE LENGTHENS STOPPING DISTANCES. ALLOW ADEQUATE DISTANCE FOR STOPPING. ANTICIPATE STOPS SO YOU CAN BRAKE GRADUALLY.
- TOW DISABLED VEHICLE AT A REASONABLE SPEED (10 MPH MAXIMUM) TAKING INTO ACCOUNT TRACK CONDITIONS, TRACK GRADE, WEATHER, VISIBILITY AND STOPPING DISTANCE TO ASSURE SAFE OPERATION. RAILROAD RULES GOVERNING SPEED LIMITS AND RIGHT OF WAY SHOULD BE OBSERVED AT ALL TIMES.
- STOPPING DISTANCE IS GREATER ON TRACK THAN ON TYPICAL ROAD SURFACES. APPLY BRAKES GRADUALLY TO AVOID SLIDING TOWING VEHICLE / MACHINE WHEELS.
- MAKE SURE THAT DISABLED VEHICLE'S:
  - FRONT AND REAR GUIDE WHEELS ARE LOWERED AND LOCKED IN RAIL POSITION.
  - ALL GUIDE WHEEL FLANGES ARE ENGAGED ON INSIDE OF RAILS.
  - FRONT TIRES ARE A MINIMUM OF 1-1/2" (38 mm) ABOVE RAIL.
  - VEHICLE STEERING WHEEL LOCK ENGAGED WITH FRONT WHEELS STRAIGHT AHEAD.

**FAILURE TO HEED THESE WARNINGS COULD RESULT IN SEVERE BODILY INJURY.**

### 2.13 Towing Disabled Vehicle On Track



- TOW BAR MUST BE ATTACHED TO DISABLED VEHICLE'S FRAME. DO NOT MOUNT OR ATTACH TOW BAR TO DISABLED VEHICLE'S GUIDE WHEEL EQUIPMENT.
- TOW BAR MUST HAVE A RATED TOWING CAPACITY EQUAL TO OR GREATER THAN WEIGHT OF DISABLED VEHICLE BEING TOWED.
- USE A RIGID TYPE TOW BAR WITH SAFETY LOCKING COUPLERS. DO NOT USE CHAIN, WIRE ROPE ETC.
- OBSERVE AND FOLLOW ALL RAILROAD SAFETY RULES AND REGULATIONS.
- DO NOT ACCELERATE SUDDENLY. TRACTION IS REDUCED ON RAIL, SPINNING TOWING VEHICLE / MACHINE WHEELS COULD DAMAGE THEM.
- TOW DISABLED VEHICLE TO NEAREST ROAD CROSSING AND REMOVE FROM TRACK.

FAILURE TO HEED THESE PRECAUTIONS COULD RESULT IN BODILY INJURY AND/OR PROPERTY DAMAGE.

### 2.13 Towing Disabled Vehicle On Track

1. See your vehicle's operators manual for towing information.
2. The towing vehicle / machine must have an adequate brake system to safely decelerate and stop the towing vehicle / machine and the disabled vehicle being towed. The towing vehicle / machine must weigh as much or more than the disabled vehicle towed.
3. Make sure that the disabled vehicle's:
  - a. Front and rear guide wheels are lowered and locked in the rail position.
  - b. All guide wheel flanges are engaged on the inside of the rails.
  - c. Front tires are a minimum of 1-1/2" (38 mm) above the rail.
  - d. Vehicle front wheels are set straight ahead and the steering wheel lock is engaged on the steering column.
4. Make sure the towing vehicle / machine is in good working condition (tires, brakes, lights, etc.) and that current maintenance has been performed on the vehicle / machine.
5. The towing equipment (hitches, tow bars, etc.) on the towing vehicle / machine must have a rating equal to or greater than the weight of the disabled vehicle being towed.
6. The tow bar must be mounted or attached to the disabled vehicle's frame. Do not mount or attach the tow bar to the disabled vehicle's guide wheel equipment. Use a rigid type tow bar with safety locking couplers.
7. Observe and follow all railroad safety rules and regulations.
8. Do not accelerate suddenly. Traction is reduced on rail. Spinning the towing vehicle tires / machine wheels could damage them.
9. Stopping distance is greater on rail than on typical road surfaces. Apply the towing vehicle / machine brakes gradually to avoid sliding the vehicle tires / machine wheels. Towing disabled vehicle lengthens stopping distances. Allow adequate distance for stopping. Anticipate stops so that you can brake gradually.
10. Tow the disabled vehicle on the track at a reasonable speed (10 MPH maximum) taking into account track conditions, track grade, weather, visibility and stopping distance to assure safe operation. Railroad rules and regulations governing speed limits and right of way should be observed at all times.
11. Tow the disabled vehicle to the nearest road crossing and remove the vehicle from the track.

## 2.14 Towing Disabled Vehicle On Road



- TOW DISABLED VEHICLE PER VEHICLE MANUFACTURER'S TOWING SPECIFICATIONS LISTED IN YOUR VEHICLE'S OPERATORS MANUAL.
- VEHICLE USED FOR TOWING MUST HAVE AN ADEQUATE BRAKE SYSTEM TO SAFELY DECELERATE AND STOP TOWING VEHICLE AND DISABLED VEHICLE BEING TOWED.
- TOW DISABLED VEHICLE AT A REASONABLE SPEED TAKING INTO ACCOUNT ROAD CONDITIONS, ROAD GRADE, WEATHER, VISIBILITY AND STOPPING DISTANCE TO ASSURE SAFE OPERATION. POSTED SPEED LIMITS SHOULD BE OBSERVED AT ALL TIMES.
- MAKE SURE DISABLED VEHICLE'S:
  - FRONT AND REAR GUIDE WHEELS ARE RAISED AND LOCKED IN HIGHWAY POSITION.
  - VEHICLE STEERING WHEEL LOCK DISENGAGED.

FAILURE TO HEED THESE WARNINGS COULD RESULT IN SEVERE BODILY INJURY.



- TOWING EQUIPMENT (TOW TRUCK, TOW BARS, ETC.) MUST BE ATTACHED TO DISABLED VEHICLE'S FRAME. DO NOT MOUNT OR ATTACH TOWING EQUIPMENT TO DISABLED VEHICLE'S GUIDE WHEEL EQUIPMENT.
- TOWING EQUIPMENT (TOW TRUCK, TOW BARS, ETC.) MUST HAVE A RATED TOWING CAPACITY EQUAL TO OR GREATER THAN WEIGHT OF DISABLED VEHICLE BEING TOWED.
- OBSERVE AND FOLLOW ALL FEDERAL, STATE AND LOCAL DRIVING RULES AND REGULATIONS.
- STATE LAWS MAY REQUIRE TOWING VEHICLE AND DISABLED VEHICLE TO BE EQUIPPED WITH SPECIAL SAFETY EQUIPMENT (LIGHTS, ETC.).

FAILURE TO HEED THESE PRECAUTIONS COULD RESULT IN BODILY INJURY AND/OR PROPERTY DAMAGE.

## 2.14 Towing Disabled Vehicle On Road

1. See your vehicle's operators manual for towing information.
2. The towing vehicle must have an adequate brake system to safely decelerate and stop the towing vehicle and the disabled vehicle being towed.
2. Make sure that the disabled vehicle's:
  - a. Front and rear guide wheels are raised and locked in the highway position.
  - b. Vehicle steering wheel lock is disengaged on the steering column.
4. Make sure the towing vehicle is in good working condition (tires, brakes, lights, etc.) and that current maintenance has been performed on the vehicle.
5. The towing equipment (tow truck, tow bars, etc.) on the towing vehicle must have a rating equal to or greater than the weight of the disabled vehicle being towed.
6. The towing equipment (tow truck, tow bars, etc.) must be mounted or attached to the disabled vehicle's frame. Do not mount or attach the towing equipment to the disabled vehicle's guide wheel equipment.
7. Observe and follow all federal, state and local driving rules, regulations and laws.
8. State laws may require the towing vehicle and disabled vehicle being towed to be equipped with special safety equipment (lights, etc.).
9. Tow the disabled vehicle on the road at a reasonable speed taking into account road conditions, road grade, weather, visibility and stopping distance to assure safe operation. Always observe posted speed limits.



**SECTION 3 - ADJUSTMENTS  
TABLE OF CONTENTS**

3.1 Guide Wheel Equipment Alignment Procedure . . . . . 3 - 2

3.1.1 Vehicle Check . . . . . 3 - 2

3.1.2 Placing Vehicle On Track . . . . . 3 - 3

3.1.3 Guide Wheel Back Flange Gauge . . . . . 3 - 4

3.1.4 Guide Wheel Load . . . . . 3 - 5

3.1.4.1 Checking Front Guide Wheel Load . . . . . 3 - 5

3.1.5 String Lining Set-Up . . . . . 3 - 7

3.1.6 Guide Wheel Alignment . . . . . 3 - 8

3.1.6.1 Checking Guide Wheel Side to Side Alignment . . . . . 3 - 8

3.1.6.2 Adjusting Guide Wheel Side to Side Alignment . . . . . 3 - 8

3.1.6.3 Checking Guide Wheel Tracking . . . . . 3 - 10

3.1.6.4 Adjusting Guide Wheel Tracking . . . . . 3 - 10

3.1.7 Vehicle Track Test . . . . . 3 - 12

3.2 Adjustments . . . . . 3 - 14

3.2.1 Checking Wheel Arm Angle - Rail Position . . . . . 3 - 14

3.2.2 Adjusting Wheel Arm Angle - Rail Position . . . . . 3 - 14

3.2.3 Checking Wheel Arm Stop - Highway Position . . . . . 3 - 15

3.2.4 Adjusting Wheel Arm Stop - Highway Position . . . . . 3 - 15

3.2.5 Checking Vehicle Front Tire Clearance - Rail Position . . . . . 3 - 16

3.2.6 Adjusting Vehicle Front Tire Clearance - Rail Position . . . . . 3 - 16

3.2.7 Brake Shoe Clearance . . . . . 3 - 18

3.2.7.1 Checking Brake Shoe Clearance . . . . . 3 - 18

3.2.7.2 Adjusting Brake Shoe Clearance . . . . . 3 - 18

3.2.8 Rail Sweep Clearance . . . . . 3 - 19

3.2.8.1 Checking Rail Sweep Clearance . . . . . 3 - 19

3.2.8.2 Adjusting Rail Sweep Clearance . . . . . 3 - 19

### 3.1 Guide Wheel Equipment Alignment Procedure



■ **ENGINE MUST BE RUNNING TO OPERATE MECHANICAL PTO HYDRAULIC PUMP TO RAISE / LOWER THE GUIDE WHEELS. BEFORE PERFORMING ANY ADJUSTMENTS TO GUIDE WHEEL EQUIPMENT OR VEHICLE, ALWAYS PLACE AUTOMATIC TRANSMISSION IN "PARK" OR MANUAL TRANSMISSION IN "NEUTRAL". APPLY THE PARKING BRAKE.**

■ **UNDERSTAND EQUIPMENT OPERATION AND BE AWARE OF ALL PINCH POINTS BEFORE OPERATING OR MAKING ADJUSTMENTS TO THE GUIDE WHEEL EQUIPMENT.**

**FAILURE TO HEED THESE WARNINGS COULD RESULT IN SEVERE BODILY INJURY.**

3

The Guide Wheel Alignment Check must be completed when any of the misalignment indicators occur. See Operation - Misalignment Indicators.

See The Operator's Service and Parts Manual provided with the front guide wheel unit for the proper alignment procedure for the front guide wheel unit.

#### 3.1.1 Vehicle Check

1. The vehicle must be at curb weight with permanent attachments: spare tire, tool box less tools, utility box, crane, aerial lift boom, etc. and without: passengers, baggage, load, etc.
2. Weigh the entire vehicle and record this weight. Weigh both the front and rear axles of the vehicle separately and record these weights. These weights will be used when calculating the guide wheel load.
3. The weight of the vehicle should not exceed the GVWR (Gross Vehicle Weight Rating) and the weight on the front and rear axles should not exceed their respective GAWR (Gross Axle Weight Rating).
4. Permanent attachments to the vehicle such as a tool box, utility box, crane, aerial lift boom, etc. which could cause uneven loading on the guide wheels should be compensated for by adjusting the vehicle suspension (adding leaf springs, coil springs, etc).
5. Tires must be inflated to the tire manufacturer's recommended maximum pressure printed on the sidewalls of the tires or wheel manufacturer's recommended maximum pressure, stamped on the wheel, whichever is lower.
6. Visually inspect the entire vehicle, especially the guide wheel equipment, for loose or missing bolts, and bent or damaged components. Tighten, repair, or replace as necessary.

### 3.1 Guide Wheel Equipment Alignment Procedure

#### 3.1.1 Vehicle Check

7. Verify that the vehicle the guide wheel equipment is to be mounted to is equipped correctly (springs, tires, wheels, etc.).
8. Check the following measurements on the vehicle.
  - a. Frame must be square. Diagonal measurements of the frame should be equal within 1/8 inch (3.2 mm).
  - b. Wheelbase (as measured on each side) must be equal within 1/16 inch (1.8 mm).
  - c. Vehicle axles must be square with the frame within 1/64 inch per foot (.4 mm per 304 mm). Harsco Track Technologies, Harsco Corporation recommends that this be checked by a reputable alignment shop.
9. Follow the mounting instructions on the application drawings which are supplied with each Guide Wheel Equipment Group.

*Note: The applicator of the guide wheel equipment must make sure the application drawings remain with the vehicle for further reference. If the application drawings are not with the vehicle, contact Harsco Track Technologies, Fairmont Minnesota Facility to obtain these drawings.*

10. Make sure that the applicator of the guide wheel equipment performed a four point alignment on the vehicle including checking the caster, camber, toe-in on the front wheels and thrust angle of the rear axle. The thrust angle of the rear axle should be set as close to zero as possible. If necessary, adjust to vehicle manufacturer's recommendations.
11. Make sure the headlight aim is checked and adjusted.

#### 3.1.2 Placing Vehicle On Track

1. Place the vehicle on straight, level, tangent track or an alignment rack constructed for guide wheel equipment alignment. If track or an alignment rack is not available, use 4 x 4 inch lumber on a level floor to simulate track. Space the lumber so it measures 56-1/2 inches (1.435 m) between the inside edges.
2. Place the vehicle automatic transmission in "Park" or manual transmission in "Neutral". Apply the parking brake. Lower and lock the guide wheels in the rail position. See Operation - Placing Vehicle On Track.
3. Set the vehicle's front wheels straight ahead. Secure the steering wheel using the steering lock. Stop the engine.

### 3.1 Guide Wheel Equipment Alignment Procedure

#### 3.1.3 Guide Wheel Back Flange Gauge - See Figure 3-1

1. Measure the back flange gauge on the front guide wheel unit. Measure from the back of the left wheel flange, directly below the center line of the wheel spindle, to the same point on the right wheel flange. This dimension must be 53-3/8 to 53-1/2 inches (1356 mm to 1359 mm). The back flange gauge is preset at the factory and is non-adjustable.

FIGURE 3-1  
GUIDE WHEEL BACK FLANGE GAUGE

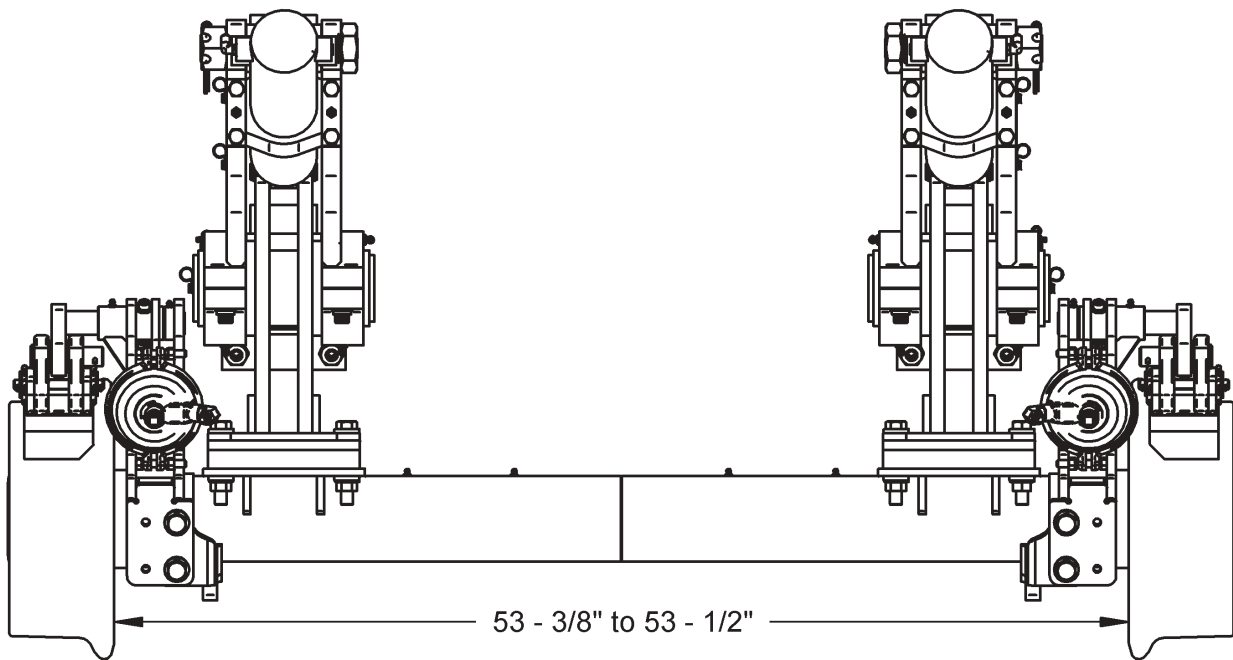

### 3.1 Guide Wheel Equipment Alignment Procedure

#### 3.1.4 Guide Wheel Load



- **IMPROPER LOADING OF GUIDE WHEEL EQUIPMENT CAN CAUSE DERAILMENT OF VEHICLE.**
- **ALWAYS CHECK THE GUIDE WHEEL LOAD BEFORE OPERATING THE VEHICLE ON TRACK.**
- **NEVER OPERATE THE VEHICLE ON TRACK IF LOAD EXCEEDS THE MAXIMUM RATED LOAD OF THE FRONT AND/OR REAR GUIDE WHEEL UNITS. THE MAXIMUM RATED LOAD ON THE REAR GUIDE WHEEL UNIT IS 13,000 LBS (5,896 kg) OR 6,500 LBS (2,948 kg) MAXIMUM PER GUIDE WHEEL.**
- **NEVER OPERATE THE VEHICLE ON TRACK IF CLEARANCE BETWEEN VEHICLE FRONT TIRES AND RAIL IS LESS THAN 1-1/2" (38 mm).**

**FAILURE TO HEED THESE WARNINGS COULD RESULT IN DERAILMENT OF VEHICLE AND/OR SEVERE BODILY INJURY.**

##### 3.1.4.1 Checking Front Guide Wheel Load

1. Whenever the vehicle is loaded or additional load is added to the existing vehicle load on track, check the load on the front guide wheels. The maximum load on the front guide wheel unit is 13,000 lbs (5,896 kg) or 6,500 lbs (2,948 kg) maximum per guide wheel.
2. To check the load on the front guide wheels, the guide wheels must be located on a scale. Check the load on the guide wheel unit and on both guide wheels individually. The load on the guide wheel unit or either guide wheel must not exceed the maximum limits.
3. The load on the guide wheel unit or individual guide wheels is not adjustable. If the load exceeds the maximum allowable limits, some of the load on the vehicle must be removed or repositioned until the load on the guide wheel unit and both guide wheels is within the allowable limits.
4. Also, check the load on the rear guide wheel unit. See the Operator's Service And Parts Manual provided with the rear guide wheel unit for information on checking the load on the rear guide wheel unit.

3.1 Guide Wheel Equipment Alignment Procedure

FIGURE 3-2  
GUIDE WHEEL EQUIPMENT ALIGNMENT

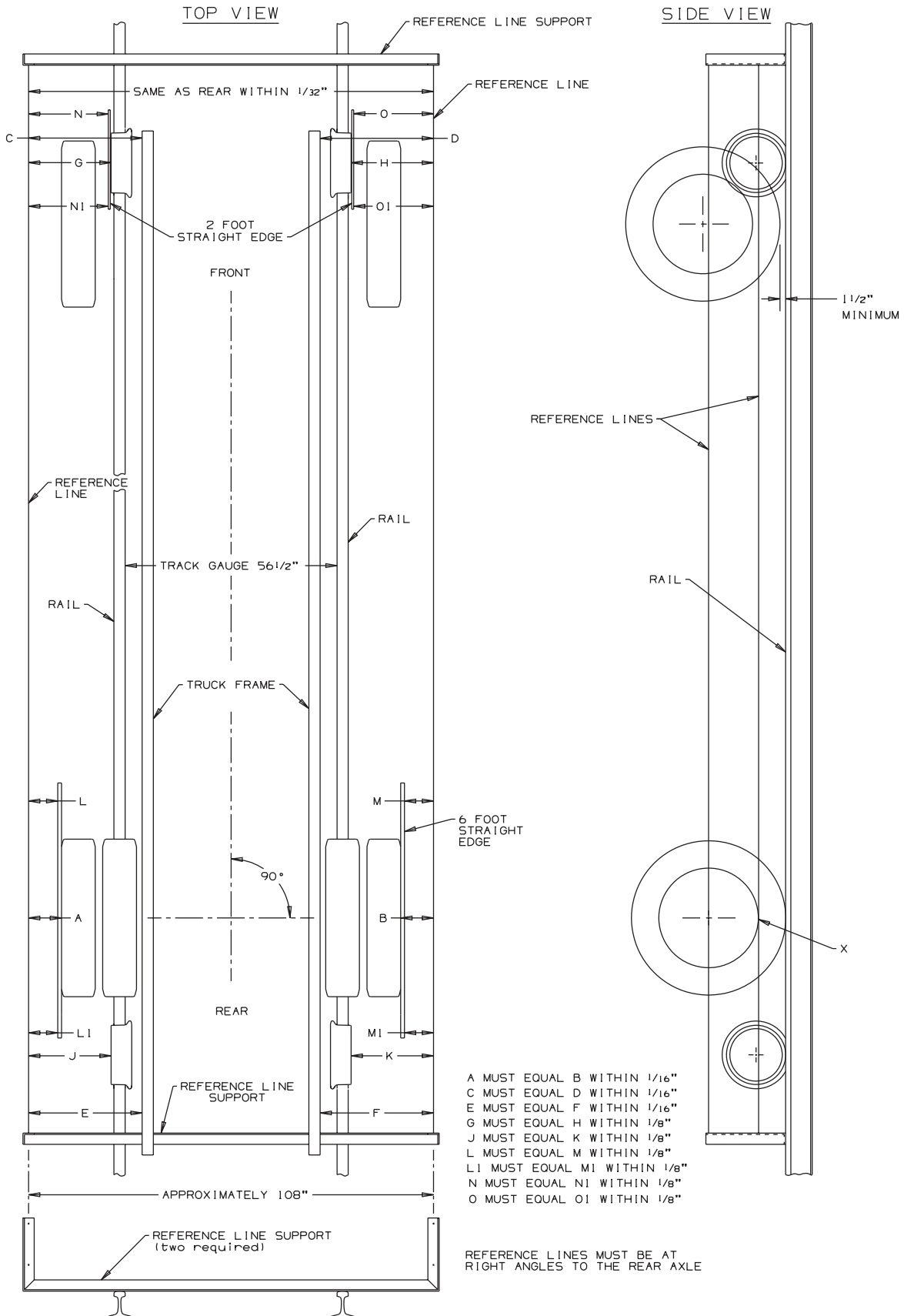

3

### 3.1 Guide Wheel Equipment Alignment Procedure

#### 3.1.5 String Lining Set-Up - See Figure 3-2

1. The string lining procedure is only a guide to check and make alignment adjustments to the guide wheel equipment. String lining the vehicle and guide wheel equipment will not guarantee that the guide wheel equipped vehicle will track properly. Harsco Track Technologies recommends that all HY-RAIL® equipped vehicles be track tested. The vehicle should be at its normal operating load for track testing. The vehicle should be track tested when:
  - a. The guide wheel equipment is installed on the vehicle.
  - b. Any adjustments are made to the guide wheel equipment.
  - c. The load on the vehicle is changed.
  - d. Periodically to ensure that the vehicle is tracking properly.
2. Lower and lock both the front and rear guide wheel units in the "rail" position. See Operation Section - Placing Vehicle On Track. Set the vehicle wheels straight ahead. Secure the vehicle steering wheel using the steering lock.
3. Establish parallel reference lines on each side of the vehicle as shown in Figure 3-2. Parallel reference lines can be established by building two supports or brackets. These can be built out of scrap angle iron or other material. The supports must be high enough so the top reference line is through the center of the rear axle. The supports need to be a few inches longer than the width of the vehicle. Wires or cords stretched between the front and rear supports will be the reference lines. The wires or cords should be spaced approximately 108 inches (2743 mm) apart. The distance between the wires or cords must be equal or within 1/32 inch (.8 mm) at each support.
4. Clamp the supports to the rail in front of and behind the vehicle. The supports should be at right angles to the rail. Stretch the wires or cords between the supports, so the lower reference line is level with the bottom edge of the rear vehicle wheel rim(s) (point X) and the upper reference line is through the center of the rear axle(s). The reference lines must be level.
5. Shift the supports on the rail until dimension A equals (=) B and dimension C equals (=) D or within 1/16 inch (1.6 mm). Measurements A and B should be taken from the edge of the rear vehicle rim(s) directly below the axle (point X) to the reference lines. Measurements C and D are taken from the front of the vehicle frame. When shifting the supports, keep them at right angles to the rail so the reference lines stay level and parallel to each other.
6. Hold a six (6) foot straight edge against the outer edge of the rear, outside tires with the straight edge centered on the tires. Record dimensions L, L1, M and M1 to the reference line. Rotate the rear tires 180 degrees and record a second set of dimensions at L, L1, M and M1. Average the two dimensions taken at L, L1, M and M1.

Example: [ L (first dimension) + L (second dimension)] ÷ 2 = L (average dimension)

### 3.1 Guide Wheel Equipment Alignment Procedure

#### 3.1.5 String Lining Set-Up - See Figure 3-2

7. Shift the supports on the rail until dimension L (average) equals (=) M (average) and dimension L1 (average) equals (=) M1 (average) or within 1/8 inch (3.2 mm). When shifting the supports, keep them at right angles to the rail so the reference lines stay level and parallel to each other. The reference lines will be parallel only when the rear axle is straight.
8. After the reference lines have been established, measurements can be taken from these lines to the guide wheels to help ensure correct alignment.

3

#### 3.1.6 Guide Wheel Alignment

##### 3.1.6.1 Checking Guide Wheel Side to Side Alignment - See Figure 3-2

1. Take measurements G and H. Measure from the outer edge of the guide wheel, directly below the center line of the wheel spindle, to the reference lines. Check that dimension G equals (=) H or is within 3/16 inch (4.8 mm). If not, determine the amount of side to side adjustment that will be required.

##### 3.1.6.2 Adjusting Guide Wheel Side to Side Alignment - See Figures 3-2, 3-3

1. Move the control valve handle to raise the guide wheels until all weight of the vehicle is removed from the guide wheel unit. Let the guide wheels rest on the rails.
2. Make sure the parking brakes are applied. Stop the vehicle engine.
3. Adjustment is accomplished by loosening the eight axle mounting fasteners (1) and moving the axle (2). The mounting plates on the axle are slotted for side to side adjustment.

*Note: The axle mounting plates on the wheel arms are slotted for forward and rearward adjustment. Make sure when moving the axle side to side that the axle forward / rearward position does not change.*

4. Adjust the side to side alignment of the front guide wheel unit (dimensions G and H are equal or within 3/16 inch).
  - a. If dimension G is greater than dimension H, move the axle to the left one-half (1/2) of the measured difference between G and H.
  - b. If dimension H is greater than dimension G, move the axle to the right one-half (1/2) of the measured difference between G and H.
5. Tighten the eight axle mounting fasteners (1) securely.
6. Start the vehicle engine. Lower the guide wheels to the rail position.



### 3.1 Guide Wheel Equipment Alignment Procedure

#### 3.1.6 Guide Wheel Alignment

##### 3.1.6.2 Adjusting Guide Wheel Side to Side Alignment

7. Recheck measurements G and H. Check that dimension G equals (=) H or is within 3/16 inch (4.8 mm). If not, repeat the procedure until dimension G equals (=) H or is within 3/16 inch (4.8 mm).

FIGURE 3-3  
GUIDE WHEEL ALIGNMENT

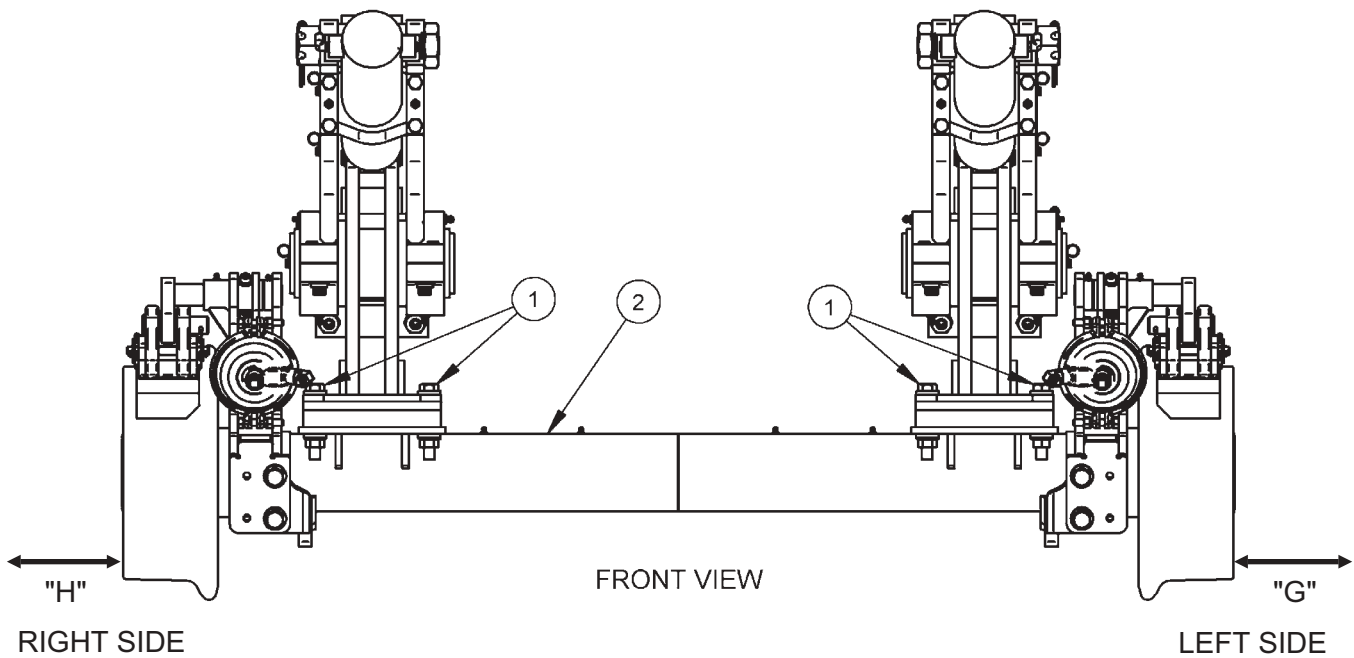

### 3.1 Guide Wheel Equipment Alignment Procedure

#### 3.1.6 Guide Wheel Alignment

##### 3.1.6.3 Checking Guide Wheel Tracking - See Figure 3-2

1. The front guide wheels must track straight. Hold a two foot long straight edge against the outer edge of the front guide wheel. Take measurements N and N 1 and measurements O and O1. Check that dimension N equals (=) N 1 and that dimension O equals (=) O 1 or they are within 1/8 inch (3.2 mm). If not, adjustment is required.

##### 3.1.6.4 Adjusting Guide Wheel Tracking - See Figures 3-2, 3-4 and 3-5

3

1. Move the control valve handle to raise the guide wheels until all weight of the vehicle is removed from the guide wheel unit. Let the guide wheels rest on the rails.
2. Make sure the parking brakes are applied. Stop the vehicle engine.
3. Adjustment is accomplished by loosening the eight axle mounting fasteners (1) and moving the axle (2). The mounting plates on the wheel arms are slotted for forward and rearward adjustment.

*Note: The axle mounting plates on the axle assembly are slotted for side to side adjustment. Make sure when moving the axle forward / rearward that the axle side to side position does not change.*

4. Adjust the guide wheel tracking until dimension N equals (=) N 1 and that dimension O equals (=) O 1 or they are within 1/8 inch (3.2 mm).
  - a. If dimension N is greater than N1 and dimension O is less than O1, move the left end of the axle rearward or the right end of the axle forward.
  - b. If dimension N is less than N1 and dimension O is greater than O1, move the right end of the axle rearward or the left end of the axle forward.
5. Tighten the eight axle mounting fasteners (1) securely.
6. Start the vehicle engine. Lower the guide wheels to the rail position.
7. Recheck measurements N and N 1 and measurements O and O 1. Check that dimension N equals (=) N 1 and that dimension O equals (=) O 1 or they are within 1/8 inch (3.2 mm). If not, repeat the procedure until dimension N equals (=) N1 and dimension O equals (=) O1 or they are within 1/8 inch (3.2 mm)
8. Recheck measurements G and H to ensure the side to side alignment has not changed.

### 3.1 Guide Wheel Equipment Alignment Procedure

#### 3.1.6 Guide Wheel Alignment

FIGURE 3-4  
GUIDE WHEEL ALIGNMENT

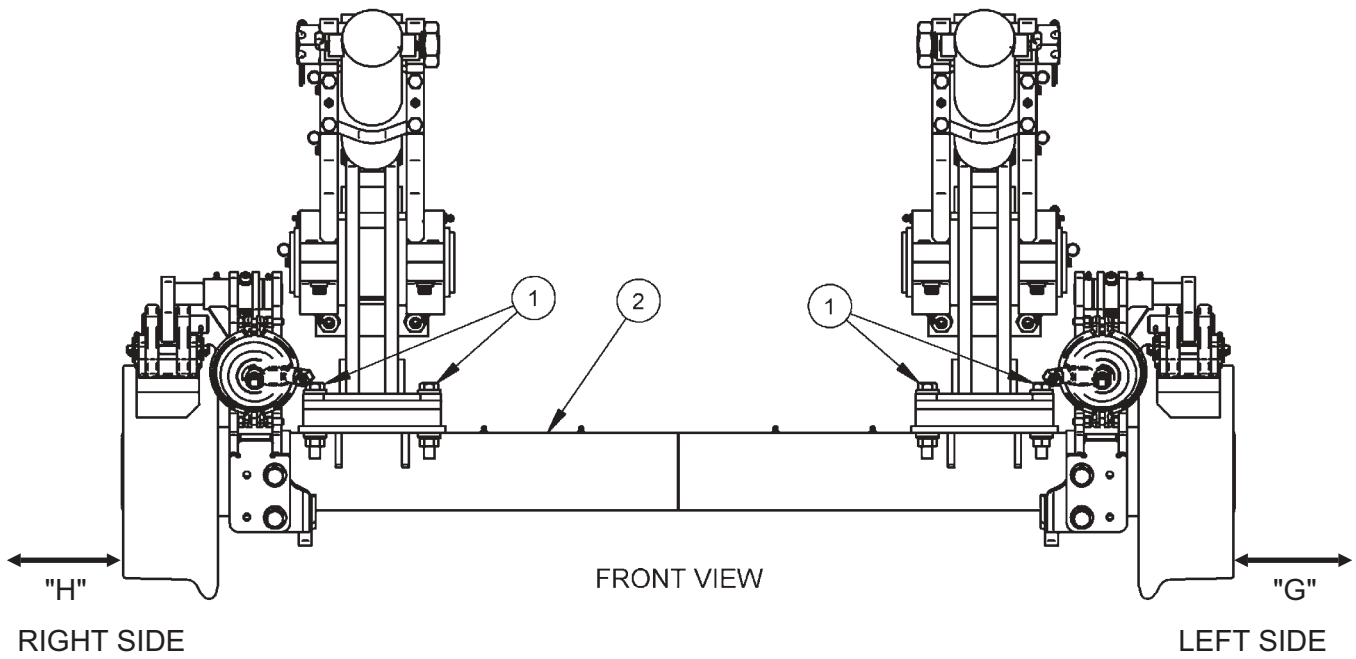

3

FIGURE 3-5  
GUIDE WHEEL ALIGNMENT

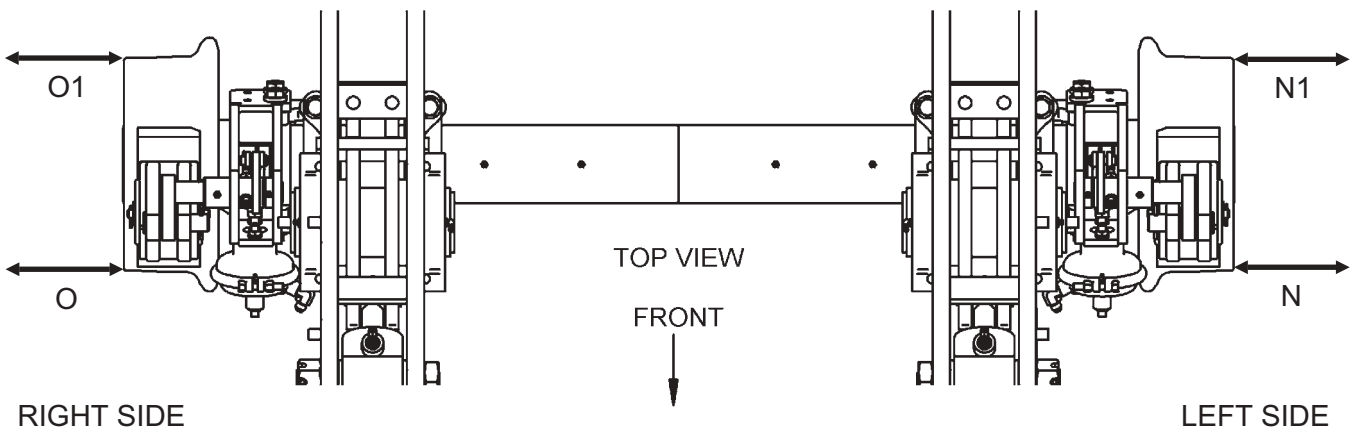

### 3.1 Guide Wheel Equipment Alignment Procedure

#### 3.1.7 Vehicle Track Test



■ **CHECK AND CORRECT ALIGNMENT PROMPTLY IF MISALIGNMENT IS INDICATED. MISALIGNMENT OF GUIDE WHEEL EQUIPMENT COULD RESULT IN DERAILMENT OF THE VEHICLE AND SEVERE BODILY INJURY.**

3

1. Harsco Track Technologies recommends that all HY-RAIL® equipped vehicles be track tested. The vehicle should be at its normal operating load for track testing. The vehicle should be track tested when:
  - a. The guide wheel equipment is installed on the vehicle.
  - b. Any adjustments are made to the guide wheel equipment.
  - c. The load on the vehicle is changed.
  - d. Periodically to ensure that the vehicle is tracking properly.
2. The vehicle must be placed on straight, level, tangent track. See Operation Section - Placing Vehicle On Track.
3. Apply spray paint to the flanges and treads of all guide wheels.
4. Lower and lock both guide wheel units in the "rail" position.
5. Operate the vehicle a minimum of 1/4 mile at a normal operating speed.
6. The paint should wear evenly around the flanges and treads of all guide wheels. If the paint is worn evenly on all guide wheels, the vehicle and guide wheel equipment is properly aligned.
7. If the paint wore off the right front guide wheel flange and not off the left front guide wheel flange, the guide wheel unit is "flanging right".
  - a. Raise the guide wheel unit from the "rail" position. Let the guide wheels rest on the rail. See Adjusting Guide Wheel Tracking. Slightly move the right side of the guide wheel unit forward or the left side of the guide wheel unit rearward.
  - b. Repaint the flanges and treads on all guide wheels. Lower and lock the guide wheel unit in the "rail" Position. Operate the vehicle a minimum of 1/4 mile at a normal operating speed. If the paint is worn evenly on all guide wheels, the vehicle and guide wheel equipment is properly aligned.
  - c. If the paint continues to wear off the right front guide wheel flange and not off the left front guide wheel flange, repeat Steps a. and b.

### 3.1 Guide Wheel Equipment Alignment Procedure

#### 3.1.7 Vehicle Track Test

8. If the paint wore off the left front guide wheel flange and not off the right front guide wheel flange, the guide wheel unit is "flanging left".
  - a. Raise the guide wheel unit from the "rail" position. Let the guide wheels rest on the rail. See Adjusting Guide Wheel Tracking. Slightly move the left side of the guide wheel unit forward or the right side of the guide wheel unit rearward.
  - b. Repaint the flanges and treads on all guide wheels. Lower and lock the guide wheels in the "rail" Position. Operate the vehicle a minimum of 1/4 mile at a normal operating speed. If the paint is worn evenly on all guide wheels, the vehicle and guide wheel equipment is properly aligned.
  - c. If the paint continues to wear off the left front guide wheel flange and not off the right front guide wheel flange, repeat Steps a. and b.
9. If the preceding procedure did not correct the tracking problem, note which guide wheels, flange and/or tread the paint is worn on.
  - a. Repaint the flanges and treads on all guide wheels.
  - b. Operate the vehicle in reverse for a short distance at a normal operating speed.
  - c. Note which guide wheels, flange and/or tread the paint is worn on.

If the paint wore off the right front flange when traveling forward and then off the left rear flange when traveling in reverse or off the left front flange when traveling forward and then off the right rear flange when traveling in reverse, the vehicle is probably not aligned properly. Have the frame checked for proper alignment. See Vehicle Check.
10. If the vehicle continues to track improperly, repeat the String Lining and Guide Wheel Alignment Procedure.

## 3.2 Adjustments

### 3.2.1 Checking Wheel Arm Angle - Rail Position - See Figure 3-6

1. Both wheel arms need to be set to  $20^\circ \pm 1^\circ$  rearward from vertical to provide the proper over-center position. Use an angle measuring device to check the angle on both wheel arms. If both wheel arms are at  $20^\circ \pm 1^\circ$  rearward from vertical, they are set correctly. If not, adjustment is required.

### 3.2.2 Adjusting Wheel Arm Angle - Rail Position - See Figure 3-6

1. Move the control valve handle to raise the guide wheels until all weight of the vehicle is removed from the guide wheel unit. Let the guide wheels rest on the rails.
  2. Make sure the parking brakes are applied. Stop the vehicle engine.
  3. Adjustment is accomplished by adjusting set screws (2). There are two set screws on each wheel arm. Loosen jam nut (1).
    - a. If the measured angle is less than  $20^\circ \pm 1^\circ$ , turn the set screws counter-clockwise.
    - b. If the measured angle is greater than  $20^\circ \pm 1^\circ$ , turn the set screw clockwise.
    - c. Adjust both set screws on the wheel arm equally. Tighten the jam nut.
4. Start the vehicle engine. Lower the guide wheels to the rail position.
  5. Make sure both set screws are adjusted equally against the upper structure. Re-check the angle of the wheel arms. If the wheel arms are at  $20^\circ \pm 1^\circ$  rearward from vertical, they are set correctly. If not, repeat the procedure until the wheel arms are set correctly.

FIGURE 3-6  
WHEEL ARM ANGLE - RAIL POSITION

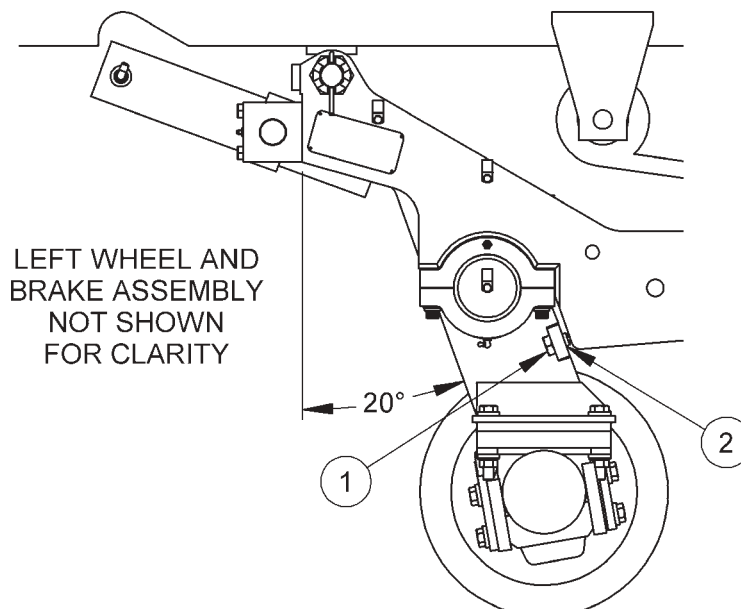

### 3.2 Adjustments

#### 3.2.3 Checking Wheel Arm Stop - Highway Position - See Figure 3-7

1. The wheel arm stop set screws are used to adjust the the wheel arms when they are in the "highway" position. The wheel arm set screws may need to be adjusted to ensure clearance of guide wheel unit components and vehicle components when the unit is in the "highway" position.
2. Slowly raise the guide wheels from the "rail" position. Visually observe the guide wheel components to ensure they do not interfere with any vehicle components. The wheel arms must also rest against the set screws to ensure the unit does not bounce when traveling on the highway. If not, adjustment is required.

3

#### 3.2.4 Adjusting Wheel Arm Stop - Highway Position - See Figure 3-7

1. Move the control valve handle to lower the guide wheels. Let the guide wheels rest on the rails.
2. Make sure the parking brakes are applied. Stop the vehicle engine.
3. Adjustment is accomplished by adjusting set screws (2). There are two set screws on each upper structure. Loosen jam nut (1).

  - a. To increase the guide wheel raise, turn the set screws counter-clockwise.
  - b. To decrease the guide wheel raise, turn the set screw clockwise.
  - c. Adjust both set screws on the wheel arm equally. Tighten the jam nut.

4. Start the vehicle engine. Lower the guide wheels to the rail position.
5. Make sure both set screws are adjusted equally against the wheel arm. Re-check the guide wheel unit clearance to ensure it is acceptable. If not, repeat the procedure until the clearance is acceptable.

FIGURE 3-7  
WHEEL ARM STOP - HIGHWAY POSITION

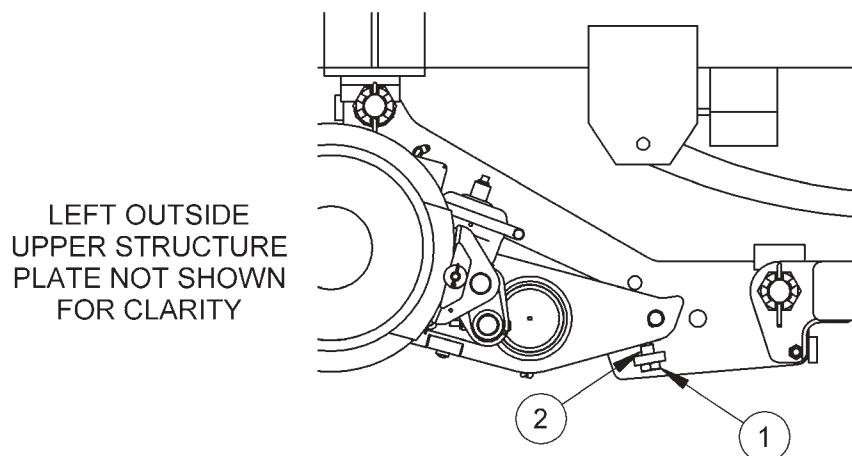

## 3.2 Adjustments

### 3.2.5 Checking Vehicle Front Tire Clearance - Rail Position - See Figure 3-8

The vehicle's front tire clearance should be checked whenever the vehicle is placed on rail or whenever the load on the vehicle is changed significantly.

1. Place the vehicle on straight, level, tangent track. Place the vehicle automatic transmission in "Park" or manual transmission in "Neutral". Apply the parking brake. Lower both guide wheel units in the "rail" position. See Operation Section - Placing Vehicle On Track.
2. When the front guide wheels are lowered and locked in the "rail" position, the guide wheel unit suspension linkage will raise the vehicle's front tires above the rails. This is necessary to ensure clearance when the vehicle passes through switches, turnouts, crossings, frogs, etc. As the vehicle is loaded, the front tire clearance will decrease. The front tires must always clear the top of the rails by a minimum of 1-1/2 inches (38 mm) whenever the vehicle is on track. If not, adjustment is required.

### 3.2.6 Adjusting Vehicle Front Tire Clearance - Rail Position - See Figure 3-8

1. Determine the amount of shim that will be required to obtain the minimum of 1-1/2 inches (38 mm) of tire clearance above the rail. As an example: if there is only 1 inch of clearance, an additional 1/2 inch of shim will need to be added between the unit rear mounts and the vehicle springs.
2. Move the control valve handle to raise the guide wheels to the "highway" position.
3. Make sure the parking brakes are applied. Stop the vehicle engine.
4. Place floor jack(s) and blocks under the rear of the guide wheel unit to prevent it from falling. Also, the jack(s) are necessary to lower the rear of the unit to add shims and then raise it back in place.
5. Loosen and remove the hex nuts (1) from the rod assembly (2). Remove the pads and any shims (3) from above the springs.
6. Using the jack(s), lower the rear of the unit until the required number of shims (3) can be added to the rod assembly.
7. Jack the rear of the unit back up until the shims are against the springs. Make sure that the rod assemblies are located on the springs in the same position (same distance from the vehicle axle) as they were before being removed.
8. Re-install the pad and any extra shims above the springs. Install the hex nuts and tighten securely.



### 3.2 Adjustments

#### 3.2.6 Adjusting Vehicle Front Tire Clearance - Rail Position - See Figure 3-8

9. Remove the blocks and jack(s) from under the vehicle.
10. Start the vehicle engine. Lower the guide wheels to the rail position. Check to ensure there is a minimum of 1-1/2 inches (38 mm) of tire clearance above the rail. If not, repeat the procedure until the correct tire clearance is obtained.

FIGURE 3-8  
VEHICLE FRONT TIRE CLEARANCE

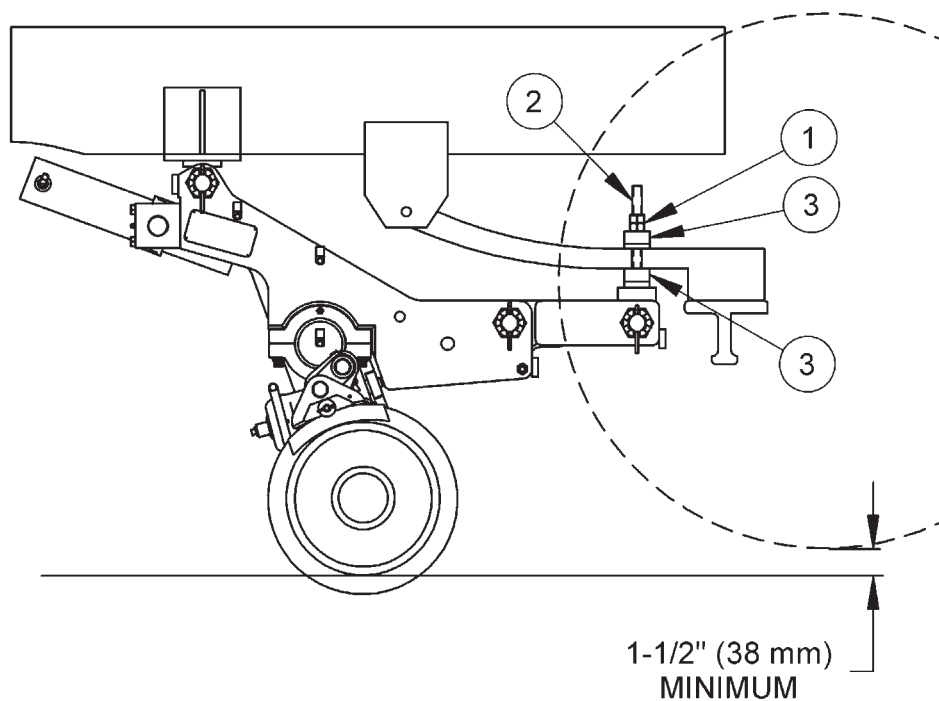

## 3.2 Adjustments

### 3.2.7 Brake Shoe Clearance

#### 3.2.7.1 Checking Brake Shoe Clearance - See Figure 3-9

1. Place the vehicle automatic transmission in "Park" or manual transmission in "Neutral". Apply the parking brake.
2. Measure the clearance between the brake shoe and the guide wheel tread. The clearance must not exceed 1/8 inch (3.2 mm), or adjustment is required.
3. Repeat Step 2 to check the brake shoe clearance on the other guide wheel brake.

#### 3.2.7.2 Adjusting Checking Brake Shoe Clearance - See Figure 3-9

1. Remove the cotter pin from the pin (1). Remove the pin (1) from the yoke (2) on the brake actuator (3). Loosen jam nut (4) and turn yoke (2) counter-clockwise to adjust the brake shoe closer to the guide wheel tread or clockwise to adjust the brake shoe away from the guide wheel tread.
2. Adjust so the brake shoe is 1/32 - 1/16 inch (.8 - 1.6 mm) away from the guide wheel tread. Install the pin (1) through the yoke (2) and brake arm (5) and secure using the cotter pin. Tighten jam nut (4) securely. Recheck the brake shoe clearance.
3. Repeat this procedure to adjust the brake shoe clearance on the other guide wheel brake.

FIGURE 3-9  
BRAKE SHOE CLEARANCE

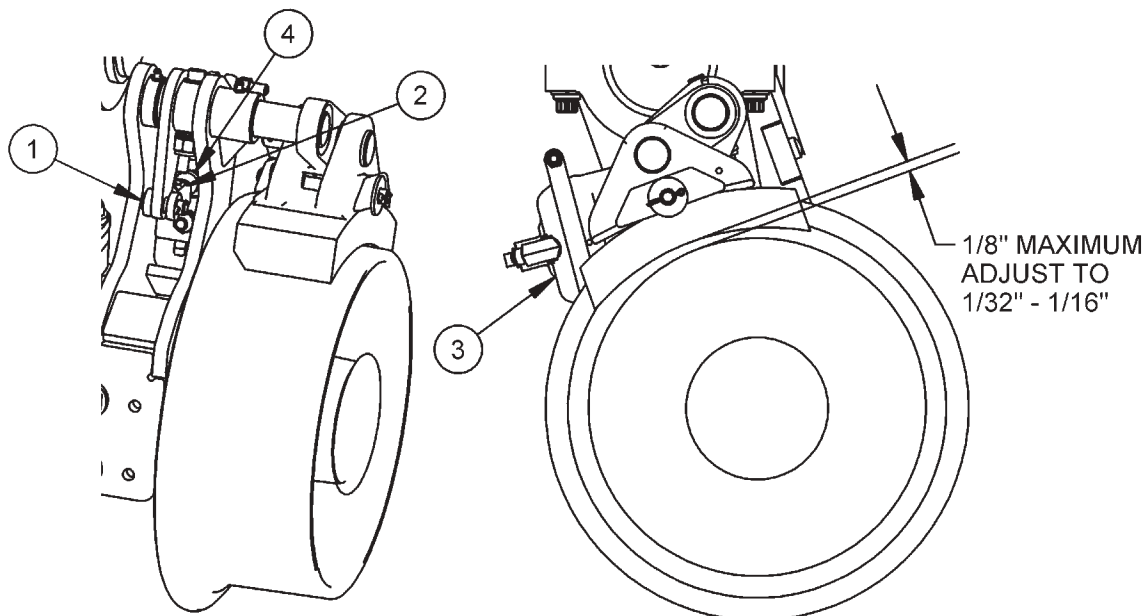

## 3.2 Adjustments

### 3.2.8 Rail Sweep Clearance

#### 3.2.8.1 Checking Rail Sweep Clearance - See Figure 3-10

1. Place the vehicle on straight, level track. Place the vehicle automatic transmission in "Park" or manual transmission in "Neutral". Apply the vehicle parking / emergency brake. Lower and lock the front and rear guide wheels in the "rail" position.
2. The rubber rail sweeps should clear the top of the rail by  $3/16$  inch (4.8 mm). If not, see Adjustment.

#### 3.2.8.2 Adjusting Rail Sweep Clearance - See Figure 3-8

1. Loosen the two hex nuts (1) on cap screws (2). Slide the rubber sweep (3) down until it clears the top of the rail by  $3/16$  inch (4.8 mm). Re-tighten the two hex nuts (1) and cap screws (2).
2. Repeat this procedure to adjust the rail sweep clearance on the other guide wheel.
3. When the rubber sweep is worn so it cannot be adjusted, replace the rubber sweep (3).

FIGURE 3-10  
RAIL SWEEP CLEARANCE

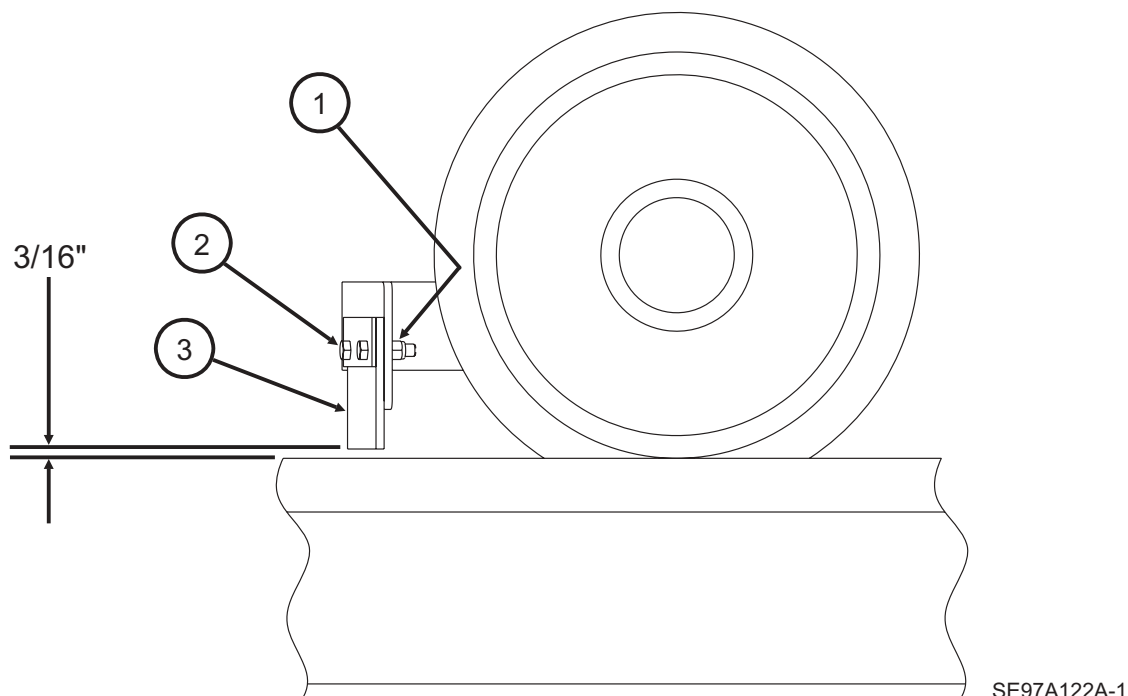



**SECTION 4 - MAINTENANCE  
TABLE OF CONTENTS**

4.1	Maintenance Schedule . . . . .	4 - 2
4.1.1	Daily . . . . .	4 - 2
4.1.2	Weekly . . . . .	4 - 2
4.1.3	At 2,000 Track Miles (3200 km) . . . . .	4 - 3
4.1.4	At 10,000 Track Miles (16000 km) . . . . .	4 - 3
4.2	Waste Disposal . . . . .	4 - 3
4.3	Guide Wheel Equipment Lubrication . . . . .	4 - 4
4.3.1	Guide Wheel Unit Lubrication . . . . .	4 - 4
4.3.2	Re-Packing Guide Wheel Bearings. . . . .	4 - 5
4.4	Guide Wheels. . . . .	4 - 6
4.4.1	Allowable Wear. . . . .	4 - 6
4.5	Vehicle Wheels. . . . .	4 - 7
4.5.2	Tire Replacement . . . . .	4 - 7
4.6	Bolt Torque Requirements . . . . .	4 - 7
4.7	Hoses And Fittings. . . . .	4 - 8
4.7.1	Inspection, Maintenance, Replacement And Installation. . . . .	4 - 8
4.7.2	Hose Band . . . . .	4 - 8

## 4.1 Maintenance Schedule



■ **RE-TORQUE VEHICLE WHEEL LUG NUTS AND GUIDE WHEEL LUG NUTS AFTER THE FIRST 50 MILES OF OPERATION. THEREAFTER TORQUE WHEEL LUG NUTS ACCORDING TO VEHICLE MANUFACTURER'S WHEEL TORQUE SPECIFICATIONS. FAILURE TO COMPLY COULD RESULT IN SEVERE BODILY INJURY.**

### 4.1.1 Daily

1. Inspect the front and rear guide wheel units for damaged, worn or missing parts.
2. Check the mechanical and hydraulic locks and lock pins for ease of operation.
3. Check the hydraulic reservoir to ensure that the oil level is full. If low, fill to the proper level with the correct fluid.
4. When the vehicle is operated on the track, listen for unusual noises. Unusual noises may indicate incorrectly lowered guide wheels, damaged or missing parts, or insufficient lubrication. Pay attention to the quality of the ride. Check the guide wheel equipment alignment if the vehicle crowds one side of the track instead of floating from side to side. See Adjustments - Guide Wheel Equipment Alignment Procedure.

4

### 4.1.2 Weekly

1. Check the guide wheel equipment alignment. See Adjustment Section, Guide Wheel Equipment Alignment Procedure - Vehicle Track Test.
2. Inspect the guide wheel tread and flanges for wear or damage. See Maintenance - Guide Wheel Allowable Wear.
3. Spin each guide wheel by hand, checking for ease of rotation. If the guide wheel does not rotate easily, the guide wheel bearings may be lacking lubrication or may be damaged. Inspect, re-pack or replace the bearings if necessary.
4. Inspect the vehicle wheels, studs, lug nuts and tires for wear, damage, cuts etc.
5. Check the vehicle tires for correct inflation pressure. Operate at the tire manufacturer's recommended maximum pressure printed on the sidewalls of the tires, or the wheel manufacturer's recommended maximum pressure stamped on the wheel, whichever is lower.
6. Check all bolts for tightness. See Appendix A for bolt torque specification tables and grade identification markings used by manufacturers.

## 4.1 Maintenance Schedule

### 4.1.3 Every 2,000 Track Miles (3200 km):

Lubricate the guide wheel unit locations provided with grease fittings. See Guide Wheel Equipment Lubrication.

### 4.1.4 At 10,000 Track Miles (16000 km):

Re-pack and adjust the guide wheel bearings. See Re-packing Guide Wheel Bearings.

## 4.2 Waste Disposal

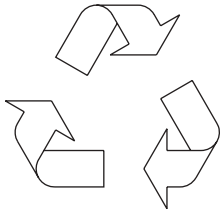

Dispose of waste properly. Improper disposal of waste can threaten the environment. The operation and maintenance of Harsco Track Technologies equipment may involve the use of such items as hydraulic oil, engine oil, fuel, coolant, brake fluid, filters, batteries, etc.

Use leak proof containers when draining fluids. Do not pour waste onto the ground, down a drain, or into any water source. Inquire on the proper way to recycle or dispose of waste according to applicable Federal, State and/or local regulations.

### 4.3 Guide Wheel Equipment Lubrication

Lubricate the guide wheel equipment every 2000 track miles (maximum) or each time the vehicle is serviced.

#### 4.3.1 Guide Wheel Unit Lubrication - See Figure 4-1

1. Apply the vehicle parking brake. Stop the vehicle engine. Turn the vehicle's ignition switch off.
2. Lubricate grease fittings (A) using Mobil Special Moly, or equivalent.
3. Re-pack the guide wheel bearings (B) every 10,000 track miles (maximum) or at least once yearly (minimum), whichever occurs first. See Re-packing Guide Wheel Bearings.

FIGURE 4-1  
GUIDE WHEEL UNIT LUBRICATION

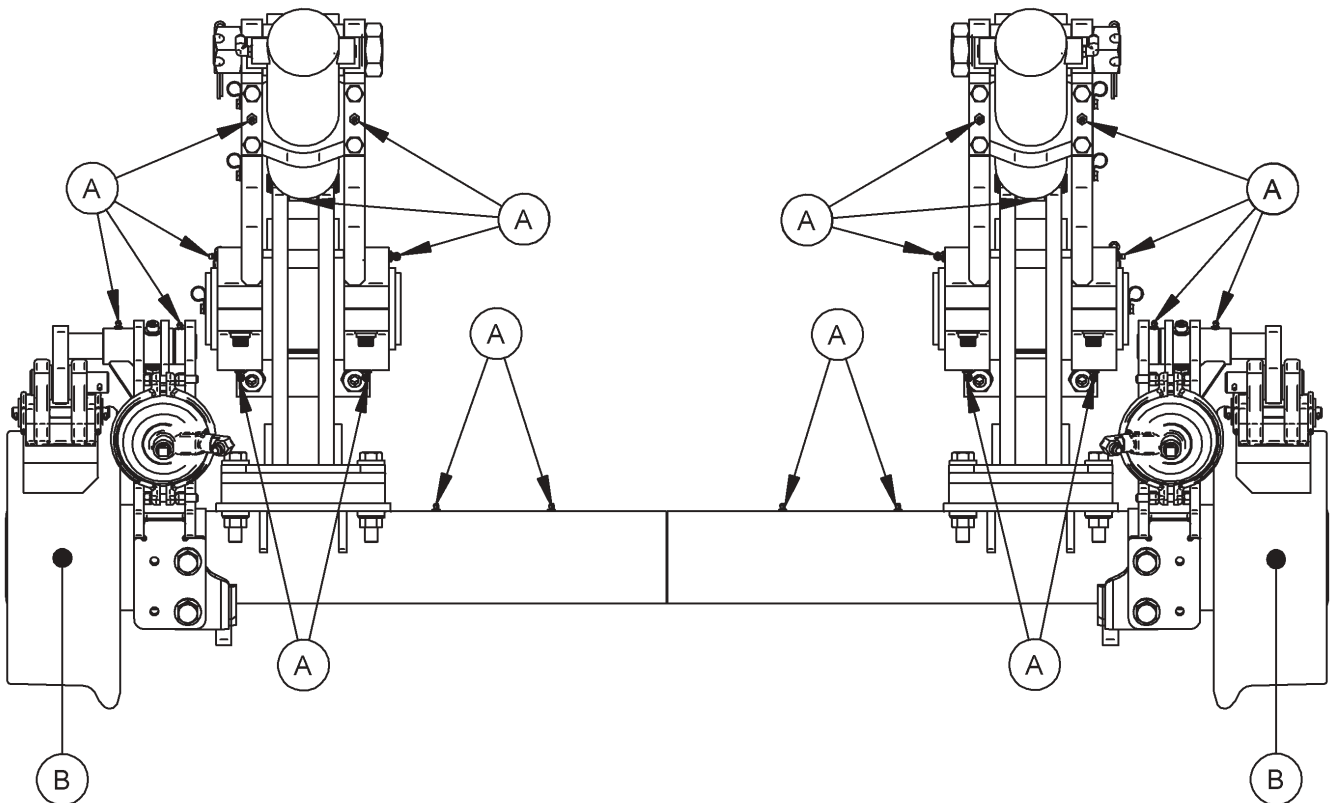



### 4.3 Guide Wheel Equipment Lubrication

#### 4.3.2 Re-Packing Guide Wheel Bearings - See Figure 4-2

Re-pack the guide wheel bearings every 10,000 track miles (maximum) or at least once yearly (minimum), whichever occurs first.

1. Apply the parking brake. Raise and lock the front and rear guide wheel units in the "highway" position. Stop the vehicle engine. Shut off the vehicle ignition switch.
2. Remove the hub cap (1). Remove the 3/16 x 2-1/2 inch cotter pin (2), 1-1/2 inch castle nut (3) and spindle washer (4).
3. Pull the guide wheel (5) from the spindle (6). Remove the outer bearing cone (7) from the guide wheel (5). Remove the grease seal (11) and inner bearing cone (9) from the guide wheel (5).
4. Clean all components of old grease and dirt.
5. Inspect the spindle, bearing cones and cups (7 & 8, 9 & 10) for nicks, gouges and wear. If any of these are evident, replace the component.
6. Measure the guide wheel wear. See Maintenance - Guide Wheels, Allowable Wear.
7. Coat the spindle surface, grease seal surface, both bearing cup surfaces, pack both bearing cones and fill the guide wheel cavity 1/2 full (50 %) using Mobil HP grease, or equivalent.
8. Install the inner bearing cone (9) into the guide wheel (5). Install a new grease seal (11) into the wheel.
9. Slide the guide wheel (5) with the inner bearing (9) and grease seal (11) onto the spindle (6). Install the outer bearing cone (7), spindle washer (4) and 1-1/2 inch castle nut (3) onto the spindle (6).
10. Torque the castle nut (3) to approximately 20 ft lbs. Then loosen the castle nut. This is especially important if new bearing cups have been installed.
11. Torque the castle nut (3) to 7 ft lbs (zero clearance). Then back the castle nut off 1/2 to 1 flat of the nut (.001 - .010 inch clearance). Secure the castle nut using a new cotter pin (2).
12. Install the hub cap (1) onto the guide wheel.

FIGURE 4-2  
RE-PACKING GUIDE WHEEL  
BEARINGS

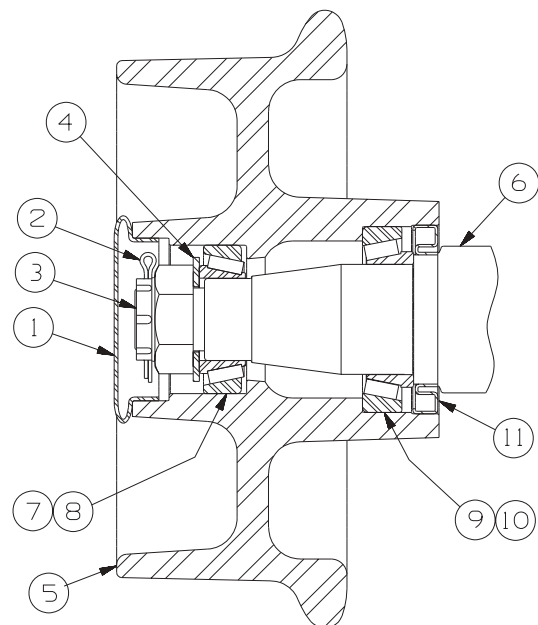

## 4.4 Guide Wheels

### 4.4.1 Allowable Wear - See Figure 4-3



■ **REPLACE ANY GUIDE WHEEL IMMEDIATELY WHICH SHOWS DAMAGE AND/OR HAS WORN MORE THAN THE ALLOWABLE LIMITS. FAILURE TO COMPLY COULD RESULT IN DERAILMENT OF THE VEHICLE, AND SEVERE BODILY INJURY.**

The guide wheels must be checked for allowable wear a minimum of once yearly (every twelve months). Use the following procedure to check the guide wheel wear.

1. Tools needed: Harsco Track Technologies wheel caliper (M019889), or equivalent.
2. Measure the guide wheel flange at Position "A" with the wheel caliper. The minimum allowable flange dimension at Position "A" is 7/8 inch (22.2 mm).

4

If the guide wheel flange dimension is less than the allowable limit, replace the guide wheel immediately.

3. Measure the guide wheel tread at Position "B" with the wheel caliper. The minimum allowable tread dimension at Position "B" is 1/2 inch (12.7 mm).

If the guide wheel tread dimension is less than the allowable limit, replace the guide wheel immediately.

4. The entire guide wheel must not have any gouges or cracks. If any of these are evident, replace the guide wheel immediately.

FIGURE 4-3  
ALLOWABLE GUIDE WHEEL WEAR

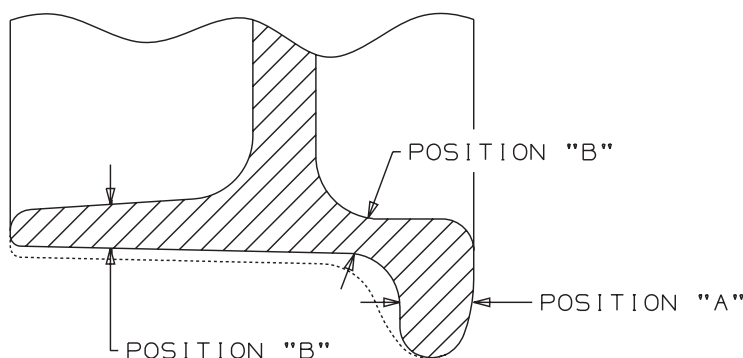

SE93A124A-1

## 4.5 Vehicle Wheels

### 4.5.1 Tire Replacement



- **USE REPLACEMENT TIRES WITH THE SAME ROLLING RADIUS, TREAD WIDTH, PLY RATING, AND LOAD RATING AS RECOMMENDED BY THE VEHICLE MANUFACTURER. FAILURE TO COMPLY COULD RESULT IN BODILY INJURY AND/OR PROPERTY DAMAGE.**

Replacement tires must have the same rolling radius, tread width, ply rating, and load rating as recommended by the vehicle manufacturer. Using tires of equal diameter will help keep the speedometer reading and the guide wheel load accurate. Tires must have a minimum 6-1/2 inches of tread width. After installing new tire(s) on the vehicle, check guide wheel load. See the Adjustment Section - Guide Wheel Equipment Alignment Procedure.

Inflate tires to the tire manufacturer's recommended maximum pressure printed on the sidewalls of the tires or the wheel manufacturer's recommended maximum pressure stamped on the wheel, whichever is lower. The wheels and tires should be static balanced or balanced after installation on the vehicle for the best results. Torque vehicle wheel lug nuts to manufacturer's recommended specifications.

4

## 4.6 Bolt Torque Requirements



- **CHECK ALL BOLTS AND NUTS PERIODICALLY. KEEP BOLTS AND NUTS TIGHTENED TO THE TORQUE SPECIFIED IN APPENDIX A. IF BOLT REPLACEMENT BECOMES NECESSARY, REPLACE WORN BOLT WITH EQUAL S.A.E. GRADE NUMBER BOLT. FAILURE TO COMPLY COULD RESULT IN BODILY INJURY, AND/OR PROPERTY DAMAGE.**

See Appendix A for bolt torque specification tables and grade identification markings used by manufacturers.

### 4.7 Hoses and Fittings



■ ALL HOSES AND FITTINGS ON THIS EQUIPMENT MUST COMPLY WITH SAE STANDARD J1273 RECOMMENDED PRACTICE FOR SELECTION, INSTALLATION AND MAINTENANCE OF HOSE AND HOSE ASSEMBLIES. FAILURE TO COMPLY TO THIS STANDARD COULD RESULT IN SEVERE BODILY INJURY.

#### 4.7.1 Inspection, Maintenance, Replacement And Installation

The inspection, maintenance, replacement and installation of hydraulic hose assemblies and fittings on this equipment must conform with SAE Standard J1273. See Appendix B.

#### 4.7.1 Hose Band - See Figure 4-4

All Harsco Track Technologies original and replacement hose assemblies manufactured for this equipment at the Harsco Track Technologies, Harsco Corporation Fairmont, Minnesota plant facility are supplied with a hose band displaying the date of manufacture and the Harsco Track Technologies part number. The hose assembly illustrated in the example was manufactured in May 2006 and is Harsco Track Technologies part number 188662.

FIGURE 4-4  
HOSE BAND

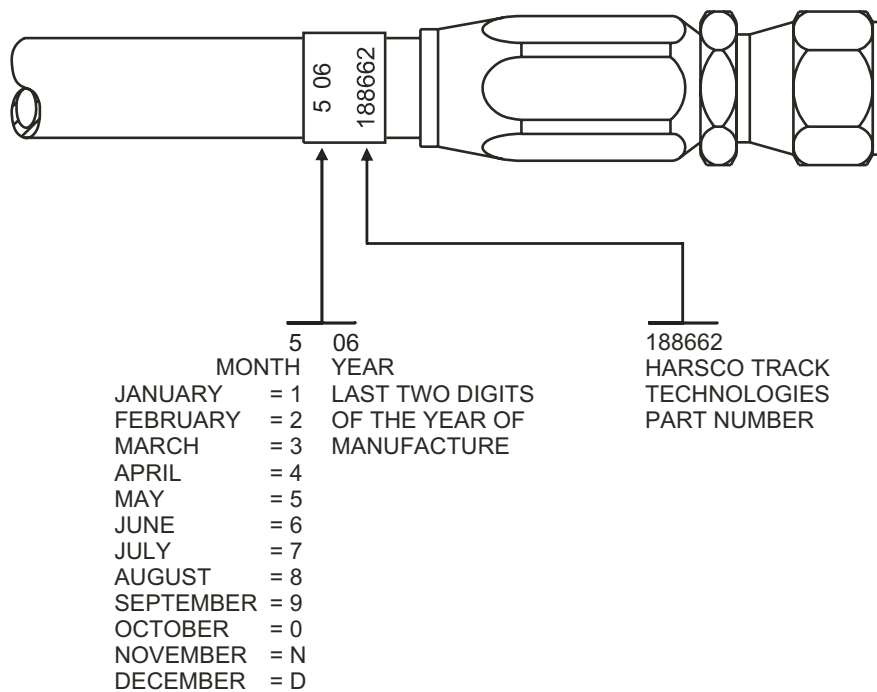

**SECTION 5 - TROUBLESHOOTING  
TABLE OF CONTENTS**

5.1 Troubleshooting Guide Wheel Equipment ..... 5 - 2

**5.1 Troubleshooting Guide Wheel Equipment**

PROBLEM	PROBABLE CAUSE	POSSIBLE REMEDY
Hydraulic pump not delivering oil.	<p>Mechanical PTO not engaged or control valve not shifted to direct oil flow to guide wheel equipment.</p> <p>Switch for auxiliary electric powered hydraulic pump in OFF position.</p> <p>Hydraulic reservoir oil level low.</p> <p>Oil restricted to pump intake.</p> <p>Components bent, broken, worn, etc.</p>	<p>Engage mechanical PTO. Shift control valve to direct oil flow to guide wheel equipment.</p> <p>Move switch to ON position.</p> <p>Fill reservoir to full level with recommended hydraulic oil.</p> <p>Check all strainers and filters for dirt and sludge. Clean and replace if necessary.</p> <p>Replace components.</p>
Guide wheel unit does not lower or raise.	<p>Lock pins engaged.</p> <p>Hydraulic pump not operating.</p> <p>Hydraulic reservoir oil level low.</p> <p>Components bent, broken, worn, etc.</p>	<p>Disengage lock pins. See Operation Section - Placing Vehicle On Track or Removing Vehicle From Track.</p> <p>Start hydraulic pump.</p> <p>Fill reservoir to full level with recommended hydraulic oil.</p> <p>Replace components.</p>
Guide wheel unit is difficult to lower or raise.	<p>Vehicle over-loaded.</p> <p>Components bent, broken, worn, etc.</p>	<p>Remove excess load from vehicle.</p> <p>Replace components.</p>
Lock will not engage when guide wheel unit is in "highway" position.	<p>Components bent, broken, worn, etc.</p>	<p>Replace components.</p>

5

**5.1 Troubleshooting Guide Wheel Equipment**

PROBLEM	PROBABLE CAUSE	POSSIBLE REMEDY
Vehicle load exceeds front Guide wheel unit maximum rated load.	Vehicle overloaded.	Redistribute or remove some of the load.
Vehicle front tires clear rail less than 1-1/2" (38 mm) when vehicle is on track and loaded.	Vehicle overloaded.  Guide wheel unit not adjusted properly.	Redistribute or remove some of the load.  See Adjustment Section - Checking Vehicle Front Tire Clearance - Rail Position.
Vehicle derails.	Guide wheel units, vehicle rear axle, etc. not aligned with vehicle frame.	Check alignment. See Adjustment Section - Guide Wheel Equipment Alignment Procedure.
Vehicle pulls noticeably to the left or right when on track.	Vehicle loaded heavy on one side.  Guide wheel units, vehicle rear axle, etc. not aligned with vehicle frame.  Incorrect or worn vehicle rear tire.  Vehicle rear tires under inflated.  Guide wheel brake shoes dragging.	Move load to center of vehicle.  Check alignment. See Adjustment Section - Guide Wheel Equipment Alignment Procedure.  Check for correct rear tire. Replace if necessary. Replace worn rear tire.  Check pressure. Inflate if low.  Do not exceed tire manufacturer's recommended maximum pressure printed on the sidewalls, or wheel manufacturer's recommended maximum pressure stamped on the wheel, whichever is lower.  Re-adjust brake shoes. See Adjustment Section - Brake Shoe Clearance.

**5.1 Troubleshooting Guide Wheel Equipment**

PROBLEM	PROBABLE CAUSE	POSSIBLE REMEDY
<p>Vibration felt in the vehicle when traveling on track.</p>	<p>Guide wheel units mounting fasteners loose.</p> <p>Guide wheel bearings worn.</p> <p>Guide wheels worn.</p> <p>Vehicle rear rim bent.</p> <p>Vehicle rear tires out of balance.</p>	<p>Tighten all bolts to recommended torque.</p> <p>Replace bearings, wheel or axle.</p> <p>Check guide wheel wear. See Maintenance Section - Guide Wheels, Allowable Wear.</p> <p>Replace. See vehicle manufacturer.</p> <p>Balance tires.</p>
<p><b>5</b> Vibration felt in the vehicle when traveling on highway.</p>	<p>Guide wheel units mounting fasteners loose.</p> <p>Guide wheel units not locked in "highway" position.</p> <p>Vehicle rim bent.</p> <p>Vehicle tires out of balance.</p>	<p>Tighten all bolts to recommended torque.</p> <p>STOP IMMEDIATELY. Make sure both guide wheel units are locked in "highway" position.</p> <p>Replace. See vehicle manufacturer.</p> <p>Balance tires.</p>



**SECTION 6 - PARTS  
TABLE OF CONTENTS**

SERIAL NUMBERS ..... 6 - 2

INSTRUCTIONS FOR ORDERING PARTS ..... 6 - 3

GUIDE WHEEL UNIT - 202600 ..... 6 - 4

GUIDE WHEEL ASSEMBLY..... 6 - 8

STEERING LOCK GROUPS ..... 6 - 8

MANUAL LOCK GROUP - 203174..... 6 - 9

HYDRAULIC LOCK GROUP - 203175..... 6 - 10

RAIL SWEEP GROUP - 203193..... 6 - 12

TRUCK BRAKE CONNECTION - 162114 ..... 6 - 14

HYDRAULIC POWER PACK, FULL - 137926 ..... 6 - 16

HYDRAULIC POWER PACK, ABBREVIATED - 137927 ..... 6 - 20

WHEEL LOAD JACK - 159510..... 6 - 22

SIGHT ROD EXTENSION GROUP - 164574..... 6 - 23

DECAL SERVICE GROUP - 203157 ..... 6 - 23

MOUNTING BRACKET GROUPS

    203214..... 6 - 24

    3409597..... 6 - 24

    3410281..... 6 - 24

**Serial Numbers**

When this bulletin is received, complete the following record from the serial number tag on the front guide wheel unit. Always mention these factory serial numbers when calling or writing about the unit. The serial number tag is located on the frame assembly of the unit.

FRONT GUIDE WHEEL UNIT SERIAL NUMBER

<b>HTT</b> <b>Harsco</b> <b>Track</b> <b>Technologies</b> a harsco company™		PATENT NUMBER <input type="text"/>
WHEN ORDERING PARTS FOR THIS ACCESSORY ALWAYS GIVE THE FOLLOWING INFORMATION		
<b>Fairmont</b> ™ HY-RAIL® GUIDE WHEEL EQUIPMENT		
SERIAL NUMBER <input type="text"/>	SYMBOL <input type="text"/>	MODEL NUMBER <input type="text"/>
FAIRMONT, MN. 56031 U.S.A.		
52400K		

### Instructions For Ordering Parts

1. See Section 7 for the Vehicle Application charts.
2. Find the chart for the make, model and year of the vehicle that the unit is mounted on.
3. Each application consists of required groups, optional groups required and accessory group options. These are the group numbers that were supplied with, or that were available for the unit.
4. Locate the appropriate group numbers in the Parts Section to find the individual parts required.
5. Front - rear and left - right are determined from the operator's position.
6. Assemblies: Items listed in CAPITALS are assemblies which include all parts listed immediately following and indented to the right. When assemblies can be used, always order them to save work of fitting separate parts.
7. For convenience in ordering, parts are listed by item number, part number, description, and quantity in each assembly or group. If in doubt as to any part wanted, send full description, sketch, or send the old part with the order.
8. To insure prompt and correct shipment of parts on orders, always give:
  - a. Quantity of each part wanted.
  - b. Part number of each part as shown in this book. Include any prefix and suffix letters.
  - c. Description of each part as shown in this book.
  - d. Factory serial numbers recorded above.
  - e. Purchase order number (if required).
  - f. Preferred method of shipment.
9. All parts are shipped F.O.B. factory, transportation charges to be paid by customer. Terms to be determined by the Credit Department.

202600 GUIDE WHEEL UNIT

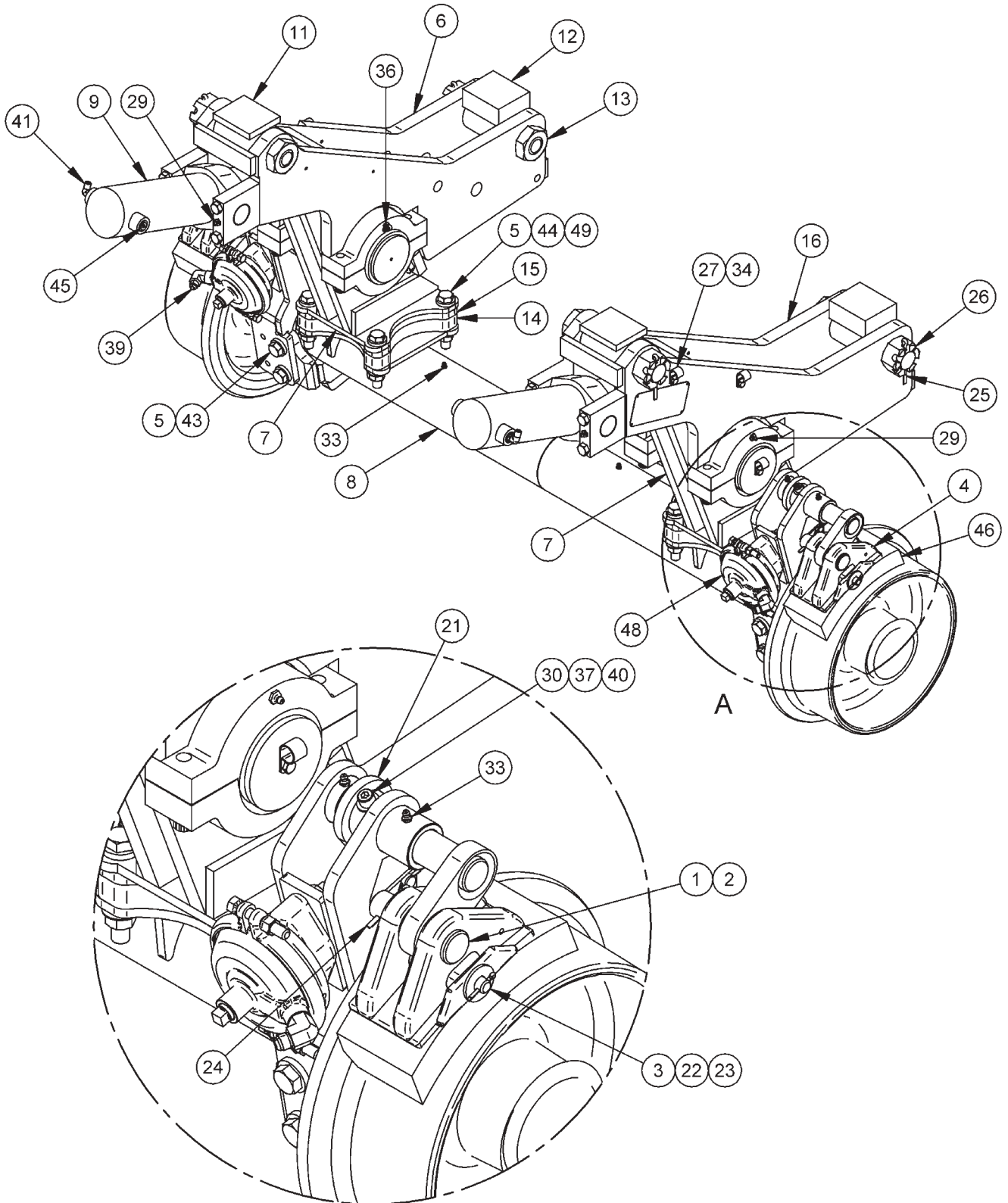

DETAIL A

202600 GUIDE WHEEL UNIT

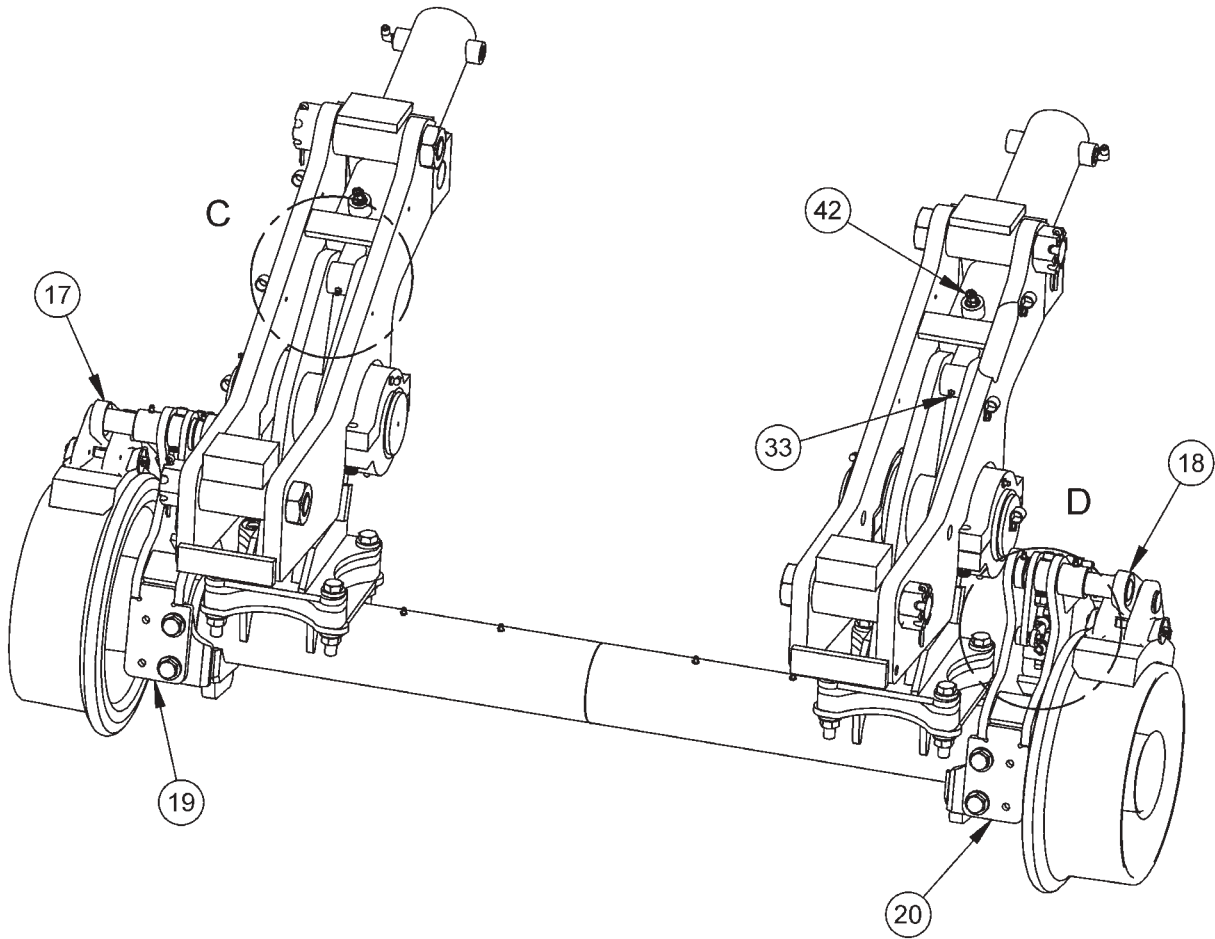

6

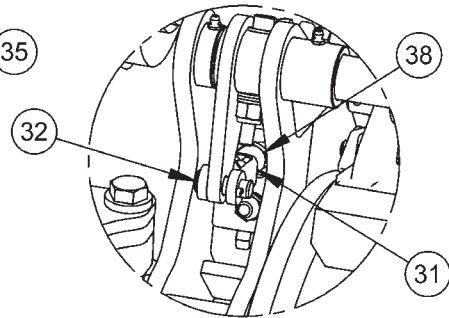
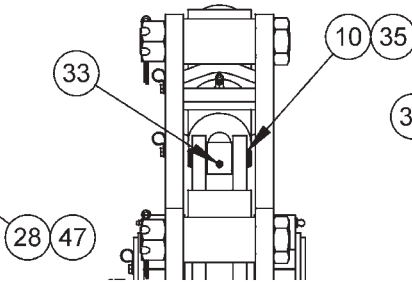
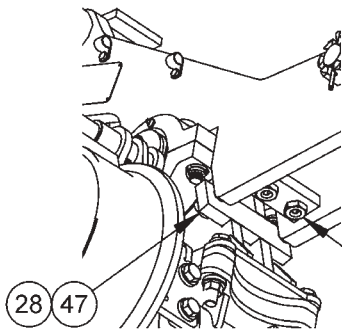

**202600 GUIDE WHEEL UNIT**

ITEM	PART NO	DESCRIPTION	QTY
1	065824	Washer. . . . .	4
2	070238	Pin . . . . .	2
3	126846	Pin . . . . .	2
4	136922K	Brake Shoe Holder. . . . .	2
5	202067	Washer. . . . .	24
6	202576	UPPER STRUCTURE, RIGHT. . . . .	1
	202579	Trunnion Block . . . . .	1
	F021862	Cap Screw, 1/2-13 x 5" Hex Hd . . . . .	4
7	202582	Cross Tube. . . . .	2
8	202598	Axle Assembly (includes slotted nuts and cotter pins) . . . . .	1
9	202599	HYDRAULIC CYLINDER . . . . .	2
	202607	Seal Kit . . . . .	1
10	202609	Pin . . . . .	2
11	202627	Mounting Block, Front . . . . .	2
12	202632	Mounting Block, Rear. . . . .	2
13	202653	Pin . . . . .	4
14	203542	Spacer, 1" . . . . .	2
15	203543	Spacer, 1/2" . . . . .	2
16	203731	UPPER STRUCTURE, LEFT. . . . .	1
	202579	Trunnion Block . . . . .	1
	F021862	Cap Screw, 1/2-13 x 5" Hex Hd . . . . .	4
17	3409092	Brake Arm, Left . . . . .	1
18	3409093	Brake Arm, Right . . . . .	1
19	3409101	Brake Tower, Left. . . . .	1
20	3409102	Brake Tower, Right . . . . .	1
21	3409383	Lever . . . . .	2
22	F001104	Cotter Pin, 1/8 x 1" . . . . .	4
23	F001267	Wrought Washer, 1/2" . . . . .	4
24	F001324	Cotter Pin, 3/16 x 1-1/2" . . . . .	2
25	F001548	Cotter Pin, 1/4 x 3" . . . . .	4
26	F002792	Hex Slotted Nut, 1-1/2" . . . . .	4
27	F003067	Cap Screw, 1/4-20 x 5/8" Hex Hd . . . . .	6
28	F003400	Hex Jam Nut, 3/4-10 GR 2. . . . .	8
29	F004252	Grease Fitting. . . . .	6
30	F004600	Elastic Stop Nut, 3/8"-16 . . . . .	2
31	F005459	Yoke . . . . .	2
32	F005460	Yoke Pin With Cotter Pin . . . . .	2
33	F008014	Grease Fitting. . . . .	10
34	F008430	P-Clamp, 5/8". . . . .	6
35	F009117	Retaining Ring . . . . .	4
36	F009217	Grease Fitting. . . . .	6
37	F009681	SAE Washer, 3/8" . . . . .	8
38	F011013	Hex Jam Nut, 1/2"-20 GR 2 . . . . .	2
39	F012055	90° Elbow, 6 x 6 NPT. . . . .	2

**202600 GUIDE WHEEL UNIT**

ITEM PART NO	DESCRIPTION	QTY
40 F013321	Cap Screw, 3/8-16 x 3-1/4" Soc Hd . . . . .	2
41 F014734	90° Elbow, 4 x 4 SAE . . . . .	2
42 F015106	45° Elbow, 4 x 4 SAE . . . . .	2
43 F019501	Cap Screw, 5/8-11 x 1-3/4" Hex Hd . . . . .	8
44 F021924	Hex Flg Nut, 5/8"-11 GR 5 . . . . .	8
45 F022207	Plug . . . . .	2
46 F022274	Brake Shoe . . . . .	2
47 F023736	Set Screw, 3/4-10 x 1-1/2 Soc Hd Oval Point. . . . .	8
48 F025058	Brake Actuator . . . . .	2
49 F025764	Cap Screw, 5/8-11 x 4" GR 8 . . . . .	8
F018510	Hydraulic Control Valve (not illustrated). . . . .	1

**GUIDE WHEEL ASSEMBLY**

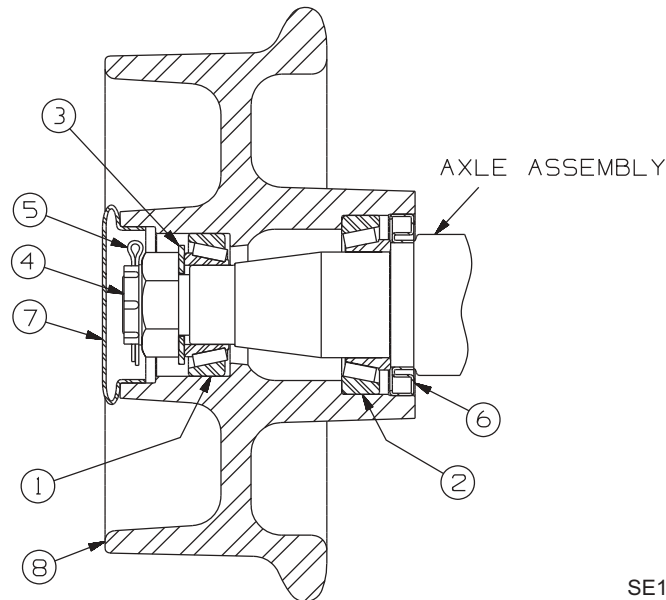

*Note: Quantities listed are for one wheel only.*

ITEM	PART NO	DESCRIPTION	QTY
1	159508	Bearing Cup & Cone, Outside . . . . .	1
2	159507	Bearing Cup & Cone, Inside . . . . .	1
3	F025049	Washer . . . . .	1
4	F025249	Hex Slotted Nut, 1-1/2"-12 (part of axle assembly) . . . . .	1
5	F003150	Cotter Pin, 3/16 x 2-1/2" (part of axle assembly) . . . . .	1
6	F025057	Grease Seal . . . . .	1
7	F025011	Grease Cap . . . . .	1
8	175662	Wheel . . . . .	1

**STEERING LOCK GROUPS**

Individual steering lock components are not available as repair parts. Steering lock groups are sold as complete replacement groups only. See vehicle application charts to find the correct steering lock group applicable to your make, model and year of vehicle.



**203174 MANUAL LOCK GROUP**

ITEM	PART NO	DESCRIPTION	QTY
	203174	MANUAL LOCK GROUP .....	1
1	203185	Pin, Left. ....	1
2	203186	Pin, Right .....	1
3	203189	Angle. ....	4

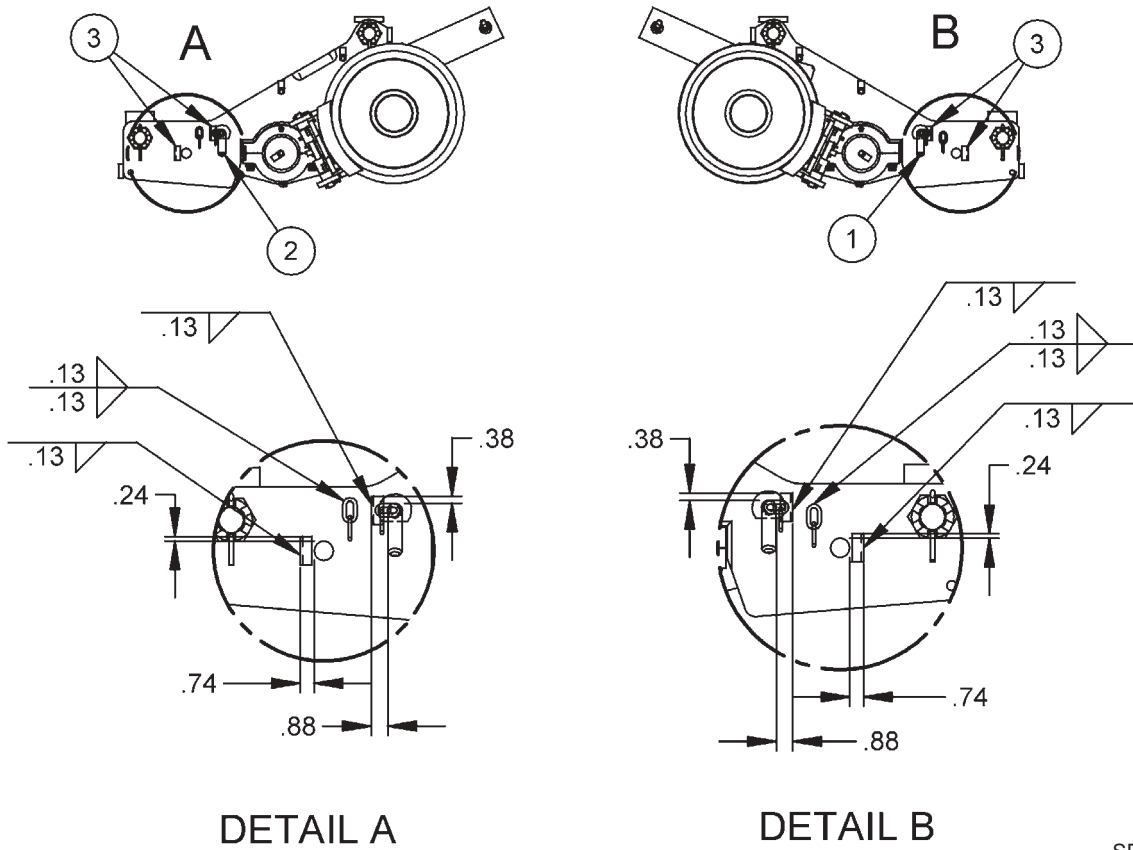

SE203174-C

**203175 HYDRAULIC LOCK GROUP**

ITEM	PART NO	DESCRIPTION	QTY
	203175	HYDRAULIC LOCK GROUP .....	1
1	183744	Hardened Washer, 1" .....	6
2	185380	Cap Screw, 5/16-18 x 2-1/4" GR 8 Hex Hd. ....	2
3	187099	Hydraulic Cylinder. ....	2
4	188894	Cap Screw, 1/2-13 x 7" GR 8 Hex Hd. ....	2
5	202610	Pin .....	2
6	202611	Hook .....	2
7	202612	Spacer .....	2
8	202625	Spacer .....	2
9	F008014	Grease Fitting .....	2
10	F011450	Retaining Ring .....	4
11	F013500	Elastic Stop Nut, 1/2" .....	2
12	F014476	Elastic Stop Nut, 5/16" .....	2
13	F014734	90° Elbow, 4 x 4 SAE .....	4
14	F018615	SAE Washer, 5/16" .....	6
15	F024602	Hardened Washer, 1/2" .....	6

203175 HYDRAULIC LOCK GROUP

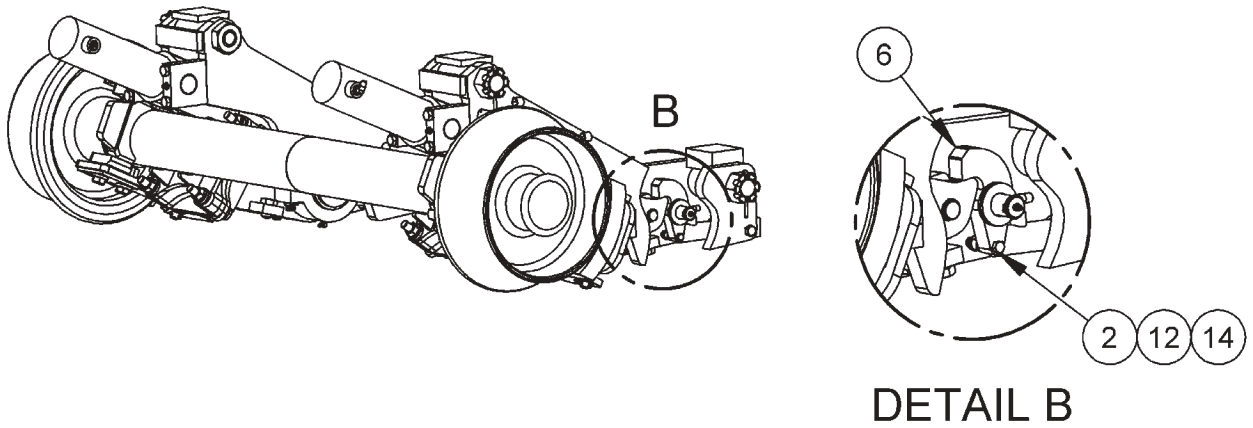
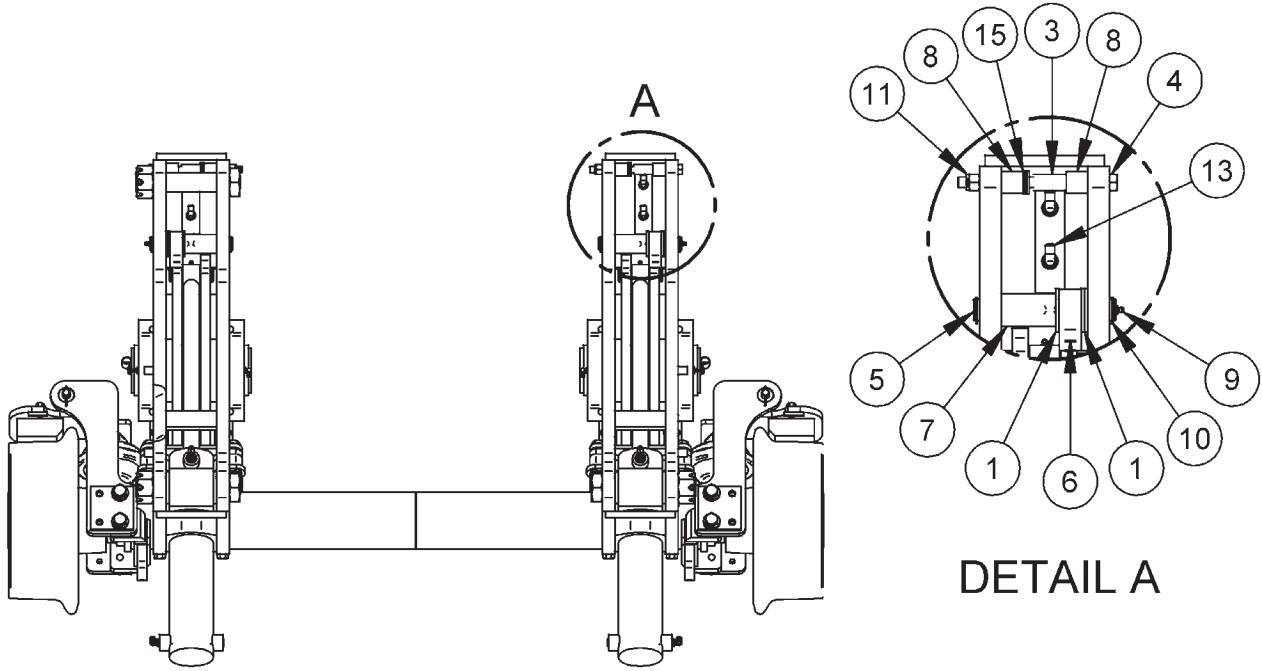

203193 RAIL SWEEP GROUP

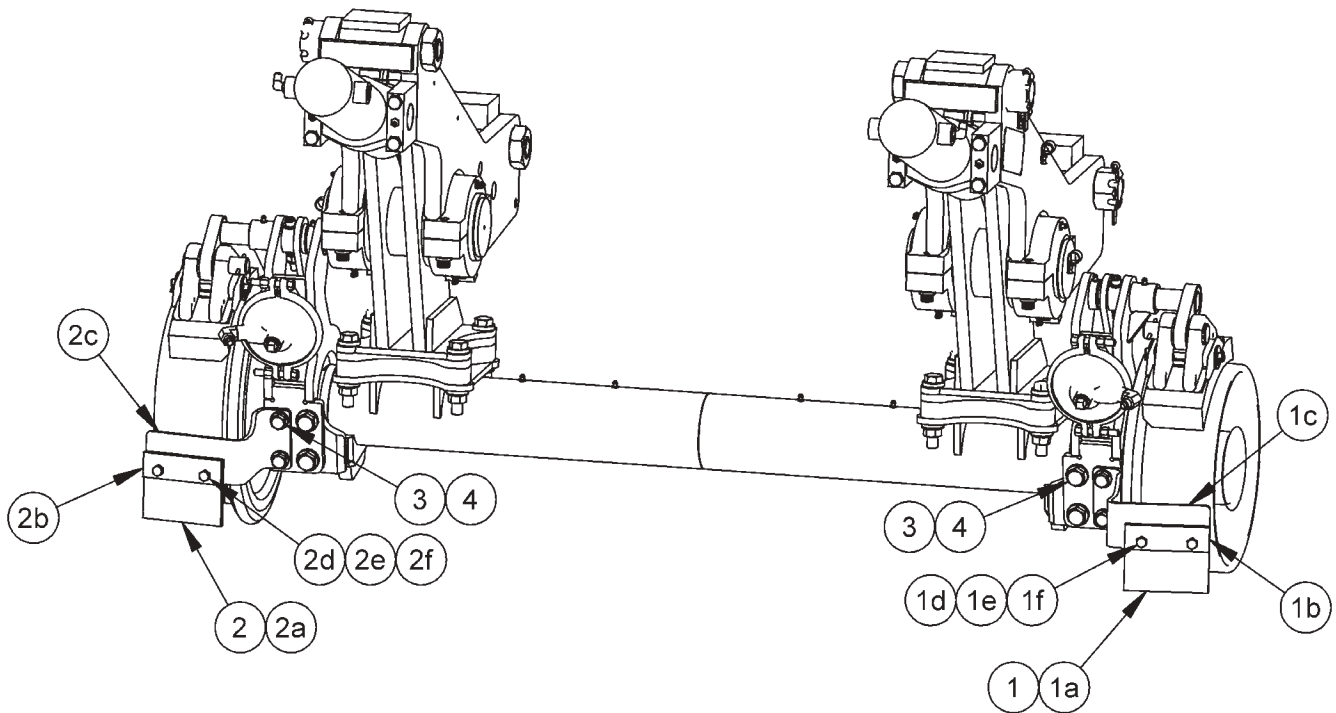

SE203193-C

6

ITEM	PART NO	DESCRIPTION	QTY
	203193	RAIL SWEEP GROUP . . . . .	1
1	203196	RAIL SWEEP ASSEMBLY, LEFT . . . . .	1
1a	108509K1	Rail Sweep . . . . .	1
1b	108510	Rail Sweep Plate. . . . .	1
1c	203194	Rail Sweep Bracket, Left. . . . .	1
1d	202061	Hardened Washer, 3/8" . . . . .	2
1e	F001125	Cap Screw, 3/8-16 x 1-1/4" GR 5 Hex Hd. . . . .	2
1f	F015922	Elastic Stop Nut, 3/8"-16. . . . .	2
2	203197	RAIL SWEEP ASSEMBLY, RIGHT . . . . .	1
2a	108509K1	Rail Sweep . . . . .	1
2b	108510	Rail Sweep Plate. . . . .	1
2c	203195	Rail Sweep Bracket, Right . . . . .	1
2d	202061	Hardened Washer, 3/8" . . . . .	2
2e	F001125	Cap Screw, 3/8-16 x 1-1/4" GR 5 Hex Hd. . . . .	2
2f	F015922	Elastic Stop Nut, 3/8"-16. . . . .	2
3	F018650	Cap Screw, 1/2-13 x 1-1/2" GR 8 Hex Hd . . . . .	4
4	202063	Hardened Washer, 1/2" . . . . .	4



**162114 TRUCK BRAKE CONNECTION**

ITEM	PART NO	DESCRIPTION	QTY
	162114	TRUCK BRAKE CONNECTION.....	1
1	F012055	90° Elbow, 9/16 M JIC x 3/8 M NPT.....	1
2	F018904	Hose, 5/16 x 48" Swivel 9/16 F JIC Both Ends.....	1
3	F012587	Grommet.....	2
4	F010994	Adapter, 9/16 M JIC x 1/4 M NPT.....	1
5	F019332	Air Control Valve.....	1
6	F010989	Pipe Plug, 1/4 M NPT.....	1
7	120453	Bracket.....	1
8	F001113	Cap Screw, 5/16-18 x 1-1/4" Hex Hd.....	2
9	F001100	SAE Lock Washer, 5/16".....	2
10	F007021	Hex Nut, 5/16"-18.....	2
11	122583	Instruction Plate, Rail Wheel.....	1
12	F009591	Machine Screw, #10-24 x 3/4" Rd Hd.....	2
13	F010988	90° Elbow, 9/16 M JIC x 1/4 M NPT.....	1
14	079235	Hose, 5/16 x 51" Swivel 9/16 F JIC Both Ends.....	1
15	F011152	Adapter, 9/16 M JIC x 9/16 M JIC.....	1
16	075540	Hose, 5/16 x 76" Swivel 9/16 F JIC Both Ends.....	1
17	120457	Decal, Rail Brake Operation.....	1

162114 TRUCK BRAKE CONNECTION

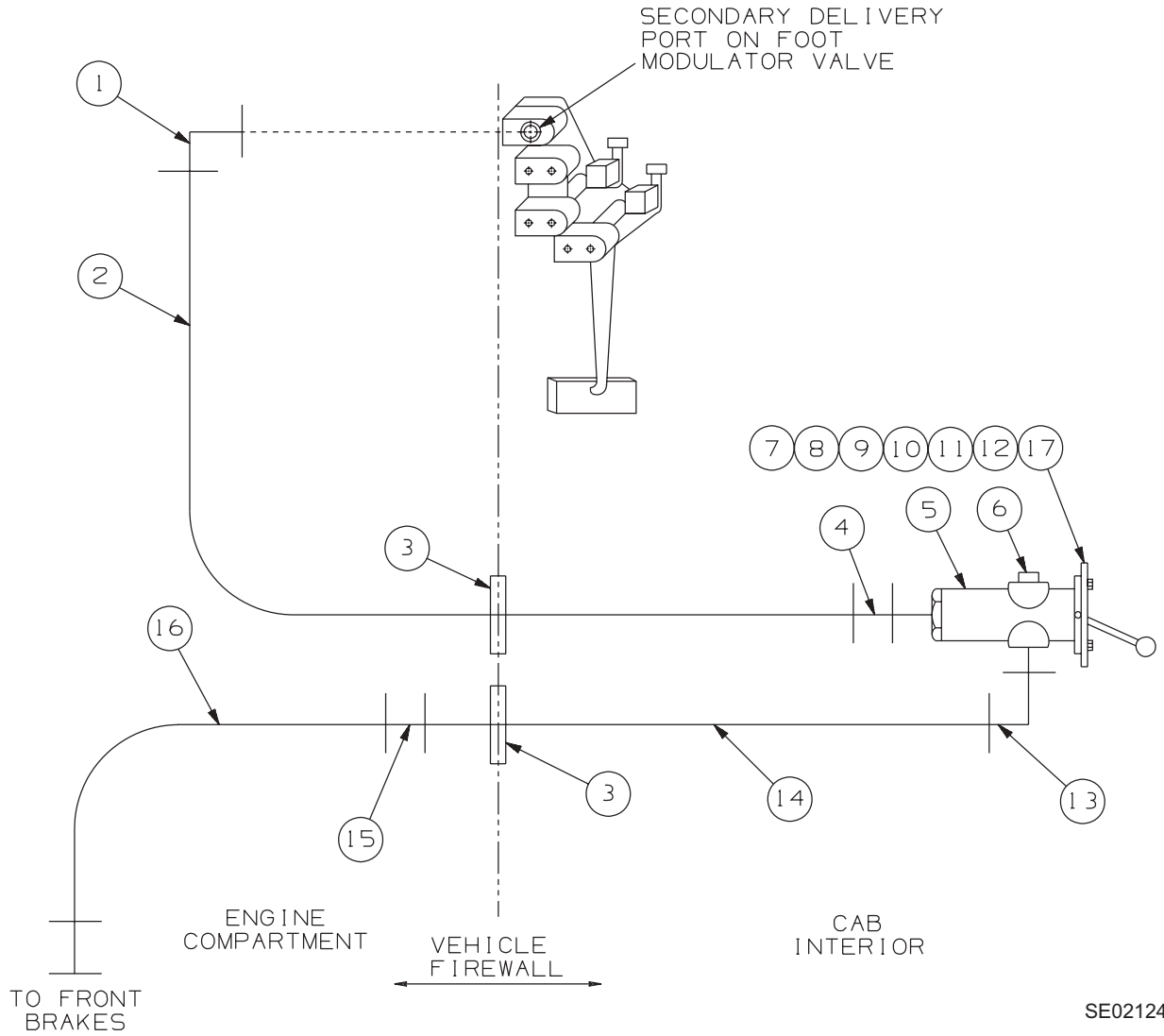

SE0212411-1

137926 HYDRAULIC POWER PACK - FULL

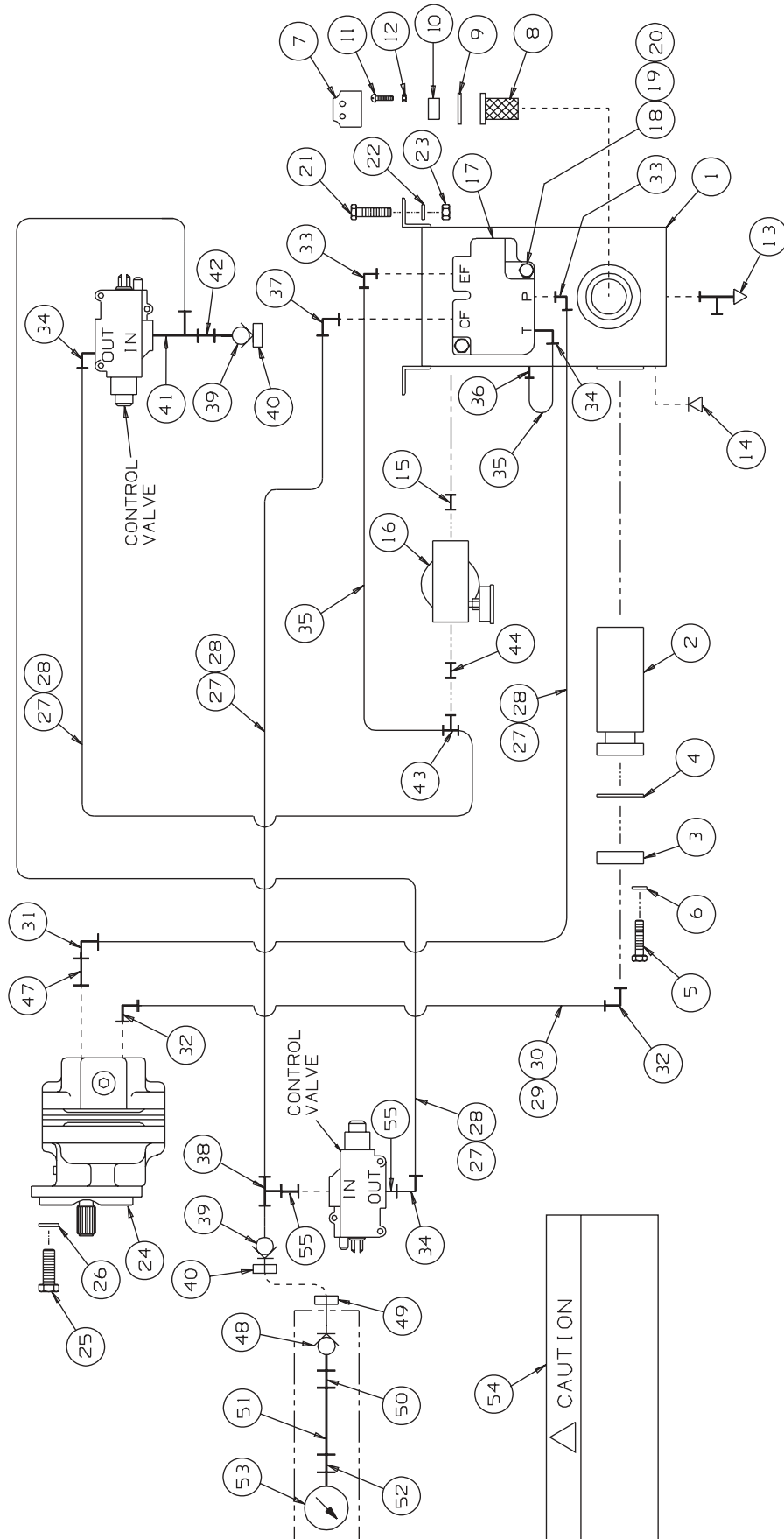

6



**137926 HYDRAULIC POWER PACK - FULL**

ITEM PART NO	DESCRIPTION	QTY
137926	HYDRAULIC POWER PACK -FULL . . . . .	1
129136	HYDRAULIC RESERVOIR ASSEMBLY . . . . .	1
1 099444	Reservoir Only . . . . .	1
2 F014155	Filter . . . . .	1
3 082205	Filter Flange . . . . .	1
4 077997	Flange Gasket . . . . .	1
5 F001125	Cap Screw, 3/8-16 x 1-1/4" Hex Hd. . . . .	4
6 F001025	SAE Lock Washer, 3/8" . . . . .	4
7 F022655	FILLER CAP . . . . .	1
8 F010465	Filler Screen . . . . .	1
9 056780	Filler Flange Gasket . . . . .	2
10 F010466	Filler Flange . . . . .	1
11 F009723	Machine Screw, 10-24 x 3/8" Rd Hd . . . . .	6
12 F009541	SAE Lock Washer, #10 . . . . .	6
13 F010181	Drain Valve, 1/8 M NPT . . . . .	2
14 F012702	Pipe Plug, 3/8 M NPT Magnetic. . . . .	1
15 F001328	Pipe Nipple, 3/4 M NPT x 1-3/8" . . . . .	1
16 F015452	FILTER - RETURN . . . . .	1
16a F015453	Replacement Filter Element . . . . .	1
17 120993	VALVE, FLOW DIVIDER . . . . .	1
17a F019415	Pressure Relief Washers (set of four) . . . . .	1
18 F009663	Cap Screw, 5/16-18 x 2" Hex Hd. . . . .	2
19 F007021	Hex Nut, 5/16"-18 . . . . .	2
20 F001100	SAE Lock Washer, 5/16" . . . . .	2
21 F001125	Cap Screw, 3/8-16 x 1-1/4" Hex Hd . . . . .	4
22 F001025	SAE Lock Washer, 3/8" . . . . .	4
23 F007020	Hex Nut, 3/8"-16 . . . . .	4
24 F023330	Hydraulic Pump . . . . .	1
25 F003136	Cap Screw, 1/2-13 x 1" Hex Hd . . . . .	2
26 F001075	SAE Lock Washer, 1/2" . . . . .	2
140344	HOSE GROUP . . . . .	1
27 F009947	Hose, 13/32 x 960" (cut to length) . . . . .	1
28 F020713	Hose Fitting, Swivel 3/4 F JIC (install on hose F009947) . . . . .	8
29 F010298	Hose, 1-1/8 x 75" (cut to length) . . . . .	1
30 F014307	Hose Fitting, Swivel 1-5/8 F JIC (install on hose F010298) . . . . .	2
31 F013243	90° Elbow, 3/4 M NPT x 3/4 M JIC . . . . .	1
32 F021260	90° Elbow, 1 M NPT x 1-5/8 M JIC . . . . .	2
33 F012054	90° Elbow, 1/2 M NPT x 3/4 M JIC . . . . .	2
34 F011114	90° Elbow, 3/8 M NPT x 3/4 M JIC . . . . .	3
35 067736	Hose, 13/32 x 17" Swivel 3/4 F JIC Both Ends . . . . .	2
36 F011170	Adapter, 3/8 M NPT x 3/4 M JIC . . . . .	1
37 F012704	90° Elbow, 3/4 M JIC x 3/8 M NPT . . . . .	1

**137926 HYDRAULIC POWER PACK - FULL**

ITEM	PART NO	DESCRIPTION	QTY
38	F013605	Tee, 3/4 M JIC x 3/8 M NPT x 3/8 M NPT . . . . .	1
39	F015303K	Nose Piece, 3/8 F NPT . . . . .	2
40	F015077	Dust Cap . . . . .	2
41	F014722	Tee, 3/8 F NPT x 3/4 M JIC x 3/8 M NPT . . . . .	1
42	F011604	Adapter, 3/8 M NPT x 3/8 M NPT . . . . .	1
43	F013629	Tee, 3/4 M JIC x 3/4 M JIC x 3/8 M NPT . . . . .	1
44	F012024	Reducer Bushing, 3/4 M NPT x 3/8 F NPT . . . . .	1
45	Not Used		
47	F011617	Reducer Bushing, 1 M NPT x 3/4 F NPT . . . . .	1
	099137K	PRESSURE GAUGE ASSEMBLY . . . . .	1
48	F015110K	Body, 3/8 F NPT . . . . .	1
49	F015111	Dust Cap . . . . .	1
50	F012056	Adapter, 3/8 M NPT x 9/16 M JIC . . . . .	1
51	171878	Hose, 3/8 x 14" Swivel 9/16 F JIC Both Ends . . . . .	1
52	F011109	Adapter, 9/16 M JIC x 1/4 F NPT . . . . .	1
53	F011432K	Pressure Gauge, 1/4 M NPT . . . . .	1
54	137941	Decal, Caution -Recommended... . . . . .	1
55	F015103	Adapter, 3/8 F NPT x 3/4 M STR . . . . .	2

NOTES

Lined area for notes, consisting of multiple horizontal lines.

137927 HYDRAULIC POWER PACK - ABBREVIATED

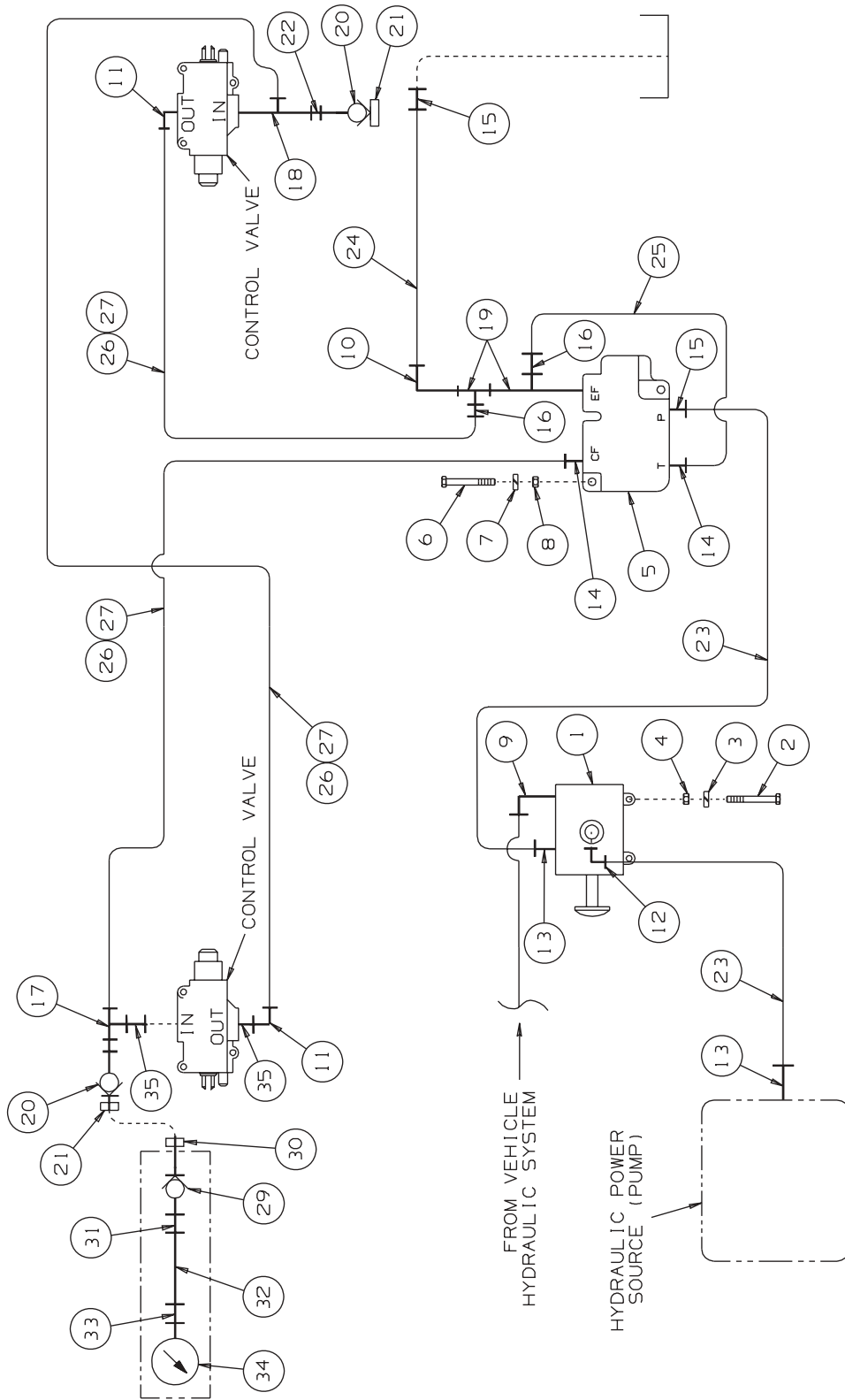

**137927 HYDRAULIC POWER PACK - ABBREVIATED**

ITEM	PART NO	DESCRIPTION	QTY
	137927	HYDRAULIC POWER PACK -ABBREVIATED . . . . .	1
1	F016490	Selector Valve. . . . .	1
2	F002760	Cap Screw, 3/8-16 x 2-1/4" Hex Hd . . . . .	2
3	F001025	SAE Lock Washer, 3/8" . . . . .	2
4	F009670	Hex Grip Nut, 3/8"-16. . . . .	2
5	120993	VALVE, FLOW DIVIDER . . . . .	1
	F019415	Pressure Relief Washers (set of four) . . . . .	1
6	F009663	Cap Screw, 5/16-18 x 2" Hex Hd . . . . .	2
7	F001100	SAE Lock Washer, 5/16" . . . . .	2
8	F007021	Hex Nut, 5/16"-18 . . . . .	2
9	F012010	90° Elbow Street, 3/4 F NPT x 3/4 M NPT . . . . .	1
10	F010584	90° Elbow, 1-1/16 M JIC x 1/2 M NPT . . . . .	1
11	F011114	90° Elbow, 3/4 M JIC x 3/8 M NPT . . . . .	2
12	F010586	90° Elbow, 1-1/16 M JIC x 3/4 M NPT . . . . .	1
13	F010581	Adapter, 1-1/16 M JIC x 3/4 M NPT . . . . .	2
14	F011170	Adapter, 3/4 M JIC x 3/8 M NPT . . . . .	2
15	F013210	Adapter, 1-1/16 M JIC x 1/2 M NPT . . . . .	2
16	F012027	Adapter, 3/4 M JIC x 1/2 M NPT . . . . .	2
17	F013605	Tee, 3/4 M JIC x 3/8 M NPT x 3/8 M NPT. . . . .	1
18	F014722	Tee, 3/8 F NPT x 3/4 M JIC x 3/8 M NPT . . . . .	1
19	F010692	Tee, 1/2 F NPT x 1/2 M NPT x 1/2 F NPT . . . . .	2
20	F015303K	Nose Piece, 3/8 F NPT . . . . .	2
21	F015077	Dust Cap. . . . .	2
22	F011604	Adapter, 3/8 M NPT x 3/8 M NPT . . . . .	1
23	071692	Hose, 5/16 x 48" Swivel 1-1/16 F JIC Both Ends . . . . .	2
24	111100	Hose, 3/4 x 28" Swivel 1-1/16 F JIC Both Ends . . . . .	1
25	071867	Hose, 1/2 x 19-3/4" Swivel 3/4 F JIC Both Ends. . . . .	1
	140345	HOSE GROUP . . . . .	1
26	F009947	Hose, 13/32 x 960" (cut to length) . . . . .	1
27	F020713	Hose Fitting, Swivel 3/4 F JIC (install on hose F009947) . . . . .	6
	099137K	PRESSURE GAUGE ASSEMBLY. . . . .	1
29	F015110K	Body, 3/8 F NPT. . . . .	1
30	F015111	Dust Cap . . . . .	1
31	F012056	Adapter, 3/8 M NPT x 9/16 M JIC . . . . .	1
32	171878	Hose, 3/8 x 14" Swivel 9/16 F JIC Both Ends . . . . .	1
33	F011109	Adapter, 9/16 M JIC x 1/4 F NPT . . . . .	1
34	F011432K	Pressure Gauge, 1/4 M NPT . . . . .	1
35	F015103	Adapter, 3/8 F NPT x 3/4 M STR . . . . .	2

**159510 WHEEL LOAD JACK GROUP**

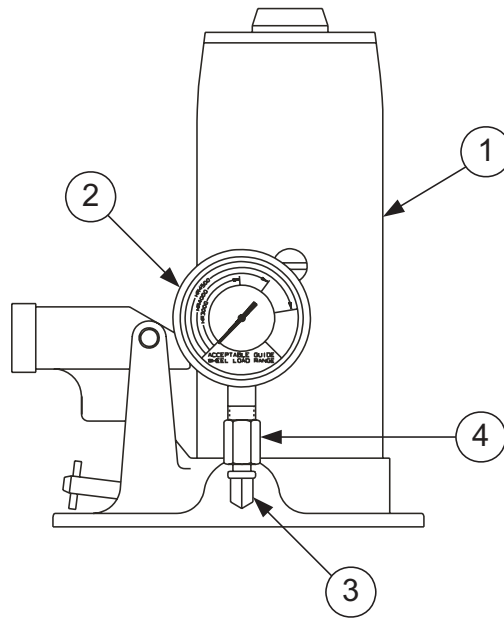

SE021048

ITEM	PART NO	DESCRIPTION	QTY
	159510	WHEEL LOAD JACK GROUP .....	1
1	F025272	Hydraulic Jack .....	1
2	159512	Gauge Assembly with Decals .....	1
3	146353	90° Elbow, 1/4 F NPT x 1/4 M NPT .....	1
4	F023088	Adapter, 1/4 F NPT x 1/4 M NPT .....	1

**164574 SIGHT ROD EXTENSION GROUP**

PART NO	DESCRIPTION	QTY
164574	SIGHT ROD EXTENSION GROUP .....	1
130195	Sight Rod Kit (includes two sight rods) .....	1
135809	Sight Rod Extension .....	2
161855	Mounting Bar .....	2
F022036	Cap Screw, 1/2-13 x 1-1/4" Hex Flg Hd .....	2
F022037	Hex Flg Nut, 1/2"-13 .....	2

**203157 DECAL SERVICE GROUP**

PART NO	DESCRIPTION	QTY
203157	DECAL SERVICE GROUP .....	1
F018082	Decal, Safety Instructions: Lock Front Wheels... ..	1
140220	Decal, Warning: Do Not Operate.... ..	2
155007	Decal, HY-RAIL® Vehicle Completed By... ..	1
191761	Decal, Harsco Track Technologies .....	2
201564	Decal, Control Valve Operating Instructions .....	1
201565	Decal, Operating Instructions .....	1
201567	Decal, Operating Instructions .....	1
3410748	Decal, Operating Instructions .....	1

**203214 MOUNTING BRACKET GROUP**

PART NO	DESCRIPTION	QTY
203214	MOUNTING BRACKET GROUP . . . . .	1
203204	Mounting Bracket . . . . .	2
202631	Shim, 1/2" . . . . .	2
202635	Rod Assembly . . . . .	2
202638	Shim, 1/2" . . . . .	2
202639	Shim, 1" . . . . .	8
202640	Pad . . . . .	2
202643	Shim, 1" . . . . .	10
F013695	Hex Nut, 3/4"-10 GR 5 . . . . .	8
024626	Front Unit Application Drawing	

**3409597 MOUNTING BRACKET GROUP**

PART NO	DESCRIPTION	QTY
3409597	MOUNTING BRACKET GROUP . . . . .	1
202631	Shim, 1/2" . . . . .	2
202635	Rod Assembly . . . . .	2
202638	Shim, 1/2" . . . . .	2
202639	Shim, 1" . . . . .	8
202640	Pad . . . . .	2
202643	Shim, 1" . . . . .	2
203204	Mounting Bracket . . . . .	2
F013695	Hex Nut, 3/4"-10 GR 5 . . . . .	8

**3410281 MOUNTING BRACKET GROUP**

PART NO	DESCRIPTION	QTY
3410281	MOUNTING BRACKET GROUP . . . . .	1
202631	Shim, 1/2" . . . . .	2
202635	Rod Assembly . . . . .	2
202638	Shim, 1/2" . . . . .	2
202639	Shim, 1" . . . . .	6
202640	Pad . . . . .	2
3410276	Left Side Bar . . . . .	1
3410277	Right Side Bar . . . . .	1
3410305	Bar . . . . .	2
F013500	Elastic Stop Nut, 1/2 -13. . . . .	12
F013695	Hex Nut, 3/4"-10 GR 5 . . . . .	8
F018861	Cap Screw, 1/2-13 x 2-1/4" Hex Hd . . . . .	12
F024047	Washer. . . . .	24



**SECTION 7 - VEHICLE APPLICATIONS**  
**TABLE OF CONTENTS**

2004 FREIGHTLINER .....	7 - 2
2006 INTERNATIONAL .....	7 - 2
2007 INTERNATIONAL .....	7 - 3

2004 FREIGHTLINER M-2 106V 12,000 GAWR - FRONT HR3000C2 FRONT HR3000B1 REAR	2006 INTERNATIONAL 4300 SERIES 12,000 GAWR - FRONT HR3000C2 FRONT HR3000B1 REAR
---	---

REQUIRED GROUPS

Guide Wheel Unit Application . . . . .	203259 . . . . .	203259
Front Guide Wheel Unit . . . . .	202600 . . . . .	202600
Mounting Brackets . . . . .	203214 . . . . .	3409597
Lock Group (one required)		
Manual Lock . . . . .	203174 . . . . .	203174
Application Drawing . . . . .	024607 . . . . .	024607
Hydraulic Lock . . . . .	203175 . . . . .	203175
Application Drawing . . . . .	024608 . . . . .	024608
Steering Lock . . . . .	202549 . . . . .	201711
Application Drawing - Front . . . . .	024626 . . . . .	_____

ACCESSORY GROUP OPTIONS

Hydraulic Power Pack - Full . . . . .	137926 . . . . .	137926
Hydraulic Power Pack - Abbreviated . . . . .	137927 . . . . .	137927
Truck Brake Connection . . . . .	162114 . . . . .	162114
* Rail Sweeps - Front . . . . .	203193 . . . . .	203193
Wheel Load Jack . . . . .	159510 . . . . .	159510
Sight Rod Kit And Extension . . . . .	164574 . . . . .	164574

\* Recommended Safety Option

2007 INTERNATIONAL 4200 SERIES 12,000 GAWR - FRONT HR3000C2 FRONT HR3000A1 REAR	2007 INTERNATIONAL 3300 CE SERIES 12,000 GAWR - FRONT HR3000C2 FRONT HR3000A1 REAR
---	--

REQUIRED GROUPS

Guide Wheel Unit Application . . . . .	3410311 . . . . .	3410311
Front Guide Wheel Unit . . . . .	202600 . . . . .	202600
Mounting Brackets . . . . .	3410281 . . . . .	3410281
Lock Group (one required)		
Manual Lock . . . . .	203174 . . . . .	203174
Application Drawing . . . . .	024607 . . . . .	024607
Hydraulic Lock . . . . .	203175 . . . . .	203175
Application Drawing . . . . .	024608 . . . . .	024608
Steering Lock . . . . .	201711 . . . . .	201711

ACCESSORY GROUP OPTIONS

Hydraulic Power Pack - Full . . . . .	137926 . . . . .	137926
Hydraulic Power Pack - Abbreviated . . . . .	137927 . . . . .	137927
Truck Brake Connection . . . . .	162114 . . . . .	162114
* Rail Sweeps - Front . . . . .	203193 . . . . .	203193
Wheel Load Jack . . . . .	159510 . . . . .	159510
Sight Rod Kit And Extension . . . . .	164574 . . . . .	164574

\* Recommended Safety Option



**APPENDIX A - CONVERSION TABLES**  
**TABLE OF CONTENTS**



BOLT TORQUE REQUIREMENTS - STANDARD TYPE FASTENERS..... A - 2  
BOLT TORQUE REQUIREMENTS - SERRATED TYPE FLANGE FASTENERS .... A - 3  
BOLT TORQUE REQUIREMENTS - METRIC TYPE FASTENERS..... A - 4  
INCH TO MILLIMETERS ..... A - 6  
FEET TO METERS..... A - 6  
POUNDS TO KILOGRAMS ..... A - 7  
POUNDS PER SQUARE INCH TO BAR ..... A - 7  
POUNDS PER SQUARE INCH TO KILOPASCALS..... A - 7  
FAHRENHEIT TO CELSIUS (Centigrade) ..... A - 8  
MILES PER HOUR TO KILOMETERS PER HOUR..... A - 9  
GALLONS TO LITERS..... A - 9

**Appendix A**

**FIGURE A-1  
STANDARD BOLT TORQUE REQUIREMENTS TABLE  
STANDARD TYPE FASTENERS**

The torque values listed below are for standard-type fasteners only. The torque values listed are based on wet and (lubricated) dry conditions. The torque values for 1/4 and 5/16 inch size fasteners are listed in lb-in and N-m torque equivalents. The torque values for all other size fasteners are listed lb-ft and N-m torque equivalents. Use lower grade torque values if bolt and nut have different SAE grades. Manufacturer's SAE grade markings may vary.

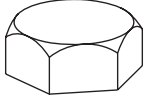
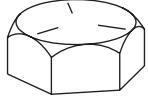
**STANDARD MARKINGS AND TORQUE SPECIFICATIONS**

SAE Grade	1 or 2				5				8			
Fastener Standard SAE Grade Markings												
Fastener Body Size Inch-Thread	Torque				Torque				Torque			
	Wet		Dry		Wet		Dry		Wet		Dry	
	lb-in	N-m	lb-in	N-m	lb-in	N-m	lb-in	N-m	lb-in	N-m	lb-in	N-m
1/4 - 20	49	5.5	65	7.3	75	8.5	100	11.3	107	12.0	142	16.0
1/4 - 28	56	6.5	74	8.3	86	9.7	114	12.8	122	13.8	162	18.3
5/16 - 18	103	11.6	137	15.5	157	17.7	208	23.5	220	24.8	293	33.1
5/16 - 24	113	12.7	150	16.9	173	19.5	230	25.9	244	27.5	325	36.7
Fastener Body Size Inch-Thread	Torque				Torque				Torque			
	Wet		Dry		Wet		Dry		Wet		Dry	
	lb-ft	N-m	lb-ft	N-m	lb-ft	N-m	lb-ft	N-m	lb-ft	N-m	lb-ft	N-m
3/8 - 16	15	20	20	27	23	31	31	42	32	43	43	58
3/8 - 24	17	23	23	31	26	35	35	47	37	50	49	66
7/16 - 14	24	32	32	43	37	50	49	66	52	70	69	93
7/16 - 20	27	36	36	49	42	57	56	76	58	78	77	104
1/2 - 13	39	53	52	70	57	77	76	103	80	108	106	144
1/2 - 20	41	55	55	74	64	87	85	115	90	122	120	163
9/16 - 12	53	72	71	96	82	111	109	148	115	156	153	207
9/16 - 18	59	80	78	106	91	123	121	164	129	175	172	233
5/8 - 11	73	99	97	131	113	155	150	203	160	217	213	289
5/8 - 18	83	112	110	149	128	173	170	230	180	244	239	324
3/4 - 10	129	175	172	233	200	271	266	361	282	382	375	508
3/4 - 16	144	195	192	260	223	302	297	403	315	427	419	568
7/8 - 9	124	168	165	224	323	438	430	583	454	615	604	819
7/8 - 14	138	187	184	249	355	481	472	640	501	679	666	903
1 - 8	188	255	250	339	483	655	642	870	681	923	906	1228
1 - 14	210	285	279	378	541	733	720	976	764	1036	1016	1377
1-1/8 - 7	266	361	354	480	596	808	793	1075	966	1310	1285	1742
1-1/8 - 12	297	403	395	535	668	906	888	1204	1083	1468	1440	1952
1-1/4 - 7	375	508	499	676	841	1140	1119	1517	1363	1848	1813	2458
1-1/4 - 12	415	563	552	748	930	1261	1237	1677	1509	2046	2007	2721
1-3/8 - 6	492	667	654	887	1102	1494	1466	1988	1787	2423	2377	3223
1-3/8 - 12	560	759	745	1010	1255	1701	1670	2264	2034	2758	2705	3667
1-1/2 - 6	653	885	868	1177	1463	1983	1946	2638	2371	3215	3153	4275
1-1/2 - 12	734	995	976	1323	1645	2230	2188	2966	2668	3617	3548	4810

**A**

**Appendix A**

**FIGURE A-2  
STANDARD BOLT TORQUE REQUIREMENTS TABLE  
SERRATED TYPE FLANGE FASTENERS**

The torque values listed below are for serrated-type flange fasteners only. The torque values listed are based on wet (lubricated) and dry conditions. The torque values for all other size fasteners are listed in lb-ft and N-m torque equivalents. Use lower grade torque values if bolt and nut have different SAE grades. Manufacturer's SAE grade markings may vary.

**STANDARD MARKINGS AND TORQUE SPECIFICATIONS**

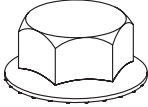
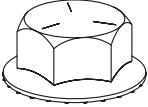
SAE Grade	1 or 2				5			
Fastener Standard SAE Grade Markings								
Fastener Body Size Inch-Thread	Torque				Torque			
	Wet		Dry		Wet		Dry	
	lb-ft	N-m	lb-ft	N-m	lb-ft	N-m	lb-ft	N-m
1/4 - 20	8	10.8	11	14.9	11	14.9	15	20.3
1/4 - 28	9	12.2	12	16.3	12	16.3	16	21.7
5/16 - 18	13	17.6	17	23.0	20	27.1	27	36.6
5/16 - 24	13	17.6	17	23.0	32	43.3	43	58.3
3/8 - 16	23	31	31	42	40	54	53	72
3/8 - 24	25	34	33	45	43	58	57	77
7/16 - 14	38	51	51	69	55	74	73	99
7/16 - 20	40	54	53	72	60	81	80	108
1/2 - 13	60	81	80	108	95	129	127	172
1/2 - 20	65	88	87	118	100	135	133	180
9/16 - 12	78	106	104	141	140	190	187	253
9/16 - 18	85	115	113	153	150	203	200	271
5/8 - 11	125	169	167	226	190	258	253	343
5/8 - 18	135	183	180	244	220	298	293	397
3/4 - 10	225	305	300	407	350	474	467	633
3/4 - 16	250	339	333	451	400	542	533	723
7/8 - 9	350	474	467	633	550	746	733	994
7/8 - 14	375	508	500	678	600	813	800	1085
1 - 8	480	651	640	868	750	1017	1000	1356
1 - 14	500	678	666	903	800	1085	1066	1445



**Appendix A**

**FIGURE A-3  
BOLT TORQUE REQUIREMENTS TABLE  
METRIC TYPE FASTENERS**

Do not use these values if a different torque value or tightening procedure is given for a specific application. Torque values listed are for general use only. Check tightness of fasteners periodically. Fasteners should be replaced with the same or higher property class. If higher property class fasteners are used, these should only be tightened to the strength of the original. Make sure fastener's threads are clean and that thread engagement is properly started. This will help prevent them from failing when tightening.

\*Lubricated means coated with a lubricant such as engine oil, or fasteners with phosphate and oil coatings. Dry means plain or zinc plated without any lubrication.

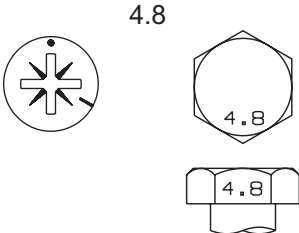
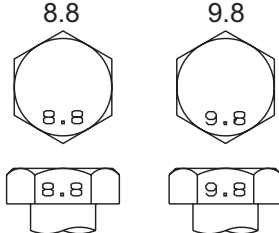
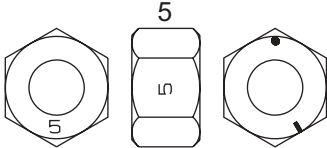
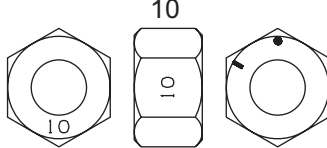
Property Class and Head Markings								
Property Class and Head Markings								
Size	Class 4.8				Class 8.8 or 9.8			
	* Lubricated		* Dry		* Lubricated		* Dry	
	N - m	lb - ft	N - m	lb - ft	N - m	lb - ft	N - m	lb - ft
M 6	4.8	3.5	6	4.5	9	6.5	11	8.5
M 8	12	8.5	15	11	22	16	28	20
M10	23	17	29	21	43	32	55	40
M12	40	29	50	37	75	55	95	70
M14	63	47	80	60	120	88	150	110
M16	100	73	125	92	190	140	240	175
M18	135	100	175	125	260	195	330	250
M20	190	140	240	180	375	275	475	350
M22	260	190	330	250	510	375	650	475
M24	330	250	425	310	650	475	825	600
M27	490	360	625	450	950	700	1200	875
M30	675	490	850	625	1300	950	1650	1200
M33	900	675	1150	850	1750	1300	2200	1650
M36	1150	850	1450	1075	2250	1650	2850	2100

**A**



**Appendix A**

**FIGURE A-4  
BOLT TORQUE REQUIREMENTS TABLE  
METRIC TYPE FASTENERS**

Do not use these values if a different torque value or tightening procedure is given for a specific application. Torque values listed are for general use only. Check tightness of fasteners periodically. Fasteners should be replaced with the same or higher property class. If higher property class fasteners are used, these should only be tightened to the strength of the original. Make sure fastener's threads are clean and that thread engagement is properly started. This will help prevent them from failing when tightening.

\*Lubricated means coated with a lubricant such as engine oil, or fasteners with phosphate and oil coatings. Dry means plain or zinc plated without any lubrication.

Property Class and Head Markings								
Size	Class 10.9				Class 12.9			
	* Lubricated		* Dry		* Lubricated		* Dry	
	N - m	lb - ft	N - m	lb - ft	N - m	lb - ft	N - m	lb - ft
M 6	13	9.5	17	12	15	11.5	19	14.5
M 8	32	24	40	30	37	28	47	35
M10	63	47	80	60	75	55	95	70
M12	110	80	140	105	130	95	165	120
M14	175	130	225	165	205	150	260	190
M16	275	200	350	255	320	240	400	300
M18	375	275	475	350	440	325	560	410
M20	530	400	675	500	625	460	800	580
M22	725	540	925	675	850	625	1075	800
M24	925	675	1150	850	1075	800	1350	1000
M27	1350	1000	1700	1250	1600	1150	2000	1500
M30	1850	1350	2300	1700	2150	1600	2700	2000
M33	2500	1850	3150	2350	2900	2150	3700	2750
M36	3200	2350	4050	3000	3750	2750	4750	3500

**A**

**Appendix A**

**FIGURE A-5  
INCH TO MILLIMETER CONVERSION TABLE  
1 INCH = 25.4 MILLIMETERS**

FRACTIONS	DECIMALS	MILLIMETERS	FRACTIONS	DECIMALS	MILLIMETERS
1/64	.016	0.397	33/64	.516	13.097
1/32	.031	0.794	17/32	.531	13.494
3/64	.047	1.191	35/64	.547	13.891
1/16	.063	1.588	9/16	.563	14.288
5/64	.078	1.984	37/64	.578	14.684
3/32	.094	2.381	19/32	.594	15.081
7/64	.109	2.778	39/64	.609	15.478
1/8	.125	3.175	5/8	.625	15.875
9/64	.141	3.572	41/64	.641	16.272
5/32	.156	3.969	21/32	.656	16.669
11/64	.172	4.366	43/64	.672	17.066
3/16	.188	4.763	11/16	.688	17.463
13/64	.203	5.159	45/64	.703	17.859
7/32	.219	5.556	23/32	.719	18.256
15/64	.234	5.953	47/64	.734	18.653
1/4	.250	6.350	3/4	.750	19.050
17/64	.266	6.747	49/64	.766	19.447
9/32	.281	7.144	25/32	.781	19.844
19/64	.297	7.541	51/64	.797	20.241
5/16	.313	7.938	13/16	.813	20.638
21/64	.328	8.334	53/64	.828	21.034
11/32	.344	8.731	27/32	.844	21.431
23/64	.359	9.128	55/64	.859	21.828
3/8	.375	9.525	7/8	.875	22.225
25/64	.391	9.922	57/64	.891	22.622
13/32	.406	10.319	29/32	.906	23.019
27/64	.422	10.716	59/64	.922	23.416
7/16	.438	11.113	15/16	.938	23.813
29/64	.453	11.509	61/64	.953	24.209
15/32	.469	11.906	31/32	.969	24.606
31/64	.484	12.303	63/64	.984	25.003
1/2	.500	12.700	1	1.000	25.400

**FIGURE A-6  
FEET TO METERS CONVERSION TABLE  
1 FOOT = 0.3048 METER**

FEET	METERS	FEET	METERS	FEET	METERS	FEET	METERS	FEET	METERS
100	30.480	10	3.048	1	0.305	0.1	0.030	0.01	0.003
200	60.960	20	6.096	2	0.610	0.2	0.061	0.02	0.006
300	91.440	30	9.144	3	0.914	0.3	0.091	0.03	0.009
400	121.920	40	12.192	4	1.219	0.4	0.122	0.04	0.012
500	152.400	50	15.240	5	1.524	0.5	0.152	0.05	0.015
600	182.880	60	18.288	6	1.829	0.6	0.183	0.06	0.018
700	213.360	70	21.336	7	2.134	0.7	0.213	0.07	0.021
800	243.840	80	24.384	8	2.438	0.8	0.244	0.08	0.024
900	274.320	90	27.432	9	2.743	0.9	0.274	0.09	0.027
1,000	304.800	100	30.480	10	3.048	1.0	0.305	0.10	0.030

**A**

**Appendix A**

**FIGURE A-7  
POUNDS TO KILOGRAMS CONVERSION TABLE  
1 POUND = 0.4536 KILOGRAM**

LB	KG	LB	KG	LB	KG	LB	KG	LB	KG
1,000	453.59	100	45.36	10	4.54	1	0.45	0.1	0.05
2,000	907.18	200	90.72	20	9.07	2	0.91	0.2	0.09
3,000	1,360.78	300	136.08	30	13.61	3	1.36	0.3	0.14
4,000	1,814.37	400	181.44	40	18.14	4	1.81	0.4	0.18
5,000	2,267.96	500	226.80	50	22.68	5	2.27	0.5	0.23
6,000	2,721.55	600	272.16	60	27.22	6	2.72	0.6	0.27
7,000	3,175.15	700	317.51	70	31.75	7	3.18	0.7	0.32
8,000	3,628.74	800	362.87	80	36.29	8	3.63	0.8	0.36
9,000	4,082.33	900	408.23	90	40.82	9	4.08	0.9	0.41
10,000	4,535.92	1,000	453.59	100	45.36	10	4.54	1.0	0.45

**FIGURE A-8  
POUNDS PER SQUARE INCH TO BAR CONVERSION TABLE  
1 PSI = 0.06895 BAR**

PSI	BAR	PSI	BAR	PSI	BAR	PSI	BAR
1,000	68.95	100	6.90	10	0.69	1	0.07
2,000	137.90	200	13.79	20	1.38	2	0.14
3,000	206.84	300	20.68	30	2.07	3	0.21
4,000	275.80	400	27.58	40	2.76	4	0.28
5,000	344.70	500	34.47	50	3.45	5	0.35
6,000	413.64	600	41.36	60	4.14	6	0.41
7,000	482.58	700	48.26	70	4.83	7	0.48
8,000	551.52	800	55.15	80	5.52	8	0.55
9,000	620.46	900	62.05	90	6.21	9	0.62
10,000	689.48	1,000	68.95	100	6.90	10	0.69

**FIGURE A-9  
POUNDS PER SQUARE INCH TO KILOPASCALS CONVERSION TABLE  
1 PSI = 6.895 kPa**

PSI	kPa	PSI	kPa
10	68.95	1	6.90
20	137.90	2	13.79
30	206.84	3	20.68
40	275.80	4	27.58
50	344.70	5	34.47
60	413.64	6	41.36
70	482.58	7	48.26
80	551.52	8	55.15
90	620.46	9	62.05
100	689.48	10	68.95

**A**

Appendix A

FIGURE A-10  
FAHRENHEIT TO CELSIUS (Centigrade) CONVERSION TABLE  
(DEGREES F - 32°) ÷ 1.8 = DEGREES C

deg F	deg C	deg F	deg C	deg F	deg C	deg F	deg C
1	-17.2	51	10.6	101	38.3	151	66.1
2	-16.7	52	11.1	102	38.9	152	66.7
3	-16.1	53	11.7	103	39.4	153	67.2
4	-15.6	54	12.2	104	40.0	154	67.8
5	-15.0	55	12.8	105	40.6	155	68.3
6	-14.4	56	13.3	106	41.1	156	68.9
7	-13.9	57	13.9	107	41.7	157	69.4
8	-13.3	58	14.4	108	42.2	158	70.0
9	-12.8	59	15.0	109	42.8	159	70.6
10	-12.2	60	15.6	110	43.3	160	71.1
11	-11.7	61	16.1	111	43.9	161	71.7
12	-11.1	62	16.7	112	44.4	162	72.2
13	-10.6	63	17.2	113	45.0	163	72.8
14	-10.0	64	17.8	114	45.6	164	73.3
15	-9.4	65	18.3	115	46.1	165	73.9
16	-8.9	66	18.9	116	46.7	166	74.4
17	-8.3	67	19.4	117	47.2	167	75.0
18	-7.8	68	20.0	118	47.8	168	75.6
19	-7.2	69	20.6	119	48.3	169	76.1
20	-6.7	70	21.1	120	48.9	170	76.7
21	-6.1	71	21.7	121	49.4	171	77.2
22	-5.6	72	22.2	122	50.0	172	77.8
23	-5.0	73	22.8	123	50.6	173	78.3
24	-4.4	74	23.3	124	51.1	174	78.9
25	-3.9	75	23.9	125	51.7	175	79.4
26	-3.3	76	24.4	126	52.2	176	80.0
27	-2.8	77	25.0	127	52.8	177	80.6
28	-2.2	78	25.6	128	53.3	178	81.1
29	-1.7	79	26.1	129	53.9	179	81.7
30	-1.1	80	26.7	130	54.4	180	82.2
31	-0.6	81	27.2	131	55.0	181	82.8
32	0.0	82	27.8	132	55.6	182	83.3
33	0.6	83	28.3	133	56.1	183	83.9
34	1.1	84	28.9	134	56.7	184	84.4
35	1.7	85	29.4	135	57.2	185	85.0
36	2.2	86	30.0	136	57.8	186	85.6
37	2.7	87	30.6	137	58.3	187	86.1
38	3.3	88	31.1	138	58.9	188	86.7
39	3.9	89	31.7	139	59.4	189	87.2
40	4.4	90	32.2	140	60.0	190	87.8
41	5.0	91	32.8	141	60.6	191	88.3
42	5.6	92	33.3	142	61.1	192	88.9
43	6.1	93	33.9	143	61.7	193	89.4
44	6.7	94	34.4	144	62.2	194	90.0
45	7.2	95	35.0	145	62.8	195	90.6
46	7.8	96	35.6	146	63.3	196	91.1
47	8.3	97	36.1	147	63.9	197	91.7
48	8.9	98	36.7	148	64.4	198	92.2
49	9.4	99	37.2	149	65.0	199	92.8
50	10.0	100	37.8	150	65.5	200	93.3

A

**Appendix A**

FIGURE A-11  
MILES PER HOUR TO KILOMETERS  
PER HOUR CONVERSION TABLE  
1 MPH = 1.609 KM/H

MPH	KM/H	MPH	KM/H	MPH	KM/H
10	16.09	1	1.61	0.1	0.16
20	32.19	2	3.22	0.2	0.32
30	48.28	3	4.83	.03	0.48
40	64.37	4	6.44	0.4	0.64
50	80.47	5	8.05	0.5	0.80
60	96.56	6	9.66	0.6	0.97
70	112.65	7	11.27	0.7	1.13
80	128.75	8	12.87	0.8	1.29
90	144.84	9	14.48	0.9	1.45
100	160.93	10	16.09	1.0	1.61

FIGURE A-12  
U.S. GALLONS TO LITERS CONVERSION TABLE  
1 U.S. GALLON = 3.785 LITERS

GAL	LITER	GAL	LITER	GAL	LITER	GAL	LITER
100	378.54	10	37.85	1	3.79	0.1	0.38
200	757.08	20	75.71	2	7.57	0.2	0.76
300	1,135.62	30	113.56	3	11.36	0.3	1.14
400	1,514.16	40	151.42	4	15.14	0.4	1.51
500	1,892.71	50	189.27	5	18.93	0.5	1.89
600	2,271.25	60	227.12	6	22.71	0.6	2.27
700	2,649.79	70	264.98	7	26.50	0.7	2.65
800	3,028.33	80	302.83	8	30.28	0.8	3.03
900	3,406.87	90	340.69	9	34.07	0.9	3.41
1,000	3,785.41	100	378.54	10	37.85	1.0	3.79



**APPENDIX B - SAE J1273**

\* SAE J1273 - AUG 2004

Recommended Practices for Hydraulic Hose Assemblies

\* Reprinted with permission SAE J1273 AUG 2004 - © 2004 SAE International

**DISCLAIMER**

HARSCO TRACK TECHNOLOGIES, HARSCO CORPORATION RECOMMENDS THAT ALL HOSE, HOSE ASSEMBLIES AND/OR FITTINGS REPLACED BY THE CUSTOMER SHOULD BE EQUAL TO OR EXCEED THE CURRENT SPECIFICATIONS OF THE ORIGINAL EQUIPMENT SUPPLIED BY HARSCO TRACK TECHNOLOGIES, HARSCO CORPORATION. HARSCO TRACK TECHNOLOGIES, HARSCO CORPORATION WILL NOT BE LIABLE FOR ANY CLAIMS OF PERSONAL INJURY RESULTING FROM THE USE OF HOSE, HOSE ASSEMBLIES AND/OR FITTINGS THAT DO NOT MEET CURRENT ORIGINAL EQUIPMENT SPECIFICATIONS. THE CUSTOMER IS ADVISED TO COMPLY WITH SAE J1273 DECEMBER 2002, RECOMMENDED PRACTICES FOR HYDRAULIC HOSE ASSEMBLIES.

 <b>SURFACE VEHICLE RECOMMENDED PRACTICE</b>	<b>SAE</b> J1273	REV. AUG2004
	Issued 1979-09 Revised 2004-08	
	Superseding J1273 DEC2002	

**Recommended Practices for Hydraulic Hose Assemblies**

**Foreword**—This SAE Recommended Practice is intended as a guide to consider when selecting, routing, fabricating, installing, replacing, maintaining, and storing hose for fluid-power systems. It is subject to change to keep pace with experience and technical advances. For those new to hose use in fluid-power systems, this guide outlines practices to note during each phase of system design and use. Experienced designers and users skilled in achieving proper results, as well as the less experienced, can use this outline as a list of considerations to keep in mind.

Fluid power systems are complex and require extensive knowledge of both the system requirements and the various types of hose. Therefore, all-inclusive, detailed, step-by-step instructions are not practical and are beyond the scope of this document. Less experienced designers and users who need more information can consult specialists such as hose suppliers and manufacturers. This guide can improve the communication process.

**Safety Considerations**—These recommended practices involve safety considerations; note these carefully during all phases of design and use of hose systems. Improper selection, fabrication, installation, or maintenance of hose and hose assemblies for fluid-power systems may result in serious personal injury or property damage. These recommended practices can reduce the likelihood of component or system failure, thereby reducing the risk of injury or damage.

**TABLE OF CONTENTS**

1.	Scope .....	2
2.	References .....	2
3.	Explanation of Terms .....	2
4.	Safety Considerations .....	2
5.	Hose Selection and Routing .....	3
6.	Hose-Assembly Fabrication .....	10
7.	Hose Installation and Replacement .....	11
8.	Maintenance Inspection .....	13

**B**

SAE Technical Standards Board Rules provide that: "This report is published by SAE to advance the state of technical and engineering sciences. The use of this report is entirely voluntary, and its applicability and suitability for any particular use, including any patent infringement arising therefrom, is the sole responsibility of the user."

SAE reviews each technical report at least every five years at which time it may be reaffirmed, revised, or cancelled. SAE invites your written comments and suggestions.

Copyright © 2004 SAE International

All rights reserved. No part of this publication may be reproduced, stored in a retrieval system or transmitted, in any form or by any means, electronic, mechanical, photocopying, recording, or otherwise, without the prior written permission of SAE.

**TO PLACE A DOCUMENT ORDER:**

Tel: 877-606-7323 (inside USA and Canada)  
 Tel: 724-776-4970 (outside USA)  
 Fax: 724-776-0790  
 Email: [custsvc@sae.org](mailto:custsvc@sae.org)  
<http://www.sae.org>

**SAE WEB ADDRESS:**



**SAE J1273 Revised AUG2004**

9. Hose Storage ..... 13  
10. Notes ..... 14

1. **Scope**—SAE J1273 provides guidelines for selection, routing, fabrication, installation, replacement, maintenance, and storage of hose and hose assemblies for fluid-power systems. Many of these SAE Recommended Practices also may be suitable for other hoses and systems.

2. **References**

2.1 **Applicable Publications**—The following publications form a part of this specification to the extent specified herein. Unless otherwise specified, the latest issue of SAE publications shall apply.

2.1.1 SAE PUBLICATIONS—Available from SAE, 400 Commonwealth Drive, Warrendale, PA 15096-0001.

- SAE J343—Test and Procedures for SAE 100 R Series Hydraulic Hose and Hose Assemblies
- SAE J514—Hydraulic Tube Fittings
- SAE J517—Hydraulic Hose
- SAE J1927—Cumulative Damage Analysis for Hydraulic Hose Assemblies

2.1.2 ISO PUBLICATION—Available from ANSI, 25 West 43rd Street, New York, NY 10036-8002.

- ISO 3457—Earth moving machinery—Guards and shields—Definitions and specifications

3. **Definitions**—These explanations serve only to clarify this document and are not intended to stand alone. They are presented sequentially, with the former helping to explain the latter.

3.1 **Fluid Power**—Energy transmitted and controlled using pressurized hydraulic fluids or compressed air.

3.2 **Hose**—Flexible conductor. In this document, the term hose also may refer to a hose assembly with related accessories used in fluid power applications.

3.3 **Hose Fitting or Fitting**—Connector which can be attached to the end of a hose.

3.4 **Hose Assembly**—Hose with hose fittings attached.

3.5 **Hose Failure**—Occurrence in which a hose stops meeting system requirements.

3.6 **Hose Service Life**—Length of time a hose meets system requirements without needing replacement.

4. **Safety Considerations**—Listed in 4.1 to 4.7 are some potential conditions and situations that may lead to personal injury and/or property damage. This list is not necessarily all inclusive. Consider reasonable and feasible means, including those described in this section, to reduce the risk of injuries or property damage.

Training, including the information in this document, for operators, maintenance personnel, and other individuals working with hoses under pressure is encouraged.

4.1 **Fluid Injections**—Fine streams of escaping pressurized fluid can penetrate skin and enter a human body. These fluid injections may cause severe tissue damage and loss of limb.

Consider various means to reduce the risk of fluid injections, particularly in areas normally occupied by operators. Consider careful routing, adjacent components, warnings, guards, shields, and training programs.



SAE J1273 Revised AUG2004

Relieve pressure before disconnecting hydraulic or other lines. Tighten all connections before applying pressure.

Avoid contact with escaping fluids. Treat all leaks as though pressurized and hot enough to burn skin. Never use any part of your body to check a hose for leaks.

If a fluid-injection accident occurs, see a doctor immediately. **DO NOT DELAY OR TREAT AS A SIMPLE CUT!** Any fluid injected into the skin must be surgically removed *within a few hours* or gangrene may result. Doctors unfamiliar with this type of injury should consult a knowledgeable medical source.

- 4.2 Whipping Hose**—If a pressurized hose assembly blows apart, the fittings can be thrown off at high speed, and the loose hose can flail or whip with great force. This is particularly true in compressible-fluid systems.

When this risk exists, consider guards and restraints to protect against injury.

- 4.3 Burns from Conveyed Fluids**—Fluid-power media may reach temperatures that can burn human skin. If there is risk of burns from escaping fluid, consider guards and shields to prevent injury, particularly in areas normally occupied by operators.

- 4.4 Fire and Explosions from Conveyed Fluids**—Most fluid-power media, including fire-resistant hydraulic fluids, will burn under certain conditions. Fluids which escape from pressurized systems may form a mist or fine spray which can flash or explode upon contact with an ignition source.

Consider selecting, guarding, and routing hose to minimize the risk of combustion (see Section 5 and ISO 3457).

- 4.5 Fire and Explosions from Static-Electric Discharge**—Fluid passing through hose can generate static electricity, resulting in static-electric discharge. This may create sparks that can ignite system fluids or gases in the surrounding atmosphere.

When this potential exists, select hose specifically designed to carry the static-electric charge to ground.

- 4.6 Electrical Shock**—Electrocution could occur if hose conducts electricity through a person. Most hoses are conductive. Many contain metal or have metal fittings. Even nonconductive hoses can be conduits for electricity if they carry conductive fluids.

Be aware of routing or using hose near electrical sources. When this cannot be avoided, select appropriate hose. Nonconductive hoses should be considered. SAE J517—100R7 and 100R8 hoses, with orange covers marked “Nonconductive” are available for applications requiring nonconductive hose.

- 4.7 Mechanisms Controlled by Fluid Power**—Mechanisms controlled by fluids in hoses can become hazardous when a hose fails. For example, when a hose bursts, objects supported by fluid pressure may fall, or vehicles or machines may lose their brakes or steering.

If mechanisms are controlled by fluid power, consider safe modes of failure that minimize risks of injury or damage.

- 5. Hose Selection and Routing**—A wide variety of interacting factors influence hose service life and the ability of each fluid-power system to operate satisfactorily, and the combined effects of these factors on service life are often unpredictable. Therefore, these documents should not be construed as design standards. For applications outside the specifications in SAE J517, SAE J514, or other relevant design standards, performance of hose assemblies should be determined by appropriate testing.

**SAE J1273 Revised AUG2004**

Carefully analyze each system. Then design routings and select hose and related components to meet the system-performance and hose-service-life requirements, and to minimize the risks of personal injury and/or property damage. Consider the following factors:

- 5.1 System Pressures**—Excessive pressure can accelerate hose assembly failure. Analyze the steady-state pressures, and the frequency and amplitude of pressure surges, such as pulses and spikes. These are rapid and transient rises in pressure which may not be indicated on many common pressure gages and can be identified best on high-frequency-response electronic measuring instruments.

For maximum hose service life, hose selection should be based on a system pressure, including surges, that is less than the hose maximum working pressure. Hose may be used above its maximum working pressure where reduced life expectancy is acceptable. SAE J1927 provides one method to help predict wire-reinforced hose service life for a given hydraulic application, where the surge pressure peaks vary, and/or the highest pressure peaks occur infrequently.

- 5.2 Suction**—For suction applications, such as inlet flow to pumps, select hose to withstand both the negative and positive pressures the system imposes on the hose.
- 5.3 External Pressure**—In certain applications, such as in autoclaves or under water, the external environmental pressures may exceed the fluid pressure inside the hose. In these applications, consider the external pressures, and if necessary, consult the manufacturers.
- 5.4 Temperature**—Exceeding hose temperature ratings may significantly reduce hose life. Select hose so the fluid and ambient temperatures, both static and transient, fall within the hose ratings. The effects of external heat sources should not raise the temperature of the hose above its maximum operating temperature. Select hose, heat shields, sleeving, and other methods for these requirements, and route or shield hose to avoid hose damage from external heat sources.
- 5.5 Permeation**—Permeation, or effusion, is seepage of fluid through the hose. Certain materials in hose construction are more permeable than others. Consider the effects of permeation when selecting hose, especially with gaseous fluids. Consult the hose and fluid manufacturers for permeability information.
- 5.6 Hose-Material Compatibility**—Variables that can affect compatibility of system fluids with hose materials include, but are not limited to:
- a. Fluid pressure
  - b. Temperature
  - c. Concentration
  - d. Duration of exposure

Because of permeation (see 5.5), consider compatibility of system fluids with the hose, tube, cover, reinforcement, and fittings. Consult the fluid and hose manufacturers for compatibility information.

**NOTE**—Many fluid/elastomer compatibility tables in manufacturers' catalogs show ratings based on fluids at 21 °C, room temperature. These ratings may change at other temperatures. Carefully read the notes on the compatibility tables, and if in doubt, consult the manufacturer.

SAE J1273 Revised AUG2004

**5.7 Environment**—Environmental conditions can cause hose and fitting degradation. Conditions to evaluate include, but are not limited to:

- a. Ultraviolet light
- b. Salt water
- c. Air pollutants
- d. Temperature (see 5.4)
- e. Ozone
- f. Chemicals
- g. Electricity
- h. Abrasion

If necessary, consult the manufacturers for more information.

**5.8 Static-Electric Discharge**—Fluid passing through hose can generate static electricity resulting in static-electric discharge. This may create sparks that can puncture hose. If this potential exists, select hose with sufficient conductivity to carry the static-electric charge to ground.

**5.9 Sizing**—The power transmitted by pressurized fluid varies with pressure and rate of flow. Select hose with adequate size to minimize pressure loss, and to avoid hose damage from heat generation or excessive velocity. Conduct calculations, or consult the manufacturers for sizing at flow velocities.

**5.10 Unintended Uses**—Hose assemblies are designed for the internal forces of conducted fluids. Do not pull hose or use it for purposes that may apply external forces for which the hose or fittings were not designed.

**5.11 Specifications and Standards**—When selecting hose and fittings for specific applications, refer to applicable government, industry, and manufacturer's specifications and standards.

**5.12 Unusual Applications**—Applications not addressed by the manufacturer or by industry standards may require special testing prior to selecting hose.

**5.13 Hose Cleanliness**—The cleanliness requirements of system components, other than hose, will determine the cleanliness requirements of the application. Consult the component manufacturers' cleanliness information for all components in the system. Hose assemblies vary in cleanliness levels; therefore, specify hose assemblies with adequate cleanliness for the system.

**5.14 Hose Fittings**—Selection of the proper hose fittings for the hose and application is essential for proper operation and safe use of hose and related assembly equipment. Hose fittings are qualified with the hose. Therefore, select only hose fittings compatible with the hose for the applications.

Improper selection of hose fittings or related assembly equipment for the application can result in injury or damage from leaks, or from hose assemblies blowing apart (see 4.2, 6.2, 6.3, and 6.4).

**5.15 Vibration**—Vibration can reduce hose service life. If required, conduct tests to evaluate the frequency and amplitude of system vibration. Clamps or other means may be used to reduce the effects of vibration. Consider the vibration requirements when selecting hose and predicting service life.

**5.16 Hose Cover Protection**—Protect the hose cover from abrasion, erosion, snagging, and cutting. Special abrasion-resistant hoses and hose guards are available for additional protection. Route hose to reduce abrasion from hose rubbing other hose or objects that may abrade it. (See Figure 1)

SAE J1273 Revised AUG2004

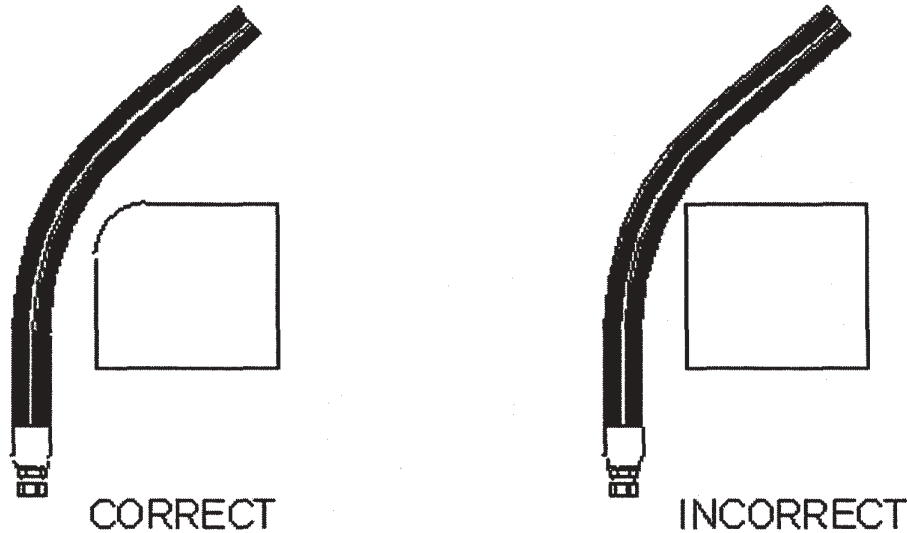

FIGURE 1—PREVENTION OF EXTERNAL DAMAGE

**5.17 External Physical Abuse**—Route hose to avoid:

- a. Tensile loads
- b. Side loads
- c. Flattening
- d. Thread damage
- e. Kinking
- f. Damage to sealing surfaces
- g. Abrasion
- h. Twisting

**5.18 Swivel-Type Adapters**—Swivel-type fittings or adapters do not transfer torque to hose while being tightened. Use these as needed to prevent twisting during installation.

**5.19 Live Swivels**—If two components in the system are rotating in relation to each other, live swivels may be necessary. These connectors reduce the torque transmitted to the hose.

**5.20 Slings and Clamps**—Use slings and clamps to support heavy or long hose and to keep it away from moving parts. Use clamps that prevent hose movement that will cause abrasion.

**5.21 Minimum Bend Radius**—The minimum bend radius is defined in SAE J343 and is specified in other SAE standards and hose manufacturer's product literature. Routing at less than minimum bend radius may reduce hose life. Sharp bending at the hose/fitting juncture may result in leaking, hose rupturing, or the hose assembly blowing apart (see 4.2 and Figures 2A and 2B).

SAE J1273 Revised AUG2004

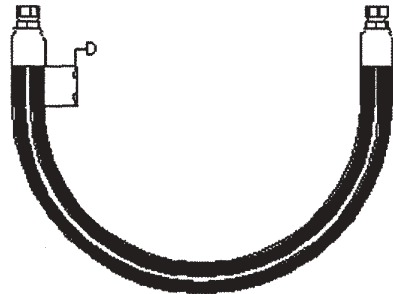

CORRECT



INCORRECT

FIGURE 2A—MINIMUM BEND RADIUS

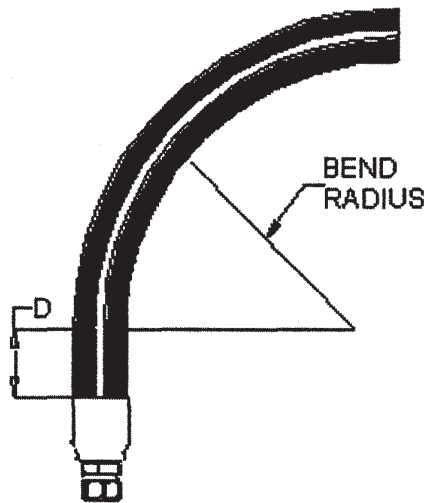

CORRECT

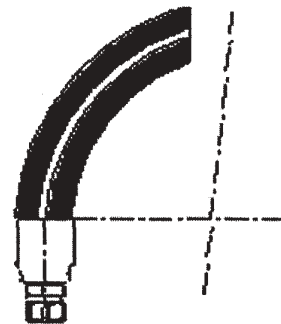

INCORRECT

FIGURE 2B—MINIMUM BEND RADIUS

B

SAE J1273 Revised AUG2004

**5.22 Elbows and Adapters**—In special cases, use elbows or adapters to relieve hose strain (see Figure 3).

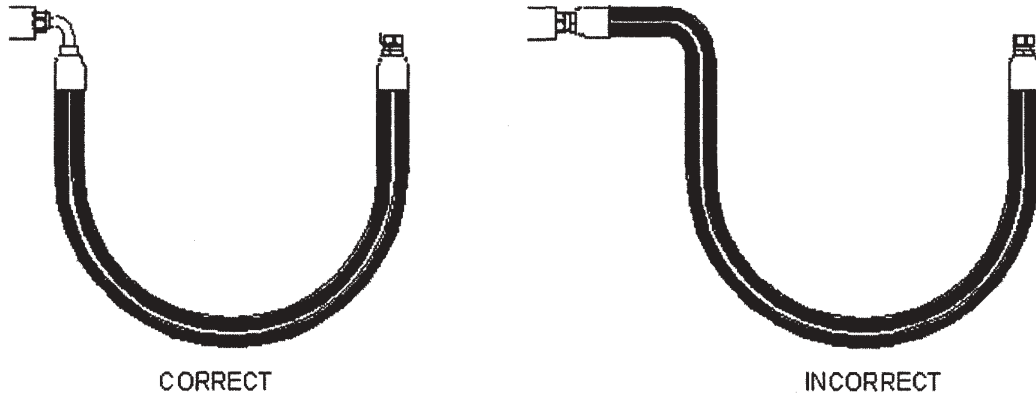

FIGURE 3—ELBOWS AND ADAPTERS

**5.23 Lengths**—Unnecessarily long hose can increase pressure drop and affect system performance. When pressurized, hose that is too short may pull loose from its fittings, or stress the fitting connections, causing premature metallic or seal failures. When establishing hose length, refer to Figures 4, 5, and 6; and use the following practices:

**5.23.1 MOTION ABSORPTION**—Provide adequate hose length to distribute movement and prevent bends smaller than the minimum bend radius.

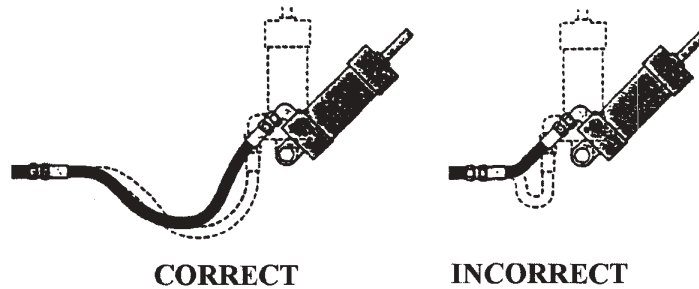

FIGURE 4—MOTION ABSORPTION

**5.23.2 HOSE AND MACHINE TOLERANCES**—Design hose to allow for changes in length due to machine motion and tolerances.

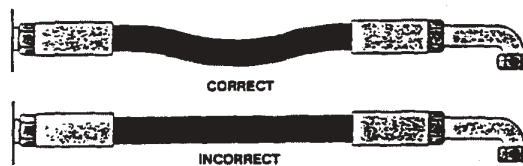

FIGURE 5—HOSE AND MACHINE TOLERANCES

B

SAE J1273 Revised AUG2004

5.23.3 HOSE LENGTH CHANGE DUE TO PRESSURE—Design hose to accommodate length changes from changing pressures. Do not cross or clamp together high- and low-pressure hoses. The difference in length changes could wear the hose covers.

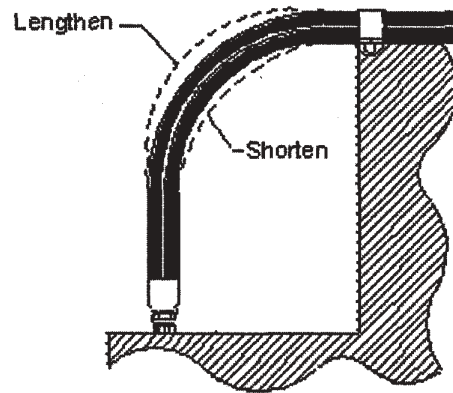

FIGURE 6—HOSE LENGTH CHANGE DUE TO PRESSURE

5.24 Hose Movement and Bending—Hose allows relative motion between system components. Analyze this motion when designing hose systems. The number of cycles per day may significantly affect hose life. Also avoid multiple planes of motion and twisting motion. Consider the motion of the hose when selecting hose and predicting service life. In applications that require hose to move or bend, refer to Figures 7A, 7B, and 8; and use these practices:

5.24.1 BEND IN ONLY ONE PLANE TO AVOID TWISTING

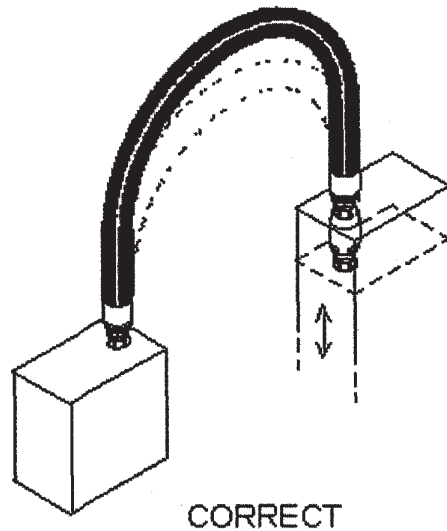
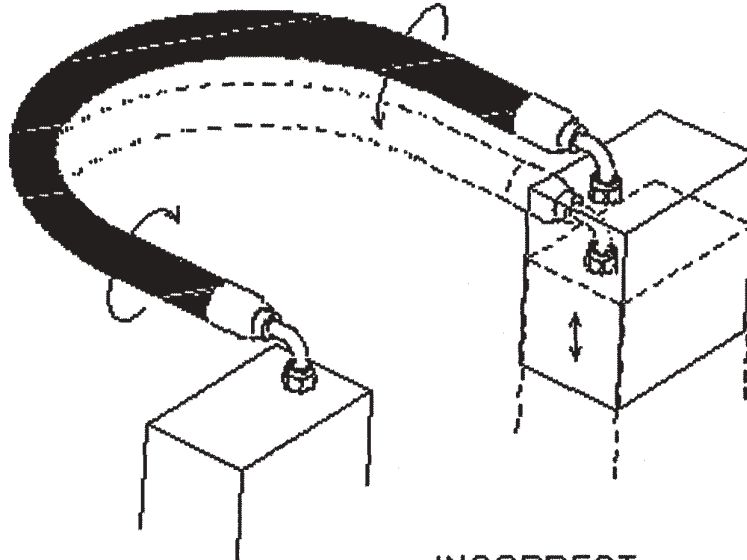

FIGURE 7A—BEND IN ONLY ONE PLANE TO AVOID TWISTING

B



SAE J1273 Revised AUG2004



INCORRECT

FIGURE 7B—BEND IN ONLY ONE PLANE TO AVOID TWISTING

5.24.2 PREVENT HOSE BENDING IN MORE THAN ONE PLANE—If hose follows a compound bend, couple it into separate segments, or clamp it into segments that flex in only one plane.

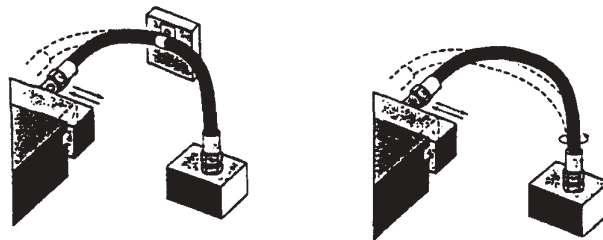

CORRECT

INCORRECT

FIGURE 8—PREVENT HOSE BENDING IN MORE THAN ONE PLANE

6. **Hose-Assembly Fabrication**—Persons fabricating hose assemblies should be trained in the proper use of equipment and materials. The manufacturers' instructions and the practices listed as follows must be followed. Properly assembled fittings are vital to the integrity of a hose assembly. Improperly assembled fittings can separate from the hose and may cause serious injury or property damage from whipping hose, or from fire or explosion of vapor expelled from the hose.

**SAE J1273 Revised AUG2004**

**6.1 Component Inspection**—Prior to assembly, examine components for:

- a. Style or type
- b. Cleanliness
- c. Loose covers
- d. Nicks
- e. Size
- f. Inside obstructions
- g. Visible defects
- h. Damage
- i. Length
- j. Blisters
- k. Burrs

**6.2 Hose Fittings**—Hose fitting components from one manufacturer are not usually compatible with fitting components supplied by another manufacturer. For example, do not use a hose fitting nipple from one manufacturer with a hose socket from another manufacturer.

It is the responsibility of the fabricator to consult the manufacturer's written instructions or the manufacturer directly for information on proper fitting components.

**6.3 Hose and Fitting Compatibility**—Care must be taken to determine proper compatibility between the hose and fitting. Base selection on the manufacturers' recommendations substantiated by testing to industry standards such as SAE J517. Hose from one manufacturer is not usually compatible with fittings from another. Do not intermix hose and fittings from two manufacturers without approval from both manufacturers.

**6.4 Hose Assembly Equipment**—Assembly equipment from one manufacturer is usually not interchangeable with that from another manufacturer. Hoses and fittings from one manufacturer should not generally be assembled with the equipment of another manufacturer.

**6.5 Safety Equipment**—During fabrication, use proper safety equipment, including eye protection, breathing apparatus, and adequate ventilation.

**6.6 Reuse of Hose and Fittings**—When fabricating hose assemblies, do **not** reuse:

- a. Field-attachable fittings that have blown or pulled off hose
- b. Any part of hose fittings that were permanently crimped or swaged to hose
- c. Hose that has been in service after system checkout (see 7.7)

**6.7 Cleanliness of Hose Assemblies**—Hose assemblies may be contaminated during fabrication. Clean hoses to specified cleanliness levels (see 5.13).

**7. Hose Installation and Replacement**—Use the following practices when installing hose assemblies in new systems or replacing hose assemblies in existing systems:

**7.1 Pre-Installation Inspection**—Before installing hose assemblies, examine:

- a. Hose length and routing for compliance with original design
- b. Assemblies for correct style, size, length, and visible nonconformities
- c. Fitting sealing surfaces for burrs, nicks, or other damage

**NOTE**—When replacing hose assemblies in existing systems, verify that the replacement is of equal quality to the original assembly.

SAE J1273 Revised AUG2004

- 7.2 **Handling During Installation**—Handle hose with care during installation. Kinking hose, or bending at less than minimum bend radius may reduce hose life. Avoid sharp bending at the hose/fitting juncture (see 5.21).
- 7.3 **Twist Angle and Orientation**—Pressure applied to a twisted hose may shorten the life of the hose or loosen the connections. To avoid twisting, use the hose lay line or marking as a reference (see Figure 9).

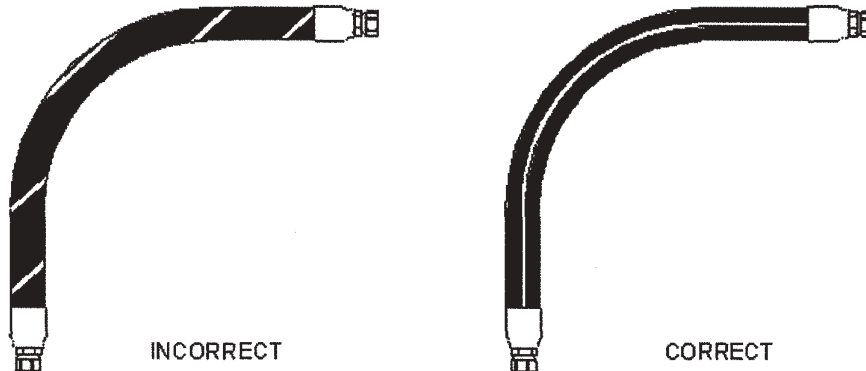

FIGURE 9—TWIST ANGLE AND ORIENTATION

- 7.4 **Securement and Protection**—Install necessary restraints and protective devices. Determine that such devices do not create additional stress or wear points.
- 7.5 **Routing**—Review proper routing practices provided in Section 5 and make appropriate corrections to obtain optimum performance.
- 7.6 **Assembly Torque**—The connection end of a hose fitting is normally threaded to obtain a tight pressure seal when attached to a port, an adapter, or another fitting. Sometimes bolts or screws provide the threaded connection. Each size and type of connection requires different torque values, and these may vary due to type of material or exterior coating.

Follow appropriate torquing instructions to obtain a proper pressure seal without over-torquing. A properly calibrated torque wrench should be used to tighten each connection, except when the manufacturer specifies tightening a specified number of hex flat turns beyond finger tight to obtain a seal.

- 7.7 **System Checkouts**—In hydraulic or other liquid systems, eliminate all air entrapment after completing the installation. Follow manufacturers' instructions to test the system for possible malfunctions and leaks.
  - 7.7.1 To avoid injury during system checkouts:
    - a. Do not touch any part of the system when checking for leaks (see 4.1).
    - b. Stay out of potentially hazardous areas while testing hose systems (see Section 4).
    - c. Relieve system pressure before tightening connections.

**SAE J1273 Revised AUG2004**

**8. Maintenance Inspection**—A hose and fitting maintenance program may reduce equipment downtime, maintain peak operating performance, and reduce the risk of personal injury and/or property damage. The user should design and implement a maintenance program that suits the specific application and each specific hose in that application.

**8.1 Inspection Frequency**—Evaluate factors such as the nature and severity of the application, past history, and manufacturers' information to establish the frequency of visual inspections and functional tests.

**8.2 Visual Inspection (Hose and Fittings)**—Visually inspect hose and fittings for:

- a. Leaks at hose fitting or in hose
- b. Damaged, cut, or abraded cover
- c. Exposed reinforcement
- d. Kinked, crushed, flattened, or twisted hose
- e. Hard, stiff, heat cracked, or charred hose
- f. Blistered, soft, degraded, or loose cover
- g. Cracked, damaged, or badly corroded fittings
- h. Fitting slippage on hose
- i. Other signs of significant deterioration

If any of these conditions exist, evaluate the hose assemblies for correction or replacement.

**8.3 Visual Inspection (All Other Components)**—When visually inspecting hose and fittings, inspect for related items including:

- a. Leaking ports
- b. Damaged or missing hose clamps, guards, or shields
- c. Excessive dirt and debris around hose
- d. System fluid: level, type, contamination, condition, and air entrainment

If any of these are found, address them appropriately.

**8.4 Functional Test**—Functional tests determine if systems with hose are leak free and operating properly. Carry out functional tests per information from equipment manufacturers.

**9. Hose Storage**—Age control and the manner of storage can affect hose life. Use the following practices when storing hose.

**9.1 Age Control**—Maintain a system of age control to determine that hose is used before its shelf life has expired. Shelf life is the period of time when it is reasonable to expect the hose to retain full capabilities for rendering the intended service.

Store hose in a manner that facilitates age control and first-in, first-out usage based on manufacturing date on hose or hose assembly. Per SAE J517:

- a. Shelf life of rubber hose in bulk form, or in hose assemblies passing visual inspection and proof test, is forty quarters (ten years) from the date of manufacture.
- b. Shelf life of thermoplastic and polytetrafluoroethylene hose is considered to be unlimited.

**SAE J1273 Revised AUG2004**

**9.2 Storage**—Store hose and hose assemblies in a cool, dark, dry area with the ends capped. When storing hose, take care to avoid damage that could reduce hose life, and follow the manufacturers' information for storage and shelf life. Examples of factors that can adversely affect hose products in storage are:

- a. Temperature
- b. Ozone
- c. Oils
- d. Corrosive liquids and fumes
- e. Rodents
- f. Humidity
- g. Ultraviolet light
- h. Solvents
- i. Insects
- j. Radioactive materials

If there are questions regarding the quality or usability of hose or hose assemblies, evaluate appropriately:

- a. Flex the hose to the minimum bend radius and compare it with new hose. After flexing, examine the cover and tube for cracks. If any appear, no matter how small, reject the hose.
- b. If the hose is wire reinforced, and the hose is unusually stiff, or a cracking sound is heard during flexing, check for rust by cutting away a section of the cover from a sample. Rust would be another reason for rejection.
- c. If doubt still persists, contact hose assembler to conduct proof-pressure tests or any other tests needed to verify hose quality.

**10. Notes**

**10.1 Marginal Indicia**—The (R) is for the convenience of the user in locating areas where technical revisions have been made to the previous issue of the report. If the symbol is next to the report title, it indicates a complete revision of the report.

PREPARED BY THE SAE FLUID CONDUCTORS AND CONNECTORS TECHNICAL COMMITTEE SC3—  
TRAINING AND EDUCATION SUBCOMMITTEE

**SAE J1273 Revised AUG2004**

**Rationale**—To correct verbiage in Section 9.1.

**Relationship of SAE Standard to ISO Standard**—Not applicable.

**Application**—SAE J1273 provides guidelines for selection, routing, fabrication, installation, replacement, maintenance, and storage of hose and hose assemblies for fluid-power systems. Many of these SAE Recommended Practices also may be suitable for other hoses and systems.

**Reference Section**

SAE J343—Test and Procedures for SAE 100 R Series Hydraulic Hose and Hose Assemblies

SAE J514—Hydraulic Tube Fittings

SAE J517—Hydraulic Hose

SAE J1927—Cumulative Damage Analysis for Hydraulic Hose Assemblies

ISO 3457—Earth moving machinery—Guards and shields—Definitions and specifications

**Developed by the SAE Fluid Conductors and Connectors Technical Committee SC3—Training and Education Subcommittee**

**Sponsored by the SAE Fluid Conductor and Connectors Technical Committee**

## HARSCO TRACK TECHNOLOGIES

### TERMS AND CONDITIONS OF SALE

1. ACCEPTANCE OF TERMS AND CONDITIONS. The acceptance of the terms and conditions contained herein is an essential prerequisite to any contract of sale made by HTT, a Division of Harsco Corporation (hereinafter "HTT"). Any offer or acceptance by HTT is made subject to the terms and conditions contained herein and no additional or different terms offered by Buyer shall become a part of the agreement of sale between HTT and Buyer unless such terms have been expressly approved in writing by an authorized agent of HTT. If this document is an offer, acceptance of this offer is expressly limited to the terms hereof, and HTT reserves the right to withdraw this offer at any time before its acceptance by Buyer. If this document has been issued by HTT in response to a written offer made by Buyer, HTT's acceptance of Buyer's offer is expressly conditioned on Buyer's assent to the additional or different terms contained herein. If these terms and conditions are not acceptable, Buyer shall notify HTT in writing at once. Buyer's action in (a) accepting any goods manufactured and delivered hereunder, or (b) receiving this document without disaffirmance within three (3) business days of receipt shall constitute an unqualified acceptance by Buyer of the terms and conditions contained herein.
2. INVOICES AND PAYMENT TERMS. Product shipments shall be invoiced based on the shipment date. Payment terms are as indicated in the quotation letter and payment is due at HTT's designated lockbox.
3. TAXES. Buyer shall pay to HTT the amount of any and all taxes, excises, or other charges (except income or gross receipt taxes) which HTT may be required to pay to or to collect for any government, whether national, state or local, based upon or measured by the sale or use of the Product sold hereunder provided the amount of the tax or other charge is set forth separately on HTT's invoice.
4. DELIVERY. All delivery terms and dates are subject to the availability of the necessary shop space, transportation, and production hours.
5. FORCE MAJEURE. Neither HTT nor Buyer shall be liable for delay or failure to perform in whole or in part by reason of contingencies beyond its control, whether herein specifically enumerated or not, including among others, acts of God, force majeure, war, acts of war, revolution, civil commotion, riot, acts of public enemies, blockage or embargo, fire, explosion, breakdown of plant, strike, lockout, labor dispute, casualty or accident, earthquake, epidemic, flood, cyclone, tornado, hurricane or other windstorm, lack or failure of sources of labor, power, supplies; lack, or failure or excessive cost of raw materials which are used in the manufacture of Product by HTT, or by reason of any law, order, proclamation, regulation, ordinance, demand, requisition or requirement or any other act of governmental authority, whether national, state or local, including court orders, judgments, or decrees, or any other cause whatsoever, whether similar or dissimilar to those above enumerated, or actions of any nature beyond the reasonable control of HTT or Buyer.
6. LIMITED WARRANTY. HTT warrants products of its manufacture to be free of defects in material and workmanship, under normal use and service for a period of six (6) months from date of delivery to the original user. The obligation of HTT under this warranty is limited to repairing or replacing at its factories, or other location designated by it, any part or parts thereof which are returned within 30 days of the date when failure occurs or defect is noted, with transportation charges prepaid, and which upon examination appears to the satisfaction of HTT to have been defective. Such free repair or replacement does not include transportation charges, or the cost of installing the new part or any other expense incident thereto. HTT will not be liable for other loss, damage, or expense directly or indirectly arising from the use of its product, nor will HTT be liable for special, incidental, or consequential damages. Ordinary wear and tear, and damage from abuse, misuse, neglect or alteration are not covered by this warranty. HTT assumes no liability for expense incurred or repairs made outside its factories except by written consent. This warranty is null and void if instructions and operating procedures are not followed. Equipment and parts not manufactured by HTT, but which are furnished in connection with HTT products, are covered directly by the warranty of the manufacturer supplying them. However, HTT will assist in obtaining adjustment on such equipment or parts when necessary. **THIS WARRANTY IS IN LIEU OF ALL OTHER WARRANTIES EXPRESSED OR IMPLIED INCLUDING ANY IMPLIED WARRANTIES OF MERCHANTABILITY OR FITNESS FOR A PARTICULAR PURPOSE, WHICH ARE HEREBY DISCLAIMED AND OF ANY OTHER OBLIGATION OR LIABILITY OF HTT. THE REMEDY SET FORTH ABOVE IS BUYER'S EXCLUSIVE REMEDY FOR A BREACH OF THE WARRANTY. UNDER NO CIRCUMSTANCES WILL HTT BE RESPONSIBLE FOR INCIDENTAL, CONSEQUENTIAL, SPECIAL OR OTHER INDIRECT DAMAGES.**
7. PRODUCT IMPROVEMENT LIABILITY DISCLAIMER. HTT reserves the right to make any changes in or improvements on its products without incurring any liability or obligation whatsoever and without being required to make any corresponding changes or improvements in products previously manufactured or sold.
8. INDEMNITY. Buyer agrees to indemnify and hold HTT harmless for all loss, cost including but not limited to legal and other cost of proceedings, and damages suffered by Buyer or claimed by third parties by or related to Buyer's use of HTT's product.
9. HAZARDOUS MATERIAL DISCLAIMER. The parts/assemblies that are used in this Product are classified as "articles" according to 29 CFR 1910.1200 (C). They are formed to a specific shape or design during manufacture, have end use function dependent upon their shape or design, and do not release any hazardous chemical under normal conditions of use. Accordingly, we are not required to supply Material Safety Data Sheets (MSDS) or to label shipping containers for "articles". However, lubricants, liquids, gaseous chemicals and solids used in operation or maintenance of the product may require that user's take occupational protective measures. MSDS sheets for such materials will be supplied to your Purchasing Manager/Safety Director to be used in you employee safety training education and environmental health training.
10. TITLE AND RISK OF LOSS. Title to, ownership of, and risk of loss, destruction or damage to the Product shall pass to Buyer upon loading at HTT's plant.
11. CANCELLATION. No accepted purchase order may be modified except with HTT's prior written consent, nor may it be canceled except with HTT's prior written consent and by prior payment to HTT of a sum equal to the total of out-of-pocket expenses incurred in connection with the purchase order, including but not limited to any charges made to HTT by suppliers for cancellation, plus a reasonable sum for overhead expenses and lost profits, as determined by HTT.
12. SECURITY. HTT reserves the right to require payment in advance or satisfactory security or guaranty that an invoice will be promptly paid when due if at any time Buyer's financial responsibility becomes impaired or unsatisfactory to HTT.
13. COSTS AND ATTORNEY'S FEES. Buyer shall pay all costs and reasonable attorneys' fees of HTT incurred in connection with the enforcement of these terms of sale between the parties hereto.
14. EFFECT OF INVALIDITY. The invalidity in whole or in part of any provision hereof shall not affect the validity of any other provision.
15. WAIVER. No waiver by HTT of any breach of contract shall be deemed to be a waiver of any other or subsequent breach. All rights and remedies available to HTT shall be cumulative and in addition to any other rights and remedies provided herein or by law.
16. Governing Law, Jurisdiction and Venue. These terms of sale between the parties hereto shall be governed by and construed in accordance with the laws of the State of Pennsylvania. The parties agree that any controversy arising under the contract herein shall be determined by the Courts of the State of Pennsylvania, and both parties hereby submit and consent to the jurisdiction of said Courts and agree that venue for any action arising hereunder shall lie in Cumberland County, State of Pennsylvania.

# **HTT**

## **Harsco Track Technologies**

---

**Harsco**

**HARSCO TRACK TECHNOLOGIES**  
**HARSCO CORPORATION**  
415 North Main Street  
Fairmont, Minnesota, 56031-1837 U.S.A.

BULLETIN 1526

Printed In U.S.A.

ISSUED 10 - 2006

© 2006 HARSCO TRACK TECHNOLOGIES, HARSCO CORPORATION