

HARSCO

RAIL

**HR4000 SERIES A2
REAR UNIVERSAL HY-RAIL®
GUIDE WHEEL UNIT
HYDRAULICALLY OPERATED**

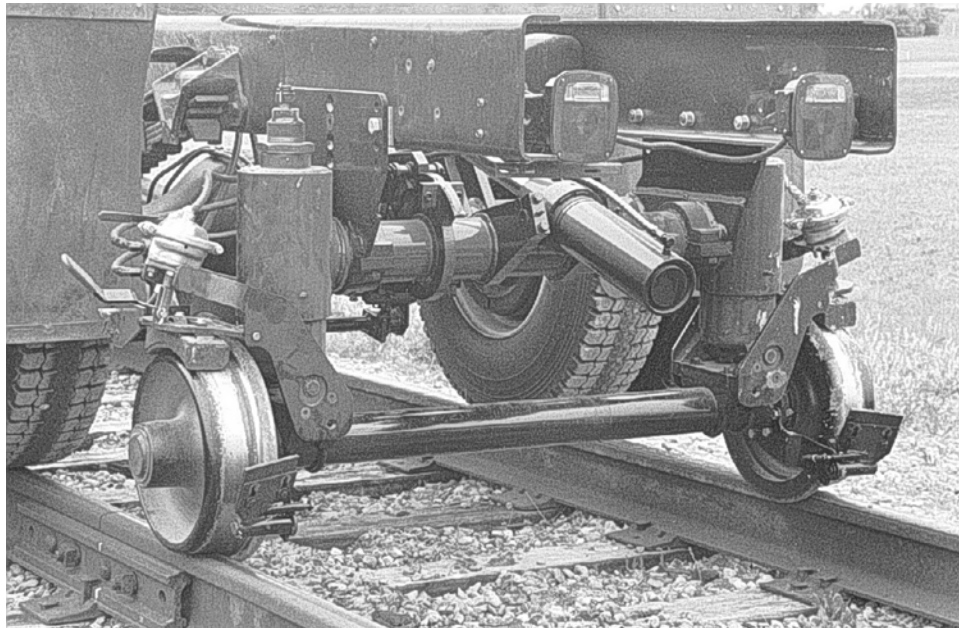

**OPERATOR'S SERVICE
AND PARTS MANUAL**

ISSUED 3 - 2011

BULLETIN 1269A

© 2011 HARSCO RAIL, HARSCO CORPORATION



- **THIS MANUAL CONTAINS VITAL INFORMATION FOR THE SAFE USE AND EFFICIENT OPERATION OF THE VEHICLE EQUIPPED WITH HY-RAIL® GUIDE WHEEL EQUIPMENT. CAREFULLY READ THIS OPERATOR'S MANUAL BEFORE USING THE VEHICLE. FAILURE TO ADHERE TO THE INSTRUCTIONS COULD RESULT IN BODILY INJURY AND/OR PROPERTY DAMAGE.**

HY-RAIL® is a registered trademark of Harsco Rail, Harsco Corporation.

When this manual is received, record the rail pilot unit serial numbers in the spaces provided in the General Information and Parts Sections for future reference, in case the serial number tags ever become unreadable. A Manual must remain with the vehicle. Additional or replacement manuals may be obtained by calling or writing Harsco Rail, Harsco Corporation.

All information, illustrations and specifications in this manual are based on the latest information available at the time of publication. Harsco Rail, Harsco Corporation reserves the right to make changes at any time without notice.

FACILITY LOCATIONS

Harsco Rail
415 North Main Street
Fairmont, MN
56031-1837
Tel: (507) 235-3361
Fax: (507) 235-7370

Harsco Rail
2401 Edmund Road, Box 20
Cayce-West Columbia, SC
29171-0020
Tel: (803) 822-9160
Fax: (803) 822-7471

Harsco Rail
200 South Jackson Road
Ludington, MI
49431
Tel: (231) 843-3431
Fax: (231) 843-4830

Harsco Rail
Giltway, Giltbrook
Nottingham, NG16 2GQ
England
Tel: 0115 938 7000
Fax: 0115 938 7001

Harsco Rail
4 Strathwyn Street, PO Box 5287
Brendale, Queensland 4500
Australia
Tel: 61 7 205 6500
Fax: 61 7 205 7369

TABLE OF CONTENTS

GENERAL INFORMATION

SECTION

1

OPERATION

SECTION

2

ADJUSTMENTS

SECTION

3

MAINTENANCE

SECTION

4

TROUBLESHOOTING

SECTION

5

PARTS

SECTION

6

VEHICLE APPLICATIONS

SECTION

7

TORQUE SPECIFICATIONS AND CONVERSION TABLES

APPENDIX

A

SAE J1273 - HOSE STANDARD

APPENDIX

B

SECTION 1 - GENERAL INFORMATION
TABLE OF CONTENTS

1.1 Safety Information 1 - 2
1.1.1 Hazard Seriousness 1 - 2
1.2 Description 1 - 5
1.3 Vehicle Orientation 1 - 5
1.4 Serial Numbers 1 - 6
1.5 Specifications 1 - 7
1.5.1 Vehicle 1 - 7
1.5.2 Guide Wheel Unit 1 - 7

1

1.1 Safety Information



SAFETY IS A CRITICAL FACTOR IN THE DESIGN OF HARSCO RAIL EQUIPMENT. THE BEST SAFETY PROGRAM STARTS WITH A SAFETY CONSCIOUS OPERATOR. THE SAFETY INFORMATION HIGHLIGHTED IN THIS BULLETIN DESCRIBES SAFE OPERATING PRACTICES FOR THE BENEFIT OF THE WORKERS WHO WILL USE OUR EQUIPMENT IN THEIR DAILY JOBS.

1.1.1 Hazard Seriousness

Signal Words: DANGER, WARNING and CAUTION are used to identify levels of hazard seriousness.



DANGER - Immediate hazards which WILL result in severe bodily injury or death.



WARNING - Hazards or unsafe practices which COULD result in severe bodily injury or death.



CAUTION - Hazards or unsafe practices which COULD result in minor bodily injury and / or product or property damage.

1.1 Safety Information



- **APPLY THE VEHICLE PARKING BRAKE AND STOP THE ENGINE WHEN PERFORMING MAINTENANCE, MAKING ADJUSTMENTS, WORKING UNDER VEHICLE OR GUIDE WHEEL EQUIPMENT OR WHENEVER UNINTENDED MOVEMENT OF THE VEHICLE COULD OCCUR, UNLESS OTHERWISE INSTRUCTED IN THIS MANUAL.**
- **MAKE SURE ALL PERSONS ARE CLEAR OF VEHICLE BEFORE PERFORMING ANY OPERATING FUNCTIONS.**
- **KEEP ALL PARTS OF THE BODY AND LOOSE CLOTHING CLEAR OF ALL MOVING PARTS OF THE VEHICLE OR GUIDE WHEEL EQUIPMENT.**
- **UNDERSTAND EQUIPMENT OPERATION AND BE AWARE OF ALL PINCH POINTS BEFORE OPERATING OR MAKING ADJUSTMENTS TO GUIDE WHEEL EQUIPMENT.**
- **IF A DERAILMENT SHOULD OCCUR WHILE VEHICLE IS OPERATING IN ELECTRIFIED 3RD-RAIL TERRITORY, VEHICLE OR GUIDE WHEEL EQUIPMENT MIGHT BE IN ELECTRICAL CONTACT WITH ELECTRIFIED RAIL. DO NOT ATTEMPT TO EXIT FROM VEHICLE UNTIL ELECTRICAL POWER TO 3RD-RAIL HAS BEEN TURNED OFF.**
- **IF THE HY-RAIL® EQUIPPED VEHICLE IS INVOLVED IN A DERAILMENT OR HIGHWAY ACCIDENT, IT MUST BE INSPECTED AND NECESSARY REPAIRS OR ADJUSTMENTS MADE TO THE VEHICLE AND / OR HY-RAIL® EQUIPMENT PRIOR TO ITS NEXT OPERATION ON THE RAILROAD TRACK.**
- **DO NOT EXCEED 25 MPH (40 km/h) WHEN OPERATING VEHICLE ON TRACK. RAILROAD RULES GOVERNING SPEEDS SHOULD BE OBSERVED AT ALL TIMES. REDUCE SPEED WHEN PROPELLING VEHICLE THROUGH SWITCHES, CROSSINGS, BRANCH LINES AND ANY SPECIAL TRACK WORKS. OPERATING VEHICLE AT UNSAFE SPEEDS COULD RESULT IN DERAILMENT OF VEHICLE.**
- **CHECK AND CORRECT GUIDE WHEEL EQUIPMENT ALIGNMENT PROMPTLY IF MISALIGNMENT IS INDICATED.**

1.1 Safety Information

1



- **AT MAXIMUM LOADED GROSS VEHICLE WEIGHT ON TRACK (including driver, passengers, equipment, tools, payload, etc.) DO NOT EXCEED ANY OF THE FOLLOWING:**
 - VEHICLE'S G.V.W.R. (Gross Vehicle Weight Rating).
 - VEHICLE'S FRONT G.A.W.R. (Gross Axle Weight Rating) OR THE FRONT GUIDE WHEEL UNIT RATED LOAD CAPACITY, WHICHEVER IS LOWER.
 - VEHICLE'S REAR G.A.W.R. (Gross Axle Weight Rating) OR THE SUM OF THE REAR GUIDE WHEEL UNIT RATED LOAD CAPACITY PLUS (+) VEHICLE'S REAR TIRE/WHEEL RATED LOAD CAPACITY, WHICHEVER IS LOWER.
 - **COMPONENTS RATED LOAD CAPACITY:**
 - A. TIRE MANUFACTURER'S RATED LOAD CAPACITY
 - B. VEHICLE'S WHEEL RATED LOAD CAPACITY
 - C. REAR GUIDE WHEEL UNIT RATED LOAD CAPACITY:
 - 20,000 lbs (9,072 kg)
 - 10,000 lbs (4,536 kg) maximum per guide wheel

FAILURE TO HEED THESE WARNINGS COULD RESULT IN SEVERE BODILY INJURY.



- **OBSERVE AND FOLLOW ALL RAILROAD SAFETY RULES AND REGULATIONS.**
- **KNOW THE POSITIONS AND FUNCTIONS OF ALL CONTROLS BEFORE ATTEMPTING TO OPERATE VEHICLE.**
- **THIS GUIDE WHEEL EQUIPMENT IS DESIGNED WITH YOUR SAFETY IN MIND. NEVER DISCONNECT AND/OR ATTEMPT TO OVERRIDE SAFETY FEATURES.**

FAILURE TO HEED THESE PRECAUTIONS COULD RESULT IN BODILY INJURY AND/OR PROPERTY DAMAGE.

Note: To help ensure safe operation of this equipment, keep all safety decals clean and legible. Replace safety decals when necessary with new decals, listed in the Parts Section of this manual.

1.2 Description

The HR4000 Series A2 Rear HY-RAIL® guide wheel unit can be applied to the rear of various cab chassis trucks with single or tandem rear axles and dual wheels. The vehicle's G.V.W.R. (gross vehicle weight rating) and/or G.A.W.R. (gross axle weight rating) must comply with specifications recommended by Harsco Rail. For information regarding special applications, contact Harsco Rail, Fairmont, Minnesota.

The guide wheels are raised and lowered hydraulically. Hydraulic power may be supplied from the vehicle system or from an optional power pack. The guide wheel unit is mounted to the vehicle frame. Load bearing guide wheels assemblies guide the vehicle during on track operation. The rear guide wheel unit uses a combination of the guide wheel unit spring suspension and the vehicle suspension to support the load on the rear of the vehicle when on track.

The vehicle's rear inner dual wheels are used for propulsion on the track. On track braking is provided by the vehicle's rear brakes, the front guide wheel unit's brakes and the rear guide wheel unit's brakes, if so equipped. Since the guide wheel unit brakes are air actuated, the vehicle on which the guide wheel equipment is mounted should be equipped with air brakes. If not, an electric / air system is available to provide air for the guide wheel unit brakes.

A steering lock is used during on track operation. The steering lock holds the vehicle's steering wheel in place to ensure the vehicle's front wheels remain in the straight forward portion.

1.3 Vehicle Orientation

Front - rear and left - right are determined from the vehicle operator's seat.

1.4 Serial Numbers

1

When this bulletin is received, complete the following record from the serial number tags on the guide wheel units. Always provide these factory serial numbers when calling or writing about the units. The serial number tag is located on the frame assembly of the units.

FIGURE 1-1
REAR GUIDE WHEEL UNIT SERIAL NUMBER

HARSCO			PATENT NUMBER
			<input type="text"/>
HY-RAIL[®] GUIDE WHEEL EQUIPMENT			WHEN ORDERING PARTS FOR THIS ACCESSORY ALWAYS GIVE THE FOLLOWING INFORMATION
SERIAL NUMBER	SYMBOL	MODEL NUMBER	
<input type="text"/>	<input type="text"/>	<input type="text"/>	
COLUMBIA, S.C. 29171 U.S.A.			02400K

1.5 Specifications

1.5.1 Vehicle

The vehicle's G.V.W.R. (gross vehicle weight rating) and/or G.A.W.R. (gross axle weight rating) must comply with specifications recommended by Harsco Rail. For information regarding special applications, contact Harsco Rail, Fairmont, Minnesota.

1.5.2 Guide Wheel Units

Rear Guide Wheel Unit - Insulated With Side Shift	157712
Rear Guide Wheel Unit - Non-Insulated With Side Shift	158145
Rear Guide Wheel Unit - Insulated Without Side Shift	161282
Rear Guide Wheel Unit - Non-Insulated Without Side Shift	162127
Track Gauge	56-1/2 in (1435 mm)
Guide Wheels - Flange Diameter	18 in (457 mm)
- Tread Diameter	16 in (406 mm)
Weight	
Rear Guide Wheel Unit With Side Shift	1,500 lbs (680 kg)
Rear Guide Wheel Unit Without Side Shift	1,186 lbs (538 kg)
Maximum Load Capacity	
Rear Guide Wheel Unit	20,000 lbs (9,072 kg)
Maximum Load Per Guide Wheel	10,000 lbs (4,536 kg)



SECTION 2 - OPERATION
TABLE OF CONTENTS

2.1 Preparing Vehicle For Operation2 - 3

2.2 Preparing Guide Wheel Equipment For Operation.....2 - 3

2.3 Misalignment Indicators2 - 4

2.4 Placing Vehicle On Track2 - 4

2.4.1 Lowering Rear Guide Wheels2 - 6

2.4.2 Lower Front Guide Wheels2 - 7

2.4.3 Steering Locks2 - 8

2.4.4 Rail Brakes2 - 9

2.5 Guide Wheel Load On Track2 - 9

2.5.5 Checking Rear Guide Wheel Load2 - 10

2.6 Propelling On Track2 - 12

2.7 Braking On Track2 - 13

2.8 Vehicles Equipped With Crane Or Aerial Lift Device2 - 14

2.9 Removing Vehicle From Track2 - 15

2.9.1 Raising Front Guide Wheels2 - 16

2.9.2 Raising Rear Guide Wheels2 - 16

2.9.3 Steering Locks2 - 18

2.10 Highway Operation.....2 - 18

2.11 Towing Trailer / Equipment With Vehicle On Track.....2 - 19

2.12 Towing Trailer / Equipment With Vehicle On Road.....2 - 22

2.13 Towing Disabled Vehicle On Track.....2 - 25

2.14 Towing Disabled Vehicle On Road.....2 - 28

2.1 Preparing Vehicle for Operation

Be sure the vehicle is in operating condition by checking the following:

- a. Engine oil level.
- b. Radiator fluid level.
- c. Fuel tank level.
- d. Hydraulic reservoir oil level.
- e. Brakes work properly.
- f. Parking brake works properly.
- g. Head, brake and signal lights work properly.
- h. Tires properly inflated to the manufacturer's recommended maximum pressure printed on the sidewall of the tires, or the wheel manufacturer's recommended maximum pressure stamped on the wheel, whichever is lower.
- i. Vehicle wheels: Lug nuts / bolts tightened to the proper torque, inspect vehicle wheels, lug bolts and lug nuts for wear or damage. For vehicle wheel, lug bolt and lug nut inspection information refer to the AMERICAN TRUCKING ASSOCIATION - TECHNOLOGY & MAINTENANCE COUNCIL - USER'S GUIDE TO WHEELS AND RIMS. To obtain this guide, contact:

AMERICAN TRUCKING ASSOCIATION
TECHNOLOGY & MAINTENANCE COUNCIL
950 N Glebe Rd., Suite 210
Arlington, VA 22203-4181
Phone: (703) 838-1763
Fax: (703) 838-1701
tmc@trucking.org

- j. Any other normal maintenance requirements.

2.2 Preparing Guide Wheel Equipment For Operation

Be sure the guide wheel equipment is in operating condition by checking the following:

- a. Air and hydraulic hoses and fittings for damage, wear or leaks.
- b. Overall for damaged or worn parts.
- c. Properly lubricated at the recommended operating mileage intervals.
- d. Brakes work properly.
- e. Hydraulic pressure properly adjusted.

2.3 Misalignment Indicators



2

- **BEFORE OPERATING A VEHICLE WITH NEWLY INSTALLED GUIDE WHEEL EQUIPMENT ON TRACK, VERIFY THAT THE GUIDE WHEEL EQUIPMENT ALIGNMENT PROCEDURE HAS BEEN COMPLETED. CHECK AND CORRECT ALIGNMENT PROMPTLY IF MISALIGNMENT IS INDICATED. MISALIGNMENT OF GUIDE WHEEL EQUIPMENT COULD RESULT IN DERAILMENT OF VEHICLE AND SEVERE BODILY INJURY.**

The following conditions may indicate that minor adjustments to the guide wheel equipment alignment are necessary. If any of these conditions occur during operation, perform the Track Test, see Adjustment Section - Vehicle Track Test and/or complete the Alignment Procedure, see Adjustment Section - Guide Wheel Equipment Alignment Procedure.

1. Excessive flange or tread wear on any of the rail guide wheels.
2. Vehicle pulls noticeably to the left or the right during on track operation.
3. Vibration felt throughout the vehicle at various speeds during on track operation.

2.4 Placing Vehicle On Track



- **PLACE VEHICLE AUTOMATIC TRANSMISSION IN "PARK" OR MANUAL TRANSMISSION IN "NEUTRAL". APPLY THE PARKING BRAKE.**
- **UNDERSTAND EQUIPMENT OPERATION AND BE AWARE OF ALL PINCH POINTS BEFORE OPERATING OR MAKING ADJUSTMENTS TO GUIDE WHEEL EQUIPMENT.**
- **BEFORE PROPELLING VEHICLE ON THE TRACK, MAKE SURE:**
 - **FRONT AND REAR GUIDE WHEELS ARE LOWERED AND LOCKED IN RAIL POSITION, AND SECURED WITH LOCK PINS.**
 - **ALL RAIL GUIDE WHEEL FLANGES ARE ENGAGED ON INSIDE OF RAIL.**
 - **VEHICLE FRONT TIRES ARE A MINIMUM OF 1-1/2" (38 mm) ABOVE THE RAIL.**
 - **STEERING WHEEL LOCK IS ENGAGED.**
 - **IF EQUIPPED, BRAKE CONTROL VALVE IS IN THE "ON" POSITION AND GUIDE WHEEL BRAKE EQUIPMENT IS FUNCTIONAL.**

FAILURE TO HEED THESE WARNINGS COULD RESULT IN DERAILMENT OF VEHICLE AND SEVERE BODILY INJURY.

2.4 Placing Vehicle On Track



- **WHEN USING VEHICLE MECHANICAL PTO HYDRAULIC PUMP TO LOWER/RAISE GUIDE WHEEL EQUIPMENT, DO NOT EXCEED HYDRAULIC SYSTEM FLOW OF 8 GPM (30 LPM) OR HYDRAULIC PRESSURE OF 2500 PSI (172 bar). EXCESSIVE FLOW AND / OR PRESSURE COULD DAMAGE HYDRAULIC SYSTEM COMPONENTS.**
- **OBSERVE AND FOLLOW ALL RAILROAD SAFETY RULES AND REGULATIONS.**
- **IF THE VEHICLE IS EQUIPPED WITH A STROBE LIGHT (BEACON) AND RAILROAD RULES AND REGULATIONS REQUIRE ITS USE, THE STROBE LIGHT (BEACON) MUST BE ILLUMINATED WHEN PLACING THE VEHICLE ON TRACK AND WHEN OPERATING THE VEHICLE ON TRACK.**

FAILURE TO HEED THESE PRECAUTIONS COULD RESULT IN BODILY INJURY AND/OR PROPERTY DAMAGE.

1. Ensure that highway vehicles are not approaching the grade crossing while placing the vehicle on track. Flag the crossing per railroad rules and regulations to ensure safety.
2. At a road crossing, drive the vehicle about 25 feet (7.6 m) past the track. Back the vehicle onto the rails so that the rear vehicle wheels are centered on the rails. On vehicles with dual rear wheels, the inner dual wheels must be centered on the rails. It may be necessary to move the vehicle back and forth several times to get the wheels centered on the rail properly.
3. Place the vehicle automatic transmission in "PARK" or manual transmission in "NEUTRAL". Apply the parking brake.
4. Engage the mechanical PTO hydraulic pump or start the auxiliary hydraulic power source. If the vehicle is equipped with an auxiliary control valve, place the valve in the proper position to direct hydraulic oil flow to the guide wheel equipment.

2.4 Placing Vehicle On Track

2.4.1 Lowering Rear Guide Wheels - See Figure 2-1

1. Lower and lock the rear guide wheels first. The rear guide wheels should be lowered first so the front tires of the vehicle can be maneuvered to align the front guide wheels with the rails.
2. Remove lock pin (1). Button in "T" end of the pin must be pressed in to remove the pin.
3. Raise the guide wheel unit slightly by pulling control valve handle (2) out to release pressure on the mechanical lock mechanism.
4. Rotate and hold lock handle (3) clockwise to release the locking mechanism. While holding lock handle (3) in a released position, push control valve handle (2) in to lower the guide wheels.
5. If the guide wheel unit is equipped with side shift, the guide wheel axle can be shifted to align the guide wheels with the rail. Push control valve handle (4) in to shift the guide wheels to the right. Pull control valve handle (4) out to shift the guide wheels to the left. After shifting the guide wheels to align with the rail, continue to lower the guide wheels.
6. As the guide wheels lower, release lock handle (3). Continue to lower the guide wheels until the wheel flanges are engaged on the inside of the rail. Release control valve handle (2). The side shift self-centering mechanism will bring the vehicle into alignment with the rails.
7. Install lock pin (1) through the hole in the lock handle and the guide wheel unit frame to secure the mechanical lock.

2.4 Placing Vehicle On Track

2.4.1 Lowering Rear Guide Wheels

FIGURE 2-1
LOWERING REAR GUIDE WHEELS

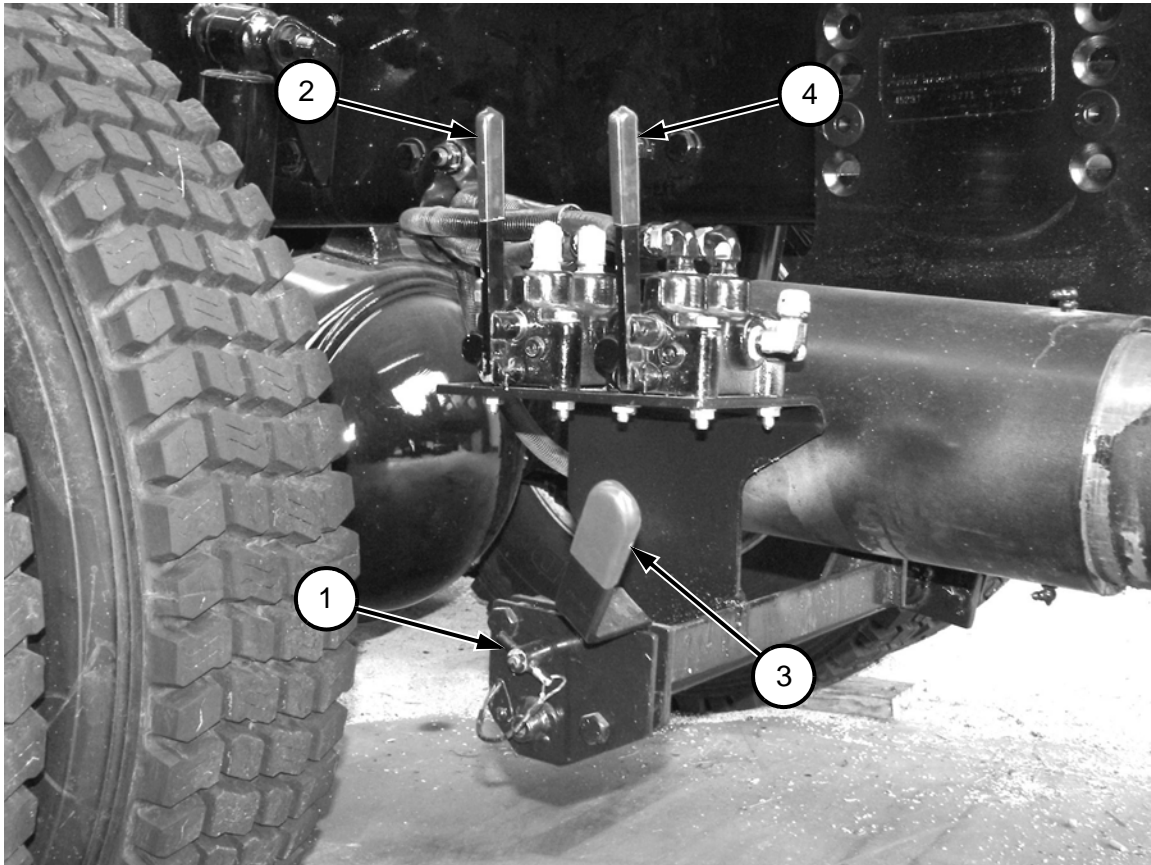

2.4.2 Lowering Front Guide Wheels

1. Lower the front guide wheels. See the Operator's Service And Parts Manual provided with the front guide wheel unit for the procedure to lower the front guide wheels.
2. Disengage the mechanical PTO hydraulic pump or stop the auxiliary hydraulic power source. If the vehicle is equipped with an auxiliary control valve, place the valve in the proper position to shut off hydraulic oil flow to the guide wheel equipment.

2.4 Placing Vehicle On Track

2.4.3 Steering Locks - See Figures 2-2, 2-3, 2-4 and 2-5

Set the vehicle front wheels straight ahead and secure the steering wheel in that position by engaging the steering lock on the steering column. Steering locks may vary from vehicle to vehicle but will operate similarly.

2

Note: Do not place your hands or any pressure on the steering wheel after the steering lock is engaged.

FIGURE 2-2
VELCRO STEERING LOCK OFF

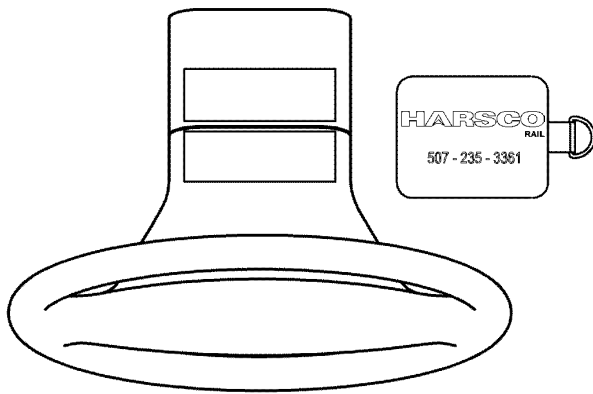

FIGURE 2-3
VELCRO STEERING LOCK ON

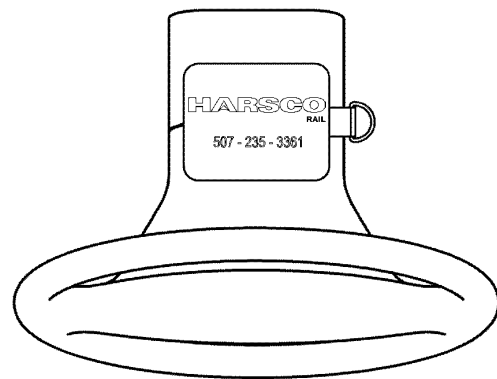

FIGURE 2-4
DEAD BOLT TYPE
STEERING LOCK DISENGAGED

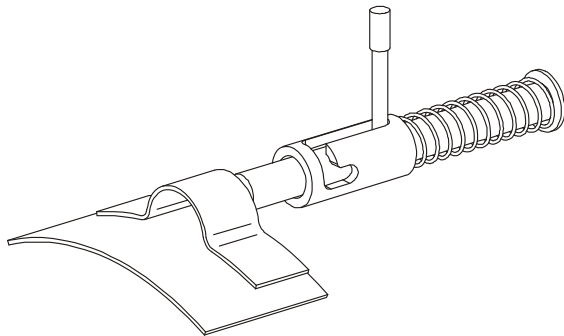
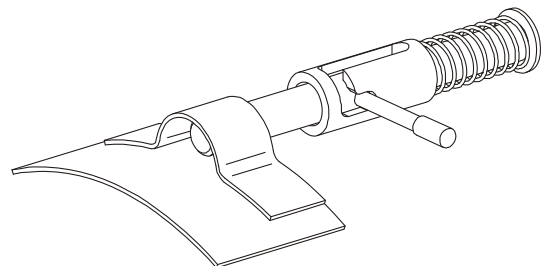

FIGURE 2-5
DEAD BOLT TYPE
STEERING LOCK ENGAGED



2.4.4 Rail Brakes

If so equipped, move the Rail Wheel Brake Control Valve to the ON position to activate the guide wheel equipment brakes whenever the vehicle is on track. The vehicle brake pedal will actuate the vehicle brakes and the guide wheel equipment brakes simultaneously.

2.5 Guide Wheel Load On Track



- **IMPROPER LOADING OF GUIDE WHEEL EQUIPMENT CAN CAUSE DERAILMENT OF VEHICLE.**
- **ALWAYS CHECK THE GUIDE WHEEL LOAD BEFORE OPERATING THE VEHICLE ON TRACK.**
- **NEVER OPERATE THE VEHICLE ON TRACK IF LOAD EXCEEDS THE MAXIMUM RATED LOAD OF THE FRONT AND/OR REAR GUIDE WHEEL UNITS. THE MAXIMUM LOAD ON THE REAR GUIDE WHEEL UNIT IS 20,000 LBS (9,072 kg) OR 10,000 LBS (4,536 kg) MAXIMUM PER GUIDE WHEEL.**
- **NEVER OPERATE THE VEHICLE ON TRACK IF CLEARANCE BETWEEN VEHICLE FRONT TIRES AND RAIL IS LESS THAN 1-1/2" (38 mm).**

FAILURE TO HEED THESE WARNINGS COULD RESULT IN DERAILMENT OF VEHICLE AND/OR SEVERE BODILY INJURY.

Whenever the vehicle is loaded or additional load is added to the existing vehicle load on track, check the load on the front and rear guide wheels. The maximum load on the rear guide wheel unit is 20,000 lbs (9,072 kg) or 10,000 lbs (4,536 kg) maximum per guide wheel.

2.5 Guide Wheel Load On Track

2.5.1 Checking Rear Guide Wheel Load - See Figures 2-6 and 2-7

1. Apply the parking brake. Stop the vehicle's engine.
2. The protrusion of rod (1) on the spring cell is used to determine the load on the rear guide wheels. Measure dimension "X" on both spring cells. See Figure 2-7 to convert dimension "X" to the spring cell load.
3. The minimum rated load capacity of the rear guide wheel unit is 33% of the vehicle's rear axle curb weight, or at least 3,650 lbs (1656 kg) total or 1,825 lbs (828 kg) per guide wheel.

If the measured rear guide wheel load does not meet the minimum rated load capacity of the rear guide wheel unit, total or per guide wheel, the rear guide wheel unit load must be re-adjusted. See Adjustments - Guide Wheel Alignment Procedure. Never operate the vehicle on track if the measured load on the rear guide wheel unit does not meet the minimum rated load capacity of 3,650 lbs (1656 kg) total or 1,825 lbs (828 kg) per guide wheel.

4. The maximum rated load capacity of the rear guide wheel unit is 20,000 lbs (9,072 kg) or 10,000 lbs (4,536 kg) maximum per guide wheel.

If the measured rear guide wheel load does not exceed the maximum rated load capacity of the rear guide wheel unit, total or per guide wheel, the load on the rear guide wheel is acceptable.

If the measured rear guide wheel load does exceed the maximum rated load capacity of the rear guide wheel unit, total or per guide wheel, the vehicle load must be redistributed or some of the load removed. Never operate the vehicle on track if the measured load on the rear guide wheel unit exceeds the maximum rated load capacity of 20,000 lbs (9,072 kg) or 10,000 lbs (4,536 kg) maximum per guide wheel.

FIGURE 2-6
MEASURING REAR SPRING CELL

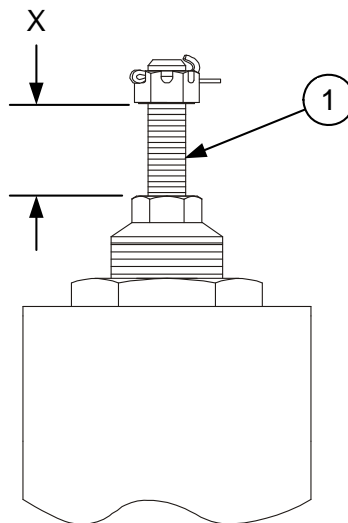

2.5 Guide Wheel Load On Track

2.5.1 Checking Rear Guide Wheel Load

FIGURE 2-7
REAR GUIDE WHEEL LOAD CHART

DIMENSION X		APPROXIMATE LOAD PER SIDE	
1/2"	12.7 mm	1,660 lbs	744 kg
3/4"	19.1 mm	2,380 lbs	1,080 kg
1"	25.4 mm	3,110 lbs	1,411 kg
1-1/4"	31.8 mm	3,840 lbs	1,742 kg
1-1/2"	38.1 mm	4,580 lbs	2,077 kg
1-3/4"	44.5 mm	5,310 lbs	2,409 kg
2"	50.8 mm	6,050 lbs	2,744 kg
2-1/4"	57.2 mm	6,750 lbs	3,062 kg
2-1/2"	63.5 mm	7,510 lbs	3,407 kg
2-3/4"	69.9 mm	8,250 lbs	3,742 kg
3"	76.2 mm	8,980 lbs	4,073 kg
3-1/4"	82.6 mm	9,710 lbs	4,404 kg
* 3-1/2"	88.9 mm	10,400 lbs	4,717 kg

* REAR GUIDE WHEEL UNIT IS OVERLOADED. REDISTRIBUTE OR REMOVE SOME OF THE LOAD. MAXIMUM LOAD ON REAR GUIDE WHEEL UNIT MUST NOT EXCEED 20,000 LBS (9,072 kg) OR 10,000 LBS (4,536kg) MAXIMUM PER GUIDE WHEEL.

2.6 Propelling On Track



2

- **IMPROPER LOADING OF HY-RAIL® EQUIPPED VEHICLE CAN CAUSE DERAILMENT OF VEHICLE.**
- **ALWAYS CHECK GUIDE WHEEL LOAD BEFORE OPERATING THE VEHICLE ON TRACK.**
- **NEVER OPERATE VEHICLE ON TRACK IF LOAD EXCEEDS MAXIMUM RATED LOAD OF FRONT AND/OR REAR GUIDE WHEEL UNITS.**
- **NEVER OPERATE VEHICLE ON TRACK IF CLEARANCE BETWEEN VEHICLE FRONT TIRE AND RAIL IS LESS THAN 1-1/2" (38 mm).**

FAILURE TO HEED THESE WARNINGS COULD RESULT IN DERAILMENT OF VEHICLE AND/OR SEVERE BODILY INJURY.



- **BEFORE OR WHEN PROPELLING ON TRACK:**
 - **OBSERVE AND FOLLOW ALL RAILROAD SAFETY RULES AND REGULATIONS.**
 - **OPERATOR MUST LOOK IN ALL DIRECTIONS FOR PERSONS OR OBJECTS ON OR ADJACENT TO THE TRACK.**
 - **DO NOT ACCELERATE SUDDENLY. TRACTION IS REDUCED ON TRACK, SPINNING VEHICLE TIRES COULD DAMAGE THEM.**
 - **DO NOT EXCEED 25 MPH (40 km/h) WHEN OPERATING VEHICLE ON TRACK. RAILROAD RULES GOVERNING SPEEDS SHOULD BE OBSERVED AT ALL TIMES. REDUCE SPEED WHEN PROPELLING VEHICLE THROUGH SWITCHES, ROAD CROSSINGS, BRANCH LINES AND ANY SPECIAL TRACK WORKS. OPERATING VEHICLE AT UNSAFE SPEEDS COULD RESULT IN DERAILMENT OF THE VEHICLE.**
 - **STEERING LOCK MUST BE ENGAGED AT ALL TIMES WHEN OPERATING VEHICLE ON TRACK.**
 - **IF THE VEHICLE IS EQUIPPED WITH A STROBE LIGHT (BEACON) AND RAILROAD RULES AND REGULATIONS REQUIRE ITS USE, THE STROBE LIGHT (BEACON) MUST BE ILLUMINATED WHEN OPERATING THE VEHICLE ON TRACK.**

FAILURE TO HEED THESE PRECAUTIONS COULD RESULT IN BODILY INJURY AND/OR PROPERTY DAMAGE.

Vehicles equipped with the HR4000 Series A2 HY-RAIL® Guide Wheel Equipment use the vehicle propulsion system to propel on track. Do not accelerate suddenly. Traction is reduced on track. Spinning the vehicle tires could damage them.

2.7 Braking On Track



- PERSONS WHO OPERATE THE VEHICLE MUST BE FAMILIAR WITH TRACK AND WEATHER CONDITIONS THAT MAY AFFECT STOPPING DISTANCE. BE ALERT TO THESE CONDITIONS AND ALLOW ADEQUATE STOPPING DISTANCE.
- BE PREPARED TO BRAKE AT ALL HIGHWAY CROSSINGS. THIS VEHICLE MAY NOT OPERATE TRACK SIGNAL CIRCUITS, AND ONCOMING VEHICLES OR PEDESTRIANS MAY NOT YIELD THE RIGHT OF WAY.
- IF EQUIPPED, RAIL WHEEL BRAKE CONTROL VALVE MUST BE IN THE "ON" POSITION WHENEVER VEHICLE IS ON TRACK.

FAILURE TO HEED THESE PRECAUTIONS COULD RESULT IN BODILY INJURY AND/OR PROPERTY DAMAGE.

The HR4000 Series A2 HY-RAIL® Guide Wheel Equipment may be equipped with brakes. If the guide wheel unit is equipped with brakes, the vehicle uses a combination of the guide wheel unit brakes and the vehicle's rear axle brake system for braking on track. The guide wheel unit brakes will apply simultaneously when the vehicle brakes are applied. Stopping distance is greater on track than on typical road surfaces. Apply the brakes gradually to avoid sliding the vehicle tires and rail guide wheels.

2.8 Vehicles Equipped With Crane Or Aerial Lift Device



2

- **WHEN OPERATING CRANE, AERIAL LIFT DEVICE, ETC., WHILE THE VEHICLE'S GUIDE WHEELS ARE ON THE RAILS, DO NOT OVERLOAD THE GUIDE WHEEL EQUIPMENT OR EXCEED THE CAPACITY OF ANY OF THE EQUIPMENT BEING USED.**
- **THE UNIT SHOULD BE EQUIPPED WITH OUTRIGGERS TO HELP PREVENT ACCIDENTS AND THE POSSIBILITY OF DAMAGE TO THE GUIDE WHEEL EQUIPMENT. WHEN USING THE EQUIPMENT TO TRANSFER ANY LOAD, SET THE OUTRIGGERS ON A STABLE BASE TO PREVENT SETTLING OF THE OUTRIGGERS AND SHIFTING OF THE VEHICLE.**
- **IF OPERATING CONDITIONS REQUIRE LIFTING A LOAD WITH THE CRANE WHILE ON RAIL, BUT WITHOUT THE OUTRIGGERS BEING USED, THE LOAD APPLIED BY LIFTING WITH THE CRANE MUST NOT OVERLOAD ANY COMPONENT OF THE GUIDE WHEEL EQUIPMENT.**
- **CAREFULLY READ THE CRANE OR AERIAL LIFT DEVICE OPERATOR'S MANUAL FOR THE SAFE USE AND EFFICIENT OPERATION OF THE EQUIPMENT.**

FAILURE TO HEED THESE WARNINGS COULD CAUSE DERAILMENT OF THE VEHICLE RESULTING IN SEVERE BODILY INJURY AND/OR DEATH.

1. When operating a crane, aerial lift device, etc., while the vehicle's guide wheels are on the rails, do not overload the guide wheel equipment or exceed the capacity of any of the equipment being used.
2. The crane, aerial lift device, etc. should be equipped with outriggers to help prevent accidents and the possibility of damage to the guide wheel equipment. When using the crane, aerial lift device, etc. to transfer any load, set the outriggers on a stable base to prevent settling of the outriggers and shifting of the vehicle. Carefully read the crane or aerial lift equipment operator's manual for the safe use and efficient operation of the equipment.
3. If operating conditions require lifting a load with the crane while on rail, but without the outriggers being used, the load applied by lifting with the crane must not overload any component of the guide wheel equipment.

2.9 Removing Vehicle From Track



- PLACE VEHICLE AUTOMATIC TRANSMISSION IN "PARK" OR MANUAL TRANSMISSION IN "NEUTRAL". APPLY THE PARKING BRAKE.
- UNDERSTAND EQUIPMENT OPERATION AND BE AWARE OF ALL PINCH POINTS BEFORE OPERATING OR MAKING ADJUSTMENTS TO GUIDE WHEEL EQUIPMENT.
- BEFORE PROPELLING VEHICLE OFF TRACK, MAKE SURE:
 - FRONT AND REAR GUIDE WHEELS ARE RAISED, LOCKED IN THE HIGHWAY POSITION, AND SECURED WITH THE LOCK PINS.
 - STEERING WHEEL LOCK IS DISENGAGED.

FAILURE TO HEED THESE WARNINGS COULD RESULT IN SEVERE BODILY INJURY.



- WHEN USING VEHICLE MECHANICAL PTO HYDRAULIC PUMP TO LOWER/RAISE GUIDE WHEEL EQUIPMENT, DO NOT EXCEED HYDRAULIC SYSTEM FLOW OF 8 GPM (30 LPM) OR HYDRAULIC PRESSURE OF 2500 PSI (172 bar). EXCESSIVE FLOW AND / OR PRESSURE COULD DAMAGE HYDRAULIC SYSTEM COMPONENTS.
- OBSERVE AND FOLLOW ALL RAILROAD SAFETY RULES AND REGULATIONS.
- IF THE VEHICLE IS EQUIPPED WITH A STROBE LIGHT (BEACON) AND RAILROAD RULES AND REGULATIONS REQUIRE ITS USE, THE STROBE LIGHT (BEACON) MUST BE ILLUMINATED WHEN OPERATING AND REMOVING THE VEHICLE FROM TRACK.

FAILURE TO HEED THESE PRECAUTIONS COULD RESULT IN BODILY INJURY AND/OR PROPERTY DAMAGE.

1. Ensure that highway vehicles are not approaching the grade crossing while removing the vehicle from the track. Flag the crossing per railroad rules and regulations to ensure safety.
2. Approach the crossing and stop with the vehicle front wheels on the crossing.
3. Place the vehicle automatic transmission in "PARK" or manual transmission in "NEUTRAL". Apply the parking brake.
4. If so equipped, move the Rail Wheel Brake Control Valve to the OFF position, whenever the vehicle is removed from the track for highway use.
5. Engage the mechanical PTO hydraulic pump or start the auxiliary hydraulic power source. If the vehicle is equipped with an auxiliary control valve, place the valve in the proper position to direct hydraulic oil flow to the guide wheel equipment.

2.9 Removing Vehicle From Track

2.9.1 Raising Front Guide Wheels

1. Raise the front guide wheel unit first. See the Operator's Service And Parts Manual provided with the front guide wheel unit for the procedure to raise the front guide wheels.

2

2.9.2 Raising Rear Guide Wheels - See Figure 2-8

1. Remove lock pin (1).
2. Push control valve handle (2) towards the vehicle to release pressure on the mechanical lock mechanism.
3. Rotate and hold lock handle (3) counter-clockwise to release the locking mechanism. While holding lock handle (3), pull control valve handle (2) away from the vehicle to raise the guide wheels.
4. As the guide wheels raise, release lock handle (3). Continue to raise the guide wheel unit until it is in the "highway" position. Release control valve handle (2).
5. Install lock pin (1) through the hole in the lock handle and the guide wheel unit frame to secure the mechanical lock.
6. Disengage the mechanical PTO hydraulic pump or stop the auxiliary hydraulic power source. If the vehicle is equipped with an auxiliary control valve, place the valve in the proper position to shut off hydraulic oil flow to the guide wheel equipment.

2.9 Removing Vehicle From Track

2.9.2 Raising Rear Guide Wheels

FIGURE 2-8
RAISING REAR GUIDE WHEELS

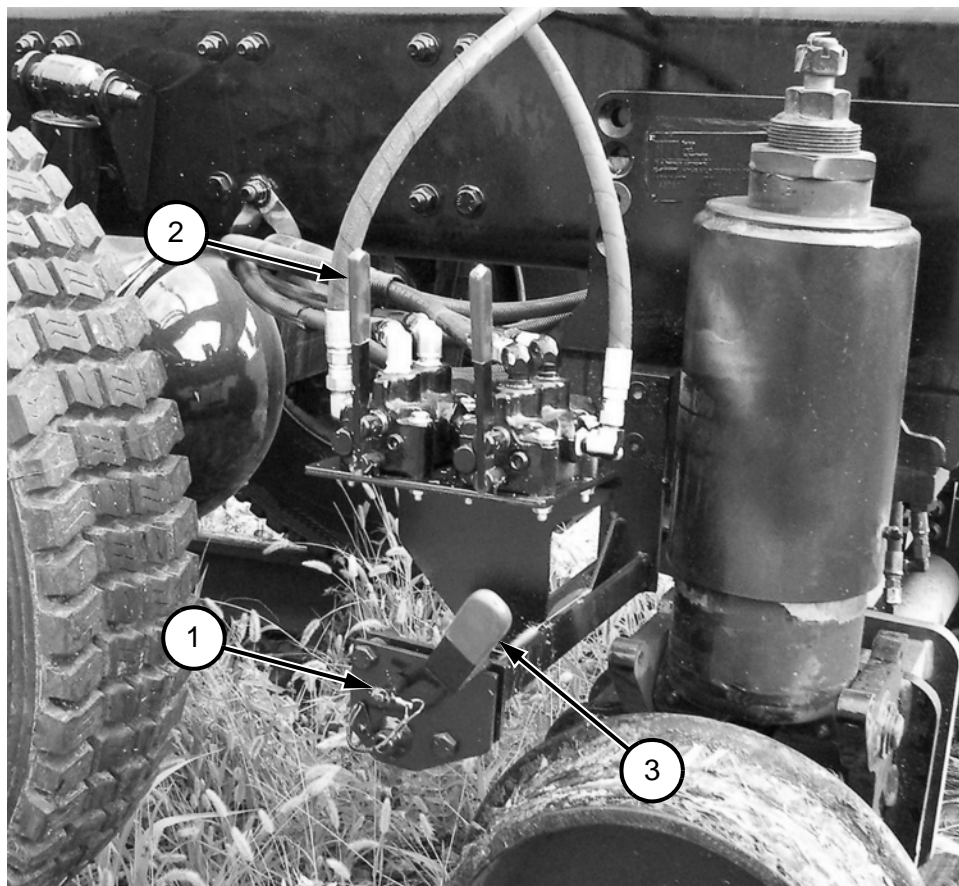

2.9 Removing Vehicle From Track

2.9.3 Steering Locks - See Figures 2-9, 2-10, 2-11 and 2-12

- 1 Disengage the vehicle steering lock located on the steering column. Steering locks may vary from vehicle to vehicle but will operate similarly.

2

FIGURE 2-9
VELCRO STEERING LOCK OFF

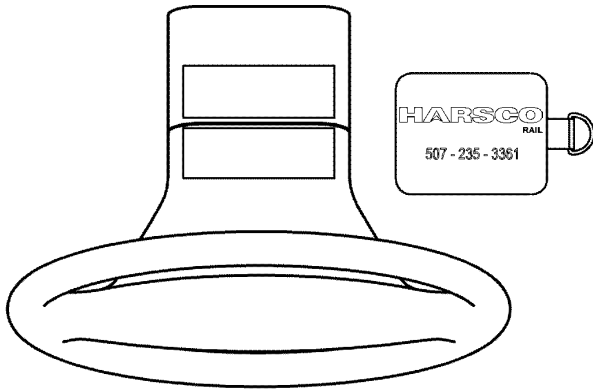

FIGURE 2-10
VELCRO STEERING LOCK ON

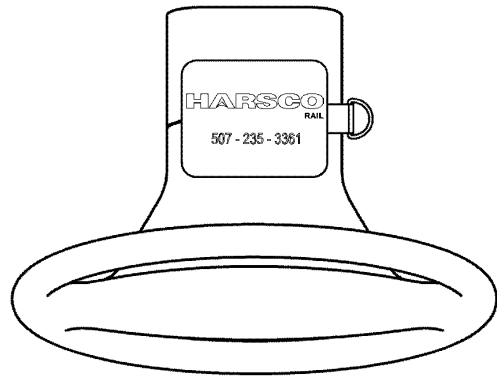

FIGURE 2-11
DEAD BOLT TYPE
STEERING LOCK DISENGAGED

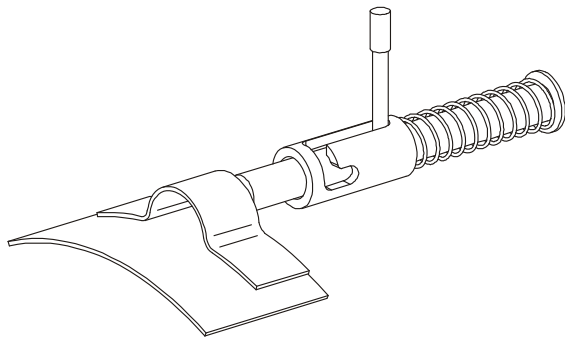
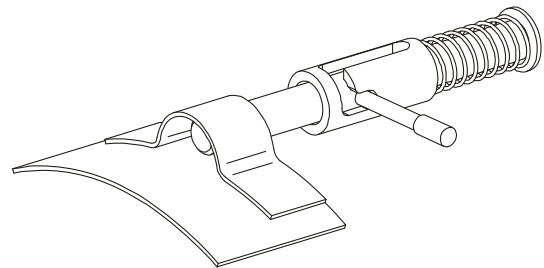

FIGURE 2-12
DEAD BOLT TYPE
STEERING LOCK ENGAGED



2.10 Highway Operation



- **THIS MULTIPURPOSE VEHICLE HAS SPECIAL DESIGN AND EQUIPMENT FEATURES FOR OFF-ROAD USE. IT HANDLES DIFFERENTLY FROM AN ORDINARY PASSENGER CAR IN DRIVING CONDITIONS WHICH MAY OCCUR ON STREETS, HIGHWAYS AND OFF-ROAD. WEIGHT AND LOCATION OF AVAILABLE PAYLOAD MAY ALSO AFFECT THE HANDLING OF THIS VEHICLE. DRIVE WITH CARE AND WEAR SAFETY BELTS AT ALL TIMES. READ VEHICLE OWNER'S MANUAL FOR ADDITIONAL PRECAUTIONS.**

2.11 Towing Trailer / Equipment With Vehicle On Track



- VEHICLE USED FOR TOWING MUST BE RATED BY VEHICLE MANUFACTURER FOR WEIGHT OF TRAILER / EQUIPMENT TO BE TOWED. DO NOT EXCEED VEHICLE MANUFACTURER'S MAXIMUM RATED TOWING CAPACITY.
- TOWING VEHICLE MUST WEIGH AS MUCH OR MORE THAN TRAILER / EQUIPMENT BEING TOWED.
- VEHICLE USED FOR TOWING MUST HAVE AN ADEQUATE BRAKE SYSTEM TO SAFELY DECELERATE AND STOP TOWING VEHICLE AND TRAILER / EQUIPMENT BEING TOWED.
- TOWING TRAILER / EQUIPMENT LENGTHENS STOPPING DISTANCES. ALLOW ADEQUATE DISTANCE FOR STOPPING. ANTICIPATE STOPS SO YOU CAN BRAKE GRADUALLY.
- STOPPING DISTANCE IS GREATER ON TRACK THAN ON TYPICAL ROAD SURFACES. APPLY BRAKES GRADUALLY TO AVOID SLIDING VEHICLE TIRES AND GUIDE WHEELS.
- TOW TRAILER / EQUIPMENT AT A REASONABLE SPEED (20 MPH MAXIMUM) TAKING INTO ACCOUNT TRACK CONDITIONS, TRACK GRADE, WEATHER, VISIBILITY AND STOPPING DISTANCE TO ASSURE SAFE OPERATION. RAILROAD RULES GOVERNING SPEEDS AND RIGHT OF WAY SHOULD BE OBSERVED AT ALL TIMES.
- TRAILER / EQUIPMENT BEING TOWED MUST BE IN A SAFE, USABLE CONDITION TO BE TOWED.
- MAKE SURE THAT VEHICLE'S:
 - FRONT AND REAR GUIDE WHEEL ARE LOWERED AND LOCKED IN THE RAIL POSITION.
 - ALL GUIDE WHEEL FLANGES ARE ENGAGED ON INSIDE OF RAILS.
 - FRONT TIRES ARE A MINIMUM OF 1-1/2" (38 mm) ABOVE RAIL.
 - VEHICLE STEERING WHEEL LOCK ENGAGED WITH FRONT WHEELS STRAIGHT AHEAD.

FAILURE TO HEED THESE WARNINGS COULD RESULT IN SEVERE BODILY INJURY.

2.11 Towing Trailer / Equipment With Vehicle On Track



2

- CAREFULLY AND THOROUGHLY PREPARE VEHICLE FOR TOWING, MAKING SURE TO USE THE RIGHT TOWING EQUIPMENT AND TO ATTACH IT PROPERLY.
- TOWING EQUIPMENT (HITCHES, TOW BARS, ETC.) MUST BE ATTACHED TO VEHICLE FRAME. DO NOT MOUNT OR ATTACH TOWING EQUIPMENT TO VEHICLE'S GUIDE WHEEL EQUIPMENT.
- TOWING EQUIPMENT (HITCHES, TOW BARS, ETC.) MUST HAVE A RATED TOWING CAPACITY EQUAL TO OR GREATER THAN WEIGHT OF TRAILER / EQUIPMENT BEING TOWED.
- USE A RIGID TYPE TOW BAR WITH SAFETY LOCKING COUPLERS. DO NOT USE CHAIN, WIRE ROPE ETC.
- OBSERVE AND FOLLOW ALL RAILROAD SAFETY RULES AND REGULATIONS.
- DO NOT ACCELERATE SUDDENLY. TRACTION IS REDUCED ON RAIL, SPINNING VEHICLE TIRES COULD DAMAGE THEM.
- ALWAYS CHOCK TRAILER WHEELS BEFORE UNHOOKING TRAILER FROM TOWING VEHICLE.
- FAILURE TO HEED THESE PRECAUTIONS COULD RESULT IN BODILY INJURY AND/OR PROPERTY DAMAGE.

2.11 Towing Trailer / Equipment With Vehicle On Track

1. See your vehicle's operators manual for towing information.
2. Use the vehicle manufacturer's recommendations to determine the maximum weight the towing vehicle can tow. Do not exceed vehicle manufacturer's maximum rated towing capacity.
3. The towing vehicle must have an adequate brake system to safely decelerate and stop the towing vehicle and the trailer / equipment being towed. The towing vehicle must weigh as much or more than the trailer / equipment being towed.
4. Make sure that the vehicle's:
 - a. Front and rear guide wheels are lowered and locked in the rail position.
 - b. All guide wheel flanges are engaged on the inside of the rails.
 - c. Front tires are a minimum of 1-1/2" (38 mm) above the rail.
 - d. Vehicle front wheels are set straight ahead and the steering wheel lock is engaged on the steering column.
5. Make sure the towing vehicle and the trailer / equipment are in good working condition (tires, brakes, lights, etc.) and that current maintenance has been performed on the vehicle and trailer / equipment.
6. The towing equipment (hitches, tow bars, etc.) on the towing vehicle must have a rating equal to or greater than the weight of the trailer / equipment being towed.
7. The towing equipment (hitches, tow bars, etc.) must be attached to the towing vehicle frame. Do not mount or attach the towing equipment to the vehicle's guide wheel equipment.
8. Observe and follow all railroad safety rules and regulations.
9. Do not accelerate suddenly. Traction is reduced on rail. Spinning the vehicle tires could damage them.
10. Stopping distance is greater on rail than on typical road surfaces. Apply the vehicle brakes gradually to avoid sliding the vehicle tires and the guide wheels. Towing trailer / equipment lengthens stopping distances. Allow adequate distance for stopping. Anticipate stops so that you can brake gradually.
11. Tow the trailer / equipment on the track at a reasonable speed (20 MPH maximum) taking into account track conditions, track grade, weather, visibility and stopping distance to assure safe operation. Railroad rules and regulations governing speed limits and right of way should be observed at all times.
12. Always chock the trailer wheels before unhooking the trailer from the towing vehicle.

2.12 Towing Trailer / Equipment With Vehicle On Road



2

- VEHICLE USED FOR TOWING MUST BE RATED BY VEHICLE MANUFACTURER FOR WEIGHT OF TRAILER / EQUIPMENT TO BE TOWED. DO NOT EXCEED VEHICLE MANUFACTURER'S MAXIMUM RATED TOWING CAPACITY.
- VEHICLE USED FOR TOWING MUST HAVE AN ADEQUATE BRAKE SYSTEM TO SAFELY DECELERATE AND STOP TOWING VEHICLE AND TRAILER / EQUIPMENT BEING TOWED.
- TOWING TRAILER / EQUIPMENT LENGTHENS STOPPING DISTANCES. ALLOW ADEQUATE DISTANCE FOR STOPPING. ANTICIPATE STOPS SO YOU CAN BRAKE GRADUALLY.
- TOW TRAILER / EQUIPMENT AT A REASONABLE SPEED TAKING INTO ACCOUNT ROAD CONDITIONS, ROAD GRADE, WEATHER, VISIBILITY AND STOPPING DISTANCE TO ASSURE SAFE OPERATION. POSTED SPEED LIMITS SHOULD BE OBSERVED AT ALL TIMES.
- TRAILER / EQUIPMENT BEING TOWED MUST BE IN A SAFE, USABLE CONDITION TO BE TOWED.
- MAKE SURE THAT VEHICLE'S:
 - FRONT AND REAR GUIDE WHEELS ARE RAISED AND LOCKED IN HIGHWAY POSITION.
 - VEHICLE STEERING WHEEL LOCK DISENGAGED.

FAILURE TO HEED THESE WARNINGS COULD RESULT IN SEVERE BODILY INJURY.

2.12 Towing Trailer / Equipment With Vehicle On Road



- THIS MULTIPURPOSE VEHICLE HAS SPECIAL DESIGN AND EQUIPMENT FEATURES FOR OFF-ROAD USE. IT HANDLES DIFFERENTLY FROM AN ORDINARY PASSENGER CAR IN DRIVING CONDITIONS WHICH MAY OCCUR ON STREETS, HIGHWAYS AND OFF-ROAD. WEIGHT AND LOCATION OF AVAILABLE PAYLOAD MAY ALSO AFFECT THE HANDLING OF THIS VEHICLE. DRIVE WITH CARE AND WEAR SAFETY BELTS AT ALL TIMES. READ VEHICLE OWNER'S MANUAL FOR ADDITIONAL PRECAUTIONS.
- OBSERVE AND FOLLOW ALL FEDERAL, STATE AND LOCAL DRIVING RULES AND REGULATIONS.
- STATE LAWS MAY REQUIRE TOWING VEHICLE AND TRAILER / EQUIPMENT BEING TOWED TO BE EQUIPPED WITH SPECIAL SAFETY EQUIPMENT (MIRRORS ON BOTH SIDES OF TOWING VEHICLE, TRAILER BRAKES, TRAILER LIGHTS, ETC.).
- CAREFULLY AND THOROUGHLY PREPARE YOUR VEHICLE FOR TOWING, MAKING SURE TO USE THE RIGHT TOWING EQUIPMENT AND TO ATTACH IT PROPERLY.
- TOWING EQUIPMENT (HITCHES, TOW BARS, ETC.) MUST BE ATTACHED TO VEHICLE FRAME. DO NOT MOUNT OR ATTACH TOWING EQUIPMENT TO VEHICLE'S GUIDE WHEEL EQUIPMENT.
- TOWING EQUIPMENT (HITCH, TOW BAR, ETC.) MUST HAVE A RATED TOWING CAPACITY EQUAL TO OR GREATER THAN WEIGHT OF TRAILER / EQUIPMENT BEING TOWED.
- ALWAYS CHOCK TRAILER WHEELS BEFORE UNHOOKING TRAILER FROM TOWING VEHICLE.
- FAILURE TO HEED THESE PRECAUTIONS COULD RESULT IN BODILY INJURY AND/OR PROPERTY DAMAGE.

2.12 Towing Trailer / Equipment With Vehicle On Road

1. See your vehicle's operators manual for towing information.
2. Use the vehicle manufacturer's recommendations to determine the maximum weight the towing vehicle can tow. Do not exceed vehicle manufacturer's maximum rated towing capacity.
3. The towing vehicle must have an adequate brake system to safely decelerate and stop the towing vehicle and the trailer / equipment being towed. Towing trailer / equipment lengthens stopping distances. Allow adequate distance for stopping. Anticipate stops so that you can brake gradually.
4. Make sure that the vehicle's:
 - a. Front and rear guide wheels are raised and locked in the highway position.
 - b. Vehicle steering wheel lock is disengaged on the steering column.
5. Make sure the towing vehicle and the trailer / equipment are in good working condition (tires, brakes, lights, etc.) and that current maintenance has been performed on the vehicle and trailer / equipment.
6. The towing equipment (hitches, tow bars, etc.) on the towing vehicle must have a rating equal to or greater than the weight of the trailer / equipment being towed.
7. The towing equipment (hitches, tow bars, etc.) must be attached to the towing vehicle frame. Do not mount or attach the towing equipment to the vehicle's guide wheel equipment.
8. Observe and follow all federal, state and local driving rules, regulations and laws.
9. State laws may require the towing vehicle and/or the trailer / equipment being towed to be equipped with special safety equipment (mirrors on both sides of the towing vehicle, trailer brakes, trailer lights, etc.).
10. Tow the trailer / equipment on the road at a reasonable speed taking into account road conditions, road grade, weather, visibility and stopping distance to assure safe operation. Always observe posted speed limits.
11. Always chock the trailer wheels before unhooking the trailer from the towing vehicle.

2.13 Towing Disabled Vehicle On Track



- TOWING VEHICLE / MACHINE MUST WEIGH AS MUCH OR MORE THAN DISABLED VEHICLE BEING TOWED.
- VEHICLE / MACHINE USED FOR TOWING MUST HAVE AN ADEQUATE BRAKE SYSTEM TO SAFELY DECELERATE AND STOP TOWING VEHICLE / MACHINE AND DISABLED VEHICLE BEING TOWED.
- TOWING DISABLED VEHICLE LENGTHENS STOPPING DISTANCES. ALLOW ADEQUATE DISTANCE FOR STOPPING. ANTICIPATE STOPS SO YOU CAN BRAKE GRADUALLY.
- TOW DISABLED VEHICLE AT A REASONABLE SPEED (10 MPH MAXIMUM) TAKING INTO ACCOUNT TRACK CONDITIONS, TRACK GRADE, WEATHER, VISIBILITY AND STOPPING DISTANCE TO ASSURE SAFE OPERATION. RAILROAD RULES GOVERNING SPEED LIMITS AND RIGHT OF WAY SHOULD BE OBSERVED AT ALL TIMES.
- STOPPING DISTANCE IS GREATER ON TRACK THAN ON TYPICAL ROAD SURFACES. APPLY BRAKES GRADUALLY TO AVOID SLIDING TOWING VEHICLE / MACHINE WHEELS.
- MAKE SURE THAT DISABLED VEHICLE'S:
 - FRONT AND REAR GUIDE WHEELS ARE LOWERED AND LOCKED IN RAIL POSITION.
 - ALL GUIDE WHEEL FLANGES ARE ENGAGED ON INSIDE OF RAILS.
 - FRONT TIRES ARE A MINIMUM OF 1-1/2" (38 mm) ABOVE RAIL.
 - VEHICLE STEERING WHEEL LOCK ENGAGED WITH FRONT WHEELS STRAIGHT AHEAD.

FAILURE TO HEED THESE WARNINGS COULD RESULT IN SEVERE BODILY INJURY.

2.13 Towing Disabled Vehicle On Track



2

- TOW BAR MUST BE ATTACHED TO DISABLED VEHICLE'S FRAME. DO NOT MOUNT OR ATTACH TOW BAR TO DISABLED VEHICLE'S GUIDE WHEEL EQUIPMENT.
- TOW BAR MUST HAVE A RATED TOWING CAPACITY EQUAL TO OR GREATER THAN WEIGHT OF DISABLED VEHICLE BEING TOWED.
- USE A RIGID TYPE TOW BAR WITH SAFETY LOCKING COUPLERS. DO NOT USE CHAIN, WIRE ROPE ETC.
- OBSERVE AND FOLLOW ALL RAILROAD SAFETY RULES AND REGULATIONS.
- DO NOT ACCELERATE SUDDENLY. TRACTION IS REDUCED ON RAIL, SPINNING TOWING VEHICLE / MACHINE WHEELS COULD DAMAGE THEM.
- TOW DISABLED VEHICLE TO NEAREST ROAD CROSSING AND REMOVE FROM TRACK.

FAILURE TO HEED THESE PRECAUTIONS COULD RESULT IN BODILY INJURY AND/OR PROPERTY DAMAGE.

2.13 Towing Disabled Vehicle On Track

1. See your vehicle's operators manual for towing information.
2. The towing vehicle / machine must have an adequate brake system to safely decelerate and stop the towing vehicle / machine and the disabled vehicle being towed. The towing vehicle / machine must weigh as much or more than the disabled vehicle towed.
3. Make sure that the disabled vehicle's:
 - a. Front and rear guide wheels are lowered and locked in the rail position.
 - b. All guide wheel flanges are engaged on the inside of the rails.
 - c. Front tires are a minimum of 1-1/2" (38 mm) above the rail.
 - d. Vehicle front wheels are set straight ahead and the steering wheel lock is engaged on the steering column.
4. Make sure the towing vehicle / machine is in good working condition (tires, brakes, lights, etc.) and that current maintenance has been performed on the vehicle / machine.
5. The towing equipment (hitches, tow bars, etc.) on the towing vehicle / machine must have a rating equal to or greater than the weight of the disabled vehicle being towed.
6. The tow bar must be mounted or attached to the disabled vehicle's frame. Do not mount or attach the tow bar to the disabled vehicle's guide wheel equipment. Use a rigid type tow bar with safety locking couplers.
7. Observe and follow all railroad safety rules and regulations.
8. Do not accelerate suddenly. Traction is reduced on rail. Spinning the towing vehicle tires / machine wheels could damage them.
9. Stopping distance is greater on rail than on typical road surfaces. Apply the towing vehicle / machine brakes gradually to avoid sliding the vehicle tires / machine wheels. Towing disabled vehicle lengthens stopping distances. Allow adequate distance for stopping. Anticipate stops so that you can brake gradually.
10. Tow the disabled vehicle on the track at a reasonable speed (10 MPH maximum) taking into account track conditions, track grade, weather, visibility and stopping distance to assure safe operation. Railroad rules and regulations governing speed limits and right of way should be observed at all times.
11. Tow the disabled vehicle to the nearest road crossing and remove the vehicle from the track.

2.14 Towing Disabled Vehicle On Road



2

- TOW DISABLED VEHICLE PER VEHICLE MANUFACTURER'S TOWING SPECIFICATIONS LISTED IN YOUR VEHICLE'S OPERATORS MANUAL.
- VEHICLE USED FOR TOWING MUST HAVE AN ADEQUATE BRAKE SYSTEM TO SAFELY DECELERATE AND STOP TOWING VEHICLE AND DISABLED VEHICLE BEING TOWED.
- TOW DISABLED VEHICLE AT A REASONABLE SPEED TAKING INTO ACCOUNT ROAD CONDITIONS, ROAD GRADE, WEATHER, VISIBILITY AND STOPPING DISTANCE TO ASSURE SAFE OPERATION. POSTED SPEED LIMITS SHOULD BE OBSERVED AT ALL TIMES.
- MAKE SURE DISABLED VEHICLE'S:
 - FRONT AND REAR GUIDE WHEELS ARE RAISED AND LOCKED IN HIGHWAY POSITION.
 - VEHICLE STEERING WHEEL LOCK DISENGAGED.

FAILURE TO HEED THESE WARNINGS COULD RESULT IN SEVERE BODILY INJURY.



- TOWING EQUIPMENT (TOW TRUCK, TOW BARS, ETC.) MUST BE ATTACHED TO DISABLED VEHICLE'S FRAME. DO NOT MOUNT OR ATTACH TOWING EQUIPMENT TO DISABLED VEHICLE'S GUIDE WHEEL EQUIPMENT.
- TOWING EQUIPMENT (TOW TRUCK, TOW BARS, ETC.) MUST HAVE A RATED TOWING CAPACITY EQUAL TO OR GREATER THAN WEIGHT OF DISABLED VEHICLE BEING TOWED.
- OBSERVE AND FOLLOW ALL FEDERAL, STATE AND LOCAL DRIVING RULES AND REGULATIONS.
- STATE LAWS MAY REQUIRE TOWING VEHICLE AND DISABLED VEHICLE TO BE EQUIPPED WITH SPECIAL SAFETY EQUIPMENT (LIGHTS, ETC.).

FAILURE TO HEED THESE PRECAUTIONS COULD RESULT IN BODILY INJURY AND/OR PROPERTY DAMAGE.

2.14 Towing Disabled Vehicle On Road

1. See your vehicle's operators manual for towing information.
2. The towing vehicle must have an adequate brake system to safely decelerate and stop the towing vehicle and the disabled vehicle being towed.
3. Make sure that the disabled vehicle's:
 - a. Front and rear guide wheels are raised and locked in the highway position.
 - b. Vehicle steering wheel lock is disengaged on the steering column.
4. Make sure the towing vehicle is in good working condition (tires, brakes, lights, etc.) and that current maintenance has been performed on the vehicle.
5. The towing equipment (tow truck, tow bars, etc.) on the towing vehicle must have a rating equal to or greater than the weight of the disabled vehicle being towed.
6. The towing equipment (tow truck, tow bars, etc.) must be mounted or attached to the disabled vehicle's frame. Do not mount or attach the towing equipment to the disabled vehicle's guide wheel equipment.
7. Observe and follow all federal, state and local driving rules, regulations and laws.
8. State laws may require the towing vehicle and disabled vehicle being towed to be equipped with special safety equipment (lights, etc.).
9. Tow the disabled vehicle on the road at a reasonable speed taking into account road conditions, road grade, weather, visibility and stopping distance to assure safe operation. Always observe posted speed limits.

SECTION 3 - ADJUSTMENTS
TABLE OF CONTENTS

3.1 Guide Wheel Equipment Alignment Procedure3 - 2

3.1.1 Vehicle Check3 - 2

3.1.2 Placing Vehicle On Track3 - 3

3.1.3 Guide Wheel Back Flange Gauge3 - 4

3.1.4 Guide Wheel Load3 - 5

3.1.4.1 Checking Rear Guide Wheel Load3 - 6

3.1.4.2 Adjusting Rear Guide Wheel Load3 - 8

3.1.5 String Lining Set-Up3 - 11

3.1.6 Guide Wheel Alignment3 - 12

3.1.6.1 Checking / Adjusting Rear Guide Wheel Alignment3 - 12

3.1.7 Vehicle Track Test3 - 14

3.2 Adjustments3 - 16

3.2.1 Rear Guide wheel Unit Lock Adjustment3 - 16

3.2.1.1 Adjusting Rear Guide Wheel Unit Lock - Rail Position3 - 16

3.2.1.2 Adjusting Rear Guide Wheel Unit Lock - Highway Position3 - 16

3.2.2 Brake Shoe Clearance3 - 18

3.2.2.1 Checking Brake Shoe Clearance3 - 18

3.2.2.2 Adjusting Rear Brake Shoe Clearance3 - 18

3.2.3 Rail Sweep Clearance3 - 20

3.2.3.1 Checking Rail Sweep Clearance3 - 20

3.2.3.2 Adjusting Rail Sweep Clearance3 - 20

3.2.4 Hydraulic Pressure Settings and Adjustments3 - 21

3.2.4.1 Rear Guide Wheel Unit Hydraulic Pressure3 - 22

3.2.4.1.1 Checking Rear Guide Wheel Unit Hydraulic Pressure3 - 22

3.2.4.1.2 Adjusting Rear Guide Wheel Unit Hydraulic Pressure3 - 22

3.2.4.2 Rear Guide Wheel Unit Side Shift Hydraulic Pressure3 - 24

3.2.4.2.1 Checking Side Shift Hydraulic Pressure3 - 24

3.2.4.2.2 Adjusting Side Shift Hydraulic Pressure3 - 24

3.2.4.3 Rear Guide Wheel Unit Hydraulic Lock Hydraulic Pressure3 - 25

3.2.4.4 Flow Divider Valve Hydraulic Pressure3 - 26

3.2.4.4.1 Checking Flow Divider Valve Hydraulic Pressure3 - 26

3.2.4.4.2 Adjusting Old Style Flow Divider Valve Hydraulic Pressure3 - 26

3.2.4.4.3 Adjusting New Style Flow Divider Valve Hydraulic Pressure3 - 28

3.1 Guide Wheel Equipment Alignment Procedure



- **ENGINE MUST BE RUNNING TO OPERATE MECHANICAL PTO HYDRAULIC PUMP TO RAISE / LOWER THE GUIDE WHEELS. BEFORE PERFORMING ANY ADJUSTMENTS TO GUIDE WHEEL EQUIPMENT OR VEHICLE, ALWAYS PLACE AUTOMATIC TRANSMISSION IN "PARK" OR MANUAL TRANSMISSION IN "NEUTRAL". APPLY THE PARKING BRAKE.**
- **UNDERSTAND EQUIPMENT OPERATION AND BE AWARE OF ALL PINCH POINTS BEFORE OPERATING OR MAKING ADJUSTMENTS TO THE GUIDE WHEEL EQUIPMENT.**

FAILURE TO HEED THESE WARNINGS COULD RESULT IN SEVERE BODILY INJURY.

3

The Guide Wheel Alignment Check must be completed when any of the misalignment indicators occur. See Operation - Misalignment Indicators.

3.1.1 Vehicle Check

1. The vehicle must be at curb weight with permanent attachments: spare tire, tool box less tools, utility box, crane, aerial lift boom, etc. and without: passengers, baggage, load, etc.
2. Weigh the entire vehicle and record this weight. Weigh both the front and rear axles of the vehicle separately and record these weights. These weights will be used when calculating the guide wheel load.
3. The weight of the vehicle should not exceed the GVWR (Gross Vehicle Weight Rating) and the weight on the front and rear axles should not exceed their respective GAWR (Gross Axle Weight Rating).
4. Permanent attachments to the vehicle such as a tool box, utility box, crane, aerial lift boom, etc. which could cause uneven loading on the guide wheels should be compensated for by adjusting the vehicle suspension (adding leaf springs, coil springs, etc).
5. Tires must be inflated to the tire manufacturer's recommended maximum pressure printed on the sidewalls of the tires or wheel manufacturer's recommended maximum pressure, stamped on the wheel, whichever is lower.
6. Visually inspect the entire vehicle, especially the guide wheel equipment, for loose or missing bolts, and bent or damaged components. Tighten, repair, or replace as necessary.

3.1 Guide Wheel Equipment Alignment Procedure

3.1.1 Vehicle Check

7. Verify that the vehicle the guide wheel equipment is to be mounted to is equipped correctly (springs, tires, wheels, etc.).
8. Check the following measurements on the vehicle.
 - a. Frame must be square. Diagonal measurements of the frame should be equal within 1/8 inch (3.2 mm).
 - b. Wheelbase (as measured on each side) must be equal within 1/16 inch (1.8 mm).
 - c. Vehicle axles must be square with the frame within 1/64 inch per foot (.4 mm per 304 mm). Harsco Rail recommends that this be checked by a reputable alignment shop.
9. Follow the mounting instructions on the application drawings which are supplied with each Guide Wheel Equipment Group.

Note: The applicator of the guide wheel equipment must make sure the application drawings remain with the vehicle for further reference. If the application drawings are not with the vehicle, contact Harsco Rail, Fairmont Minnesota Facility to obtain these drawings.

10. Make sure that the applicator of the guide wheel equipment performed a four point alignment on the vehicle including checking the caster, camber, toe-in on the front wheels and thrust angle of the rear axle. The thrust angle of the rear axle should be set as close to zero as possible. If necessary, adjust to vehicle manufacturer's recommendations.
11. Make sure the headlight aim is checked and adjusted.

3.1.2 Placing Vehicle On Track

1. Place the vehicle on straight, level, tangent track or an alignment rack constructed for guide wheel equipment alignment. If track or an alignment rack is not available, use 4 x 4 inch lumber on a level floor to simulate track. Space the lumber so it measures 56-1/2 inches (1.435 m) between the inside edges.
2. Place the vehicle automatic transmission in "Park" or manual transmission in "Neutral". Apply the parking brake. Lower and lock the guide wheels in the rail position. See Operation - Placing Vehicle On Track.
3. Set the vehicle's front wheels straight ahead. Secure the steering wheel using the steering lock. Stop the engine.

3.1 Guide Wheel Equipment Alignment Procedure

3.1.3 Guide Wheel Back Flange Gauge - See Figure 3-1

1. Measure the back flange gauge on the rear guide wheel unit. Measure from the back of the left wheel flange, directly below the center line of the wheel spindle, to the same point on the right wheel flange. This dimension must be 53-1/4 to 53-3/8 inches (1352 mm to 1356 mm). The back flange gauge is preset at the factory and is non-adjustable.

FIGURE 3-1
GUIDE WHEEL BACK FLANGE GAUGE

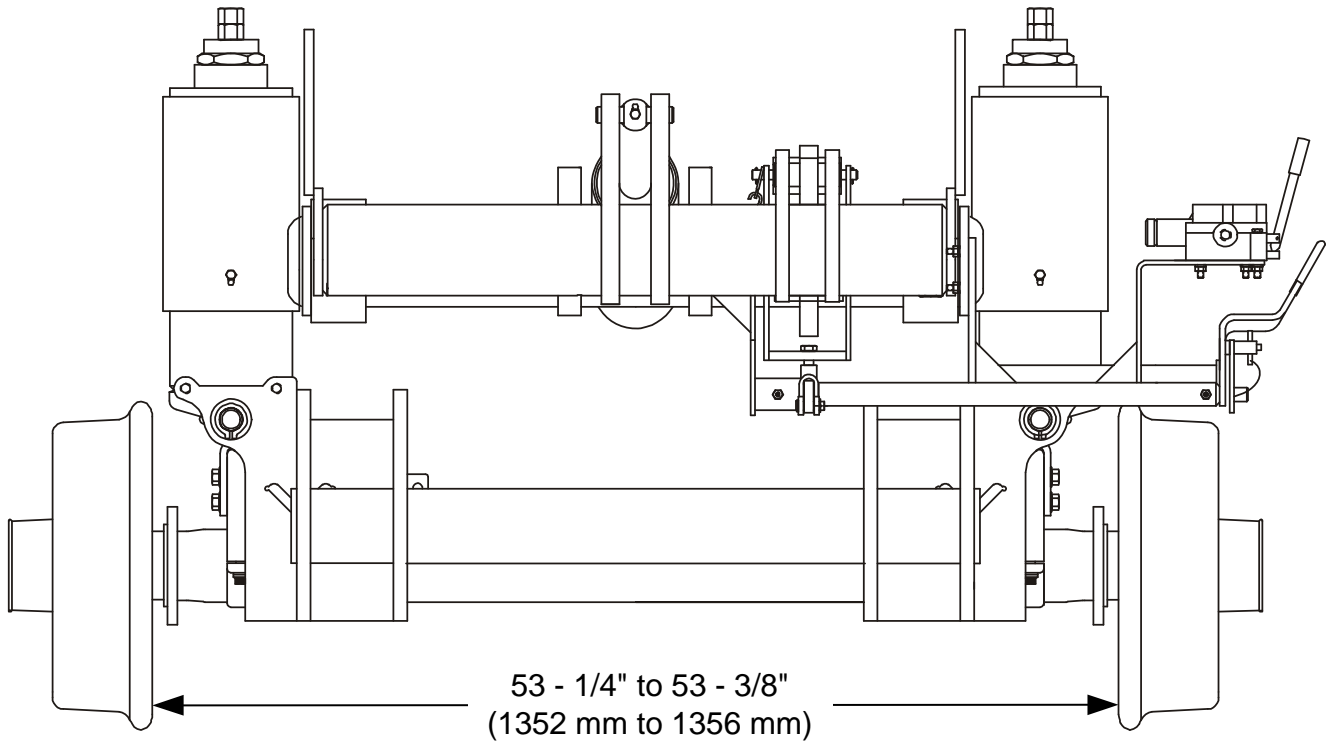

3

3.1 Guide Wheel Equipment Alignment Procedure

3.1.4 Guide Wheel Load



- **IMPROPER LOADING OF GUIDE WHEEL EQUIPMENT CAN CAUSE DERAILMENT OF VEHICLE.**
- **ALWAYS CHECK THE GUIDE WHEEL LOAD BEFORE OPERATING THE VEHICLE ON TRACK.**
- **NEVER OPERATE THE VEHICLE ON TRACK IF LOAD EXCEEDS THE MAXIMUM RATED LOAD OF THE FRONT AND/OR REAR GUIDE WHEEL UNITS. THE MAXIMUM LOAD ON THE REAR GUIDE WHEEL UNIT IS 20,000 LBS (9,072 kg) OR 10,000 LBS (4,536 kg) MAXIMUM PER GUIDE WHEEL.**
- **NEVER OPERATE THE VEHICLE ON TRACK IF CLEARANCE BETWEEN VEHICLE FRONT TIRES AND RAIL IS LESS THAN 1-1/2" (38 mm).**

FAILURE TO HEED THESE WARNINGS COULD RESULT IN DERAILMENT OF VEHICLE AND/OR SEVERE BODILY INJURY.

Whenever the vehicle is loaded or additional load is added to the existing vehicle load on track, check the load on the front and rear guide wheels. The maximum load on the rear guide wheel unit is 20,000 lbs (9,072 kg) or 10,000 lbs (4,536 kg) maximum per guide wheel.

3.1 Guide Wheel Equipment Alignment Procedure

3.1.4 Guide Wheel Load

3.1.4.1 Checking Rear Guide Wheel Load - See Figures 3-2 and 3-3

1. Apply the parking brake. Stop the vehicle's engine.
2. The protrusion of rod (1) on the spring cell is used to determine the load on the rear guide wheels. Measure dimension "X" on both spring cells. See Figure 3-2 to convert dimension "X" to the spring cell load.
3. The minimum rated load capacity of the rear guide wheel unit is 33% of the vehicle's rear axle curb weight, or at least 3,650 lbs (1656 kg) total or 1,825 lbs (828 kg) per guide wheel.

If the measured rear guide wheel load does not meet the minimum rated load capacity of the rear guide wheel unit, total or per guide wheel, the rear guide wheel unit load must be re-adjusted. See 3.1.4.3 Adjusting Rear Guide Wheel Load. Never operate the vehicle on track if the measured load on the rear guide wheel unit does not meet the minimum rated load capacity of 3,650 lbs (1656 kg) total or 1,825 lbs (828 kg) per guide wheel.

4. The maximum rated load capacity of the rear guide wheel unit is 20,000 lbs (9,072 kg) or 10,000 lbs (4,536 kg) maximum per guide wheel.

If the measured rear guide wheel load does not exceed the maximum rated load capacity of the rear guide wheel unit, total or per guide wheel, the load on the rear guide wheel is acceptable.

If the measured rear guide wheel load does exceed the maximum rated load capacity of the rear guide wheel unit, total or per guide wheel, the vehicle load must be redistributed or some of the load removed. Never operate the vehicle on track if the measured load on the rear guide wheel unit exceeds the maximum rated load capacity of 20,000 lbs (9,072 kg) or 10,000 lbs (4,536 kg) maximum per guide wheel.

FIGURE 3-2
MEASURING REAR SPRING CELL

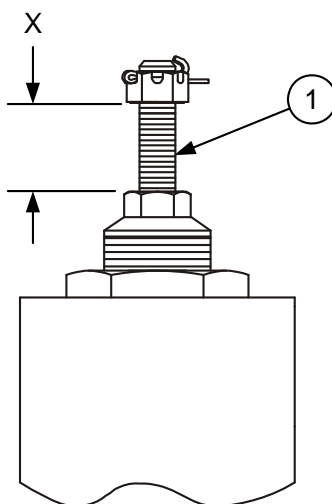

3.1 Guide Wheel Equipment Alignment Procedure

3.1.4 Guide Wheel Load

3.1.4.1 Checking Rear Guide Wheel Load

FIGURE 3-3
REAR GUIDE WHEEL LOAD CHART

DIMENSION X		APPROXIMATE LOAD PER SIDE	
1/2"	12.7 mm	1,660 lbs	744 kg
3/4"	19.1 mm	2,380 lbs	1,080 kg
1"	25.4 mm	3,110 lbs	1,411 kg
1-1/4"	31.8 mm	3,840 lbs	1,742 kg
1-1/2"	38.1 mm	4,580 lbs	2,077 kg
1-3/4"	44.5 mm	5,310 lbs	2,409 kg
2"	50.8 mm	6,050 lbs	2,744 kg
2-1/4"	57.2 mm	6,750 lbs	3,062 kg
2-1/2"	63.5 mm	7,510 lbs	3,407 kg
2-3/4"	69.9 mm	8,250 lbs	3,742 kg
3"	76.2 mm	8,980 lbs	4,073 kg
3-1/4"	82.6 mm	9,710 lbs	4,404 kg
* 3-1/2"	88.9 mm	10,400 lbs	4,717 kg

* REAR GUIDE WHEEL UNIT IS OVERLOADED. REDISTRIBUTE OR REMOVE SOME OF THE LOAD. MAXIMUM LOAD ON REAR GUIDE WHEEL UNIT MUST NOT EXCEED 20,000 LBS (9,072 kg) OR 10,000 LBS (4,536kg) MAXIMUM PER GUIDE WHEEL.

3.1 Guide Wheel Equipment Alignment Procedure

3.1.4 Guide Wheel Load

3.1.4.2 Adjusting Rear Guide Wheel Load - See Figures 3-4 and 3-5

1. The rear guide wheel unit is equipped with two adjustable spring cells. The guide wheel unit should be initially adjusted to carry approximately 33% of the vehicle's rear axle curb weight or a minimum of 3,650 lbs (1,656 kg) with the remainder of the weight being carried by the rear, inner dual tires when the vehicle is on "rail". Whenever the vehicle is loaded or additional load is added to the existing vehicle load on track, check the load on the rear guide wheels. The maximum rated load on the rear guide wheel unit is 20,000 lbs (9,072 kg) or 10,000 lbs (4,536 kg) per guide wheel.
2. The protrusion of the spring cell rods, dimension "X", can be used to determine the load on the guide wheels. Measure dimension "X" on both spring cells. See Figure 3-5 to convert dimension "X" to the load on the guide wheel.
3. To calculate the load setting for each spring cell, use the following formula:
$$\text{Vehicle Rear Axle Weight} \times 17\% (0.17) = \text{Spring Cell Load}$$
4. Convert the calculated spring cell load into dimension "X". If the calculated spring cell load, dimension "X" is less than 1/2 inch (12.7 mm), the spring cell must be set to a minimum of 1/2 inch (12.7 mm).
5. Unlock and raise the rear guide wheels. Let the guide wheels rest on the rails.
6. Dimension (1), the length of the large threaded stud extending from the top of the lock nut (2) to the bottom of adjusting nut (3), is preset at the factory to 3/4 inch (19 mm). This allows approximately equal adjustment up or down. If dimension (1) is not initially set to 3/4 inch (19 mm) on both spring cells, loosen lock nut (2). Turn adjusting nut (3) until dimension (1) is set to 3/4 inch (19 mm) on both spring cells. Re-tighten lock nut (2).
7. Lower and lock the guide wheels in the "rail" position.
8. Measure dimension "X". See Figure 3-5 to convert dimension "X" to the load. The spring cell must be set to the calculated load dimension or the minimum load dimension.
9. To adjust the spring cell load, unlock and raise the rear guide wheels. Let the guide wheels rest on the rails. Loosen lock nut (2). Turn adjusting nut (3) clockwise to increase the load on the guide wheel or counter-clockwise to decrease the load on the guide wheel.
10. Lower and lock the guide wheel unit in the "rail" position. Re-measure dimension "X" and refer to Figure 3-5 to convert dimension "X" to the load on the guide wheel.
11. Repeat Steps 9 and 10 until dimension "X" corresponds to the calculated load or the minimum load on the spring cell. Tighten lock nut (2). Both spring cells must be set to the same dimension (1) within 1/8 inch (3.2 mm).
12. If the spring cell cannot be adjusted to the calculated load or the minimum load, the guide wheel unit must be repositioned in a different set of mounting holes.

3.1 Guide Wheel Equipment Alignment Procedure

3.1.4 Guide Wheel Load

3.1.4.2 Adjusting Rear Guide Wheel Load

FIGURE 3-4
ADJUSTING REAR SPRING CELL

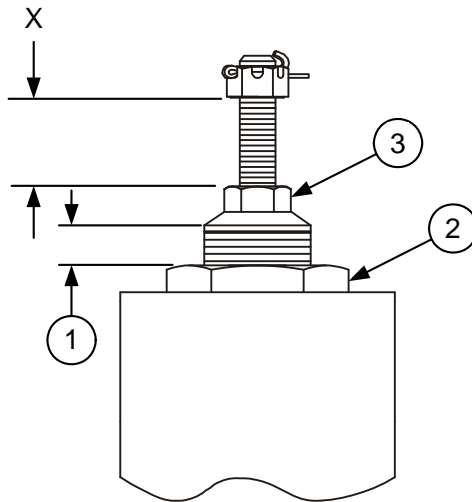

FIGURE 3-5
REAR GUIDE WHEEL LOAD CHART

DIMENSION X		APPROXIMATE LOAD PER SIDE	
1/2"	12.7 mm	1,660 lbs	744 kg
3/4"	19.1 mm	2,380 lbs	1,080 kg
1"	25.4 mm	3,110 lbs	1,411 kg
1-1/4"	31.8 mm	3,840 lbs	1,742 kg
1-1/2"	38.1 mm	4,580 lbs	2,077 kg
1-3/4"	44.5 mm	5,310 lbs	2,409 kg
2"	50.8 mm	6,050 lbs	2,744 kg
2-1/4"	57.2 mm	6,750 lbs	3,062 kg
2-1/2"	63.5 mm	7,510 lbs	3,407 kg
2-3/4"	69.9 mm	8,250 lbs	3,742 kg
3"	76.2 mm	8,980 lbs	4,073 kg
3-1/4"	82.6 mm	9,710 lbs	4,404 kg
* 3-1/2"	88.9 mm	10,400 lbs	4,717 kg

* REAR GUIDE WHEEL UNIT IS OVERLOADED. REDISTRIBUTE OR REMOVE SOME OF THE LOAD. MAXIMUM LOAD ON REAR GUIDE WHEEL UNIT MUST NOT EXCEED 20,000 LBS (9,072 kg) OR 10,000 LBS (4,536kg) MAXIMUM PER GUIDE WHEEL.

3.1 Guide Wheel Equipment Alignment Procedure

FIGURE 3-6
GUIDE WHEEL EQUIPMENT ALIGNMENT

3

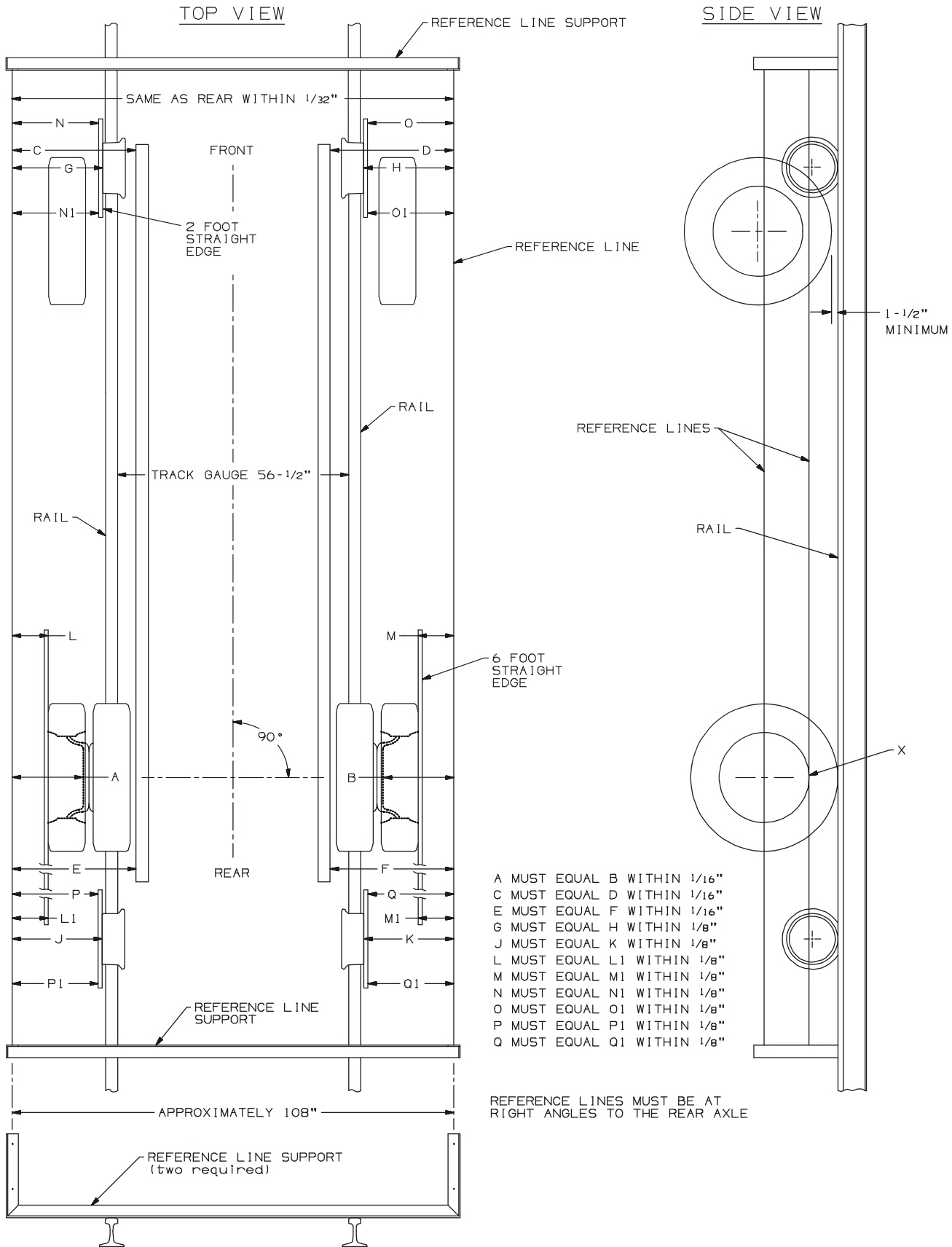

3.1 Guide Wheel Equipment Alignment Procedure

3.1.5 String Lining Set-Up - See Figure 3-6

1. The string lining procedure is only a guide to check and make alignment adjustments to the guide wheel equipment. String lining the vehicle and guide wheel equipment will not guarantee that the guide wheel equipped vehicle will track properly. Harsco Rail recommends that all HY-RAIL® equipped vehicles be track tested. The vehicle should be at its normal operating load for track testing. The vehicle should be track tested when:
 - a. The guide wheel equipment is installed on the vehicle.
 - b. Any adjustments are made to the guide wheel equipment.
 - c. The load on the vehicle is changed.
 - d. Periodically to ensure that the vehicle is tracking properly.
2. Lower and lock both guide wheel units in the "rail" position. See Operation Section - Placing Vehicle On Track. Set the vehicle wheels straight ahead. Secure the vehicle steering wheel using the steering lock.
3. Establish parallel reference lines on each side of the vehicle as shown in Figure 3-6. Parallel reference lines can be established by building two supports or brackets. These can be built out of scrap angle iron or other material. The supports must be high enough so the top reference line is through the center of the rear axle. The supports need to be a few inches longer than the width of the vehicle. Wires or cords stretched between the front and rear supports will be the reference lines. The wires or cords should be spaced approximately 108 inches (2743 mm) apart. The distance between the wires or cords must be equal or within 1/32 inch (.8 mm) at each support.
4. Clamp the supports to the rail in front of and behind the vehicle. The supports should be at right angles to the rail. Stretch the wires or cords between the supports, so the lower reference line is level with the bottom edge of the rear vehicle wheel rim(s) (point X) and the upper reference line is through the center of the rear axle(s). The reference lines must be level.
5. Shift the supports on the rail until dimension A equals (=) B and dimension C equals (=) D or within 1/16 inch (1.6 mm). On disc type wheels, measurements A and B should be taken from the bolt circle area near the center of the wheel to the reference lines. Measurements C and D are taken from the front of the vehicle frame. When shifting the supports, keep them at right angles to the rail so the reference lines stay level and parallel to each other.
6. On spoke wheel / demountable rim type wheels, measurements should be taken using a six (6) foot straight edge, held against the outer edge of the rear, outside tires with the straight edge centered on the tires. Record dimensions L, L1, M and M1 to the reference line. Rotate the rear tires 180 degrees and record a second set of dimensions at L, L1, M and M1. Average the two dimensions taken at L, L1, M and M1.

Example: [L (first dimension) + L (second dimension)] ÷ 2 = L (average dimension)

3.1 Guide Wheel Equipment Alignment Procedure

3.1.5 String Lining Set-Up - See Figure 3-6

7. Shift the supports on the rail until dimension L (average) equals (=) M (average) and dimension L1 (average) equals (=) M1 (average) or within 1/8 inch (3.2 mm). Measurements C and D are taken from the front of the vehicle frame. When shifting the supports, keep them at right angles to the rail so the reference lines stay level and parallel to each other. The reference lines will be parallel only when the rear axle is straight.
8. After the reference lines have been established, measurements can be taken from these lines to the guide wheels to help ensure correct alignment when applying the unit and / or checking the front and rear guide wheel unit alignment to the vehicle.

3

3.1.6 Guide Wheel Alignment

3.1.6.1 Checking / Adjusting Rear Guide Wheel Alignment - See Figures 3-6 and 3-7

1. Lower and lock the front and rear guide wheel units in the "rail" position. Take measurements J and K. Measure from the outer edge of the guide wheel, directly below the center line of the wheel spindle, to the reference lines. Check that dimension J equals (=) dimension K or is within 1/8 inch (3.2 mm). If not adjustment is necessary.
2. Unlock and raise the rear guide wheel unit from the "rail" position. Let the guide wheels rest on the rails. If the unit is equipped with side shift, the self centering v-blocks must remain fully seated in the v-block housing.
3. Loosen cap screws (1) on axle clamps (2). Shift the axle and guide wheels until dimension J equals (=) dimension K or is within 1/8 inch (3.2 mm). If so equipped, make sure the self centering v-blocks are fully seated in the v-block housing. Torque the cap screws. See Appendix A - Bolt Torque Charts.
4. Lower and lock the guide wheel unit in the "rail" position.
5. Repeat Steps 1 through 4 until dimension J equals (=) dimension K or is within 1/8 inch (3.2 mm).
6. The rear guide wheels must track straight. Hold a two foot long straight edge against the outer edge of the rear guide wheel. Take measurements P and P-1 and measurement Q and Q1. Check that dimension P equals (=) dimension P1 and that dimension Q equals (=) dimension Q1 or is within 1/8 inch (3.2 mm). If not, it may be necessary to slightly shift the position of the guide wheel unit where it is mounted to the vehicle frame.

3.1 Guide Wheel Equipment Alignment Procedure

3.1.6 Guide Wheel Alignment

3.1.6.1 Checking / Adjusting Rear Guide Wheel Alignment

FIGURE 3-7
CHECKING / ADJUSTING REAR GUIDE WHEEL ALIGNMENT

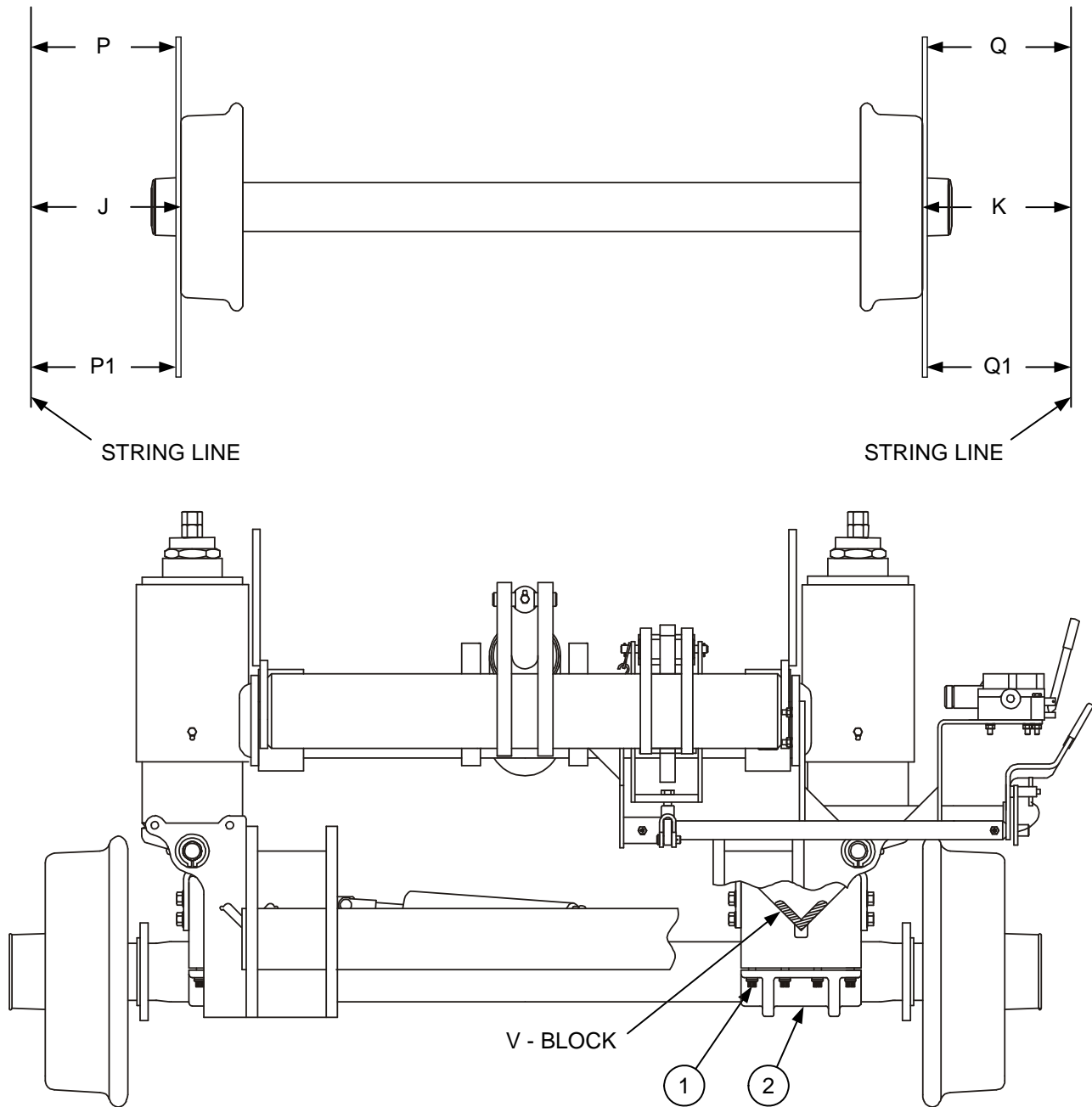

3.1 Guide Wheel Equipment Alignment Procedure

3.1.7 Vehicle Track Test



■ **CHECK AND CORRECT ALIGNMENT PROMPTLY IF MISALIGNMENT IS INDICATED. MISALIGNMENT OF GUIDE WHEEL EQUIPMENT COULD RESULT IN DERAILMENT OF THE VEHICLE AND SEVERE BODILY INJURY.**

3

1. Harsco Rail recommends that all HY-RAIL® equipped vehicles be track tested. The vehicle should be at its normal operating load for track testing. The vehicle should be track tested when:
 - a. The guide wheel equipment is installed on the vehicle.
 - b. Any adjustments are made to the guide wheel equipment.
 - c. The load on the vehicle is changed.
 - d. Periodically to ensure that the vehicle is tracking properly.
2. The vehicle must be placed on straight, level, tangent track. See Operation Section - Placing Vehicle On Track.
3. Apply spray paint to the flanges and treads of all guide wheels.
4. Lower and lock both guide wheel units in the "rail" position.
5. Operate the vehicle a minimum of 1/4 mile at a normal operating speed.
6. The paint should wear evenly around the flanges and treads of all guide wheels. If the paint is worn evenly on all guide wheels, the vehicle and guide wheel equipment is properly aligned.
7. If the paint wore off the right front guide wheel flange and not off the left front guide wheel flange, the guide wheel unit is "flanging right".
 - a. Unlock and lower the front of the vehicle from the "rail" position. Let the guide wheels rest on the rail. Slightly move the right end of the front axle forward or the left end rearward.
 - b. Repaint the flanges and treads on all guide wheels. Lower and lock the guide wheel unit in the "rail" Position. Operate the vehicle for a short distance at a normal operating speed. If the paint is worn evenly on all guide wheels, the vehicle and guide wheel equipment is properly aligned.
 - c. If the paint continues to wear off the right front guide wheel flange and not off the left front guide wheel flange, repeat Steps a. & b. If the guide wheel unit is adjusted to the limit of the mounting hole slots, go to Step 9.

3.1 Guide Wheel Equipment Alignment Procedure

3.1.7 Vehicle Track Test

8. If the paint wore off the left front guide wheel flange and not off the right front guide wheel flange, the guide wheel unit is "flanging left".
 - a. Unlock and lower the front of the vehicle from the "rail" position. Let the guide wheels rest on the rail. Slightly move the left end of the front axle forward or the right end rearward.
 - b. Repaint the flanges and treads on all guide wheels. Lower and lock the guide wheels in the "rail" Position. Operate the vehicle for a short distance at a normal operating speed. If the paint is worn evenly on all guide wheels, the vehicle and guide wheel equipment is properly aligned.
 - c. If the paint continues to wear off the left front guide wheel flange and not off the right front guide wheel flange, repeat Steps a. & b. If the guide wheel unit is adjusted to the limit of the mounting hole slots, go to Step 9.
9. Note which guide wheels, flange and/or tread the paint is worn on.
 - a. Repaint the flanges and treads on all guide wheels.
 - b. Operate the vehicle in reverse a minimum of 1/4 mile at a normal operating speed.
 - c. Note which guide wheels, flange and/or tread the paint is worn on.

If the paint wore off the right front flange when traveling forward and then off the left rear flange when traveling in reverse or off the left front flange when traveling forward and then off the right rear flange when traveling in reverse, the vehicle is probably not aligned properly. Have the frame and rear axle checked for proper alignment. See Vehicle Check.
10. If the vehicle continues to track improperly, repeat the String Lining and Guide Wheel Alignment Procedure.

3.2 Adjustments

3.2.1 Rear Guide Wheel Unit Lock Adjustment - See Figure 3-8

The rear locking mechanism should move freely so it engages when the guide wheels are raised or lowered. Periodically inspect this area for wear. When the vehicle is operated in mud or slush, foreign material may get into the locking mechanism, preventing the lock from operating properly. Remove any foreign material, being careful not to damage the lock mechanism.

1. When the rear guide wheel unit is in the "rail" position, the spring cells should be vertical (perpendicular) to the rail for the spring suspension to work properly.
2. Place the vehicle on straight, level track. Place the vehicle's automatic transmission in "Park" or manual transmission in "Neutral". Apply the parking brake. Lower and lock the front and rear guide wheel units in the "rail" position.
3. Place a bubble level on the front or rear side of either spring cell. The spring cells should be vertical (perpendicular) to the rail. If not, adjustment is necessary.

3.2.1.1 Adjusting Rear Guide Wheel Unit Lock - Rail Position

1. Unlock and raise the rear guide wheel unit, let the guide wheels rest on the rail.
2. Turn set screws (1) counter-clockwise to move the bottom of the spring cell rearward or clockwise to move the bottom of the spring cell forward. Adjust both set screws equally.
3. Lower the guide wheel unit to the "rail" position. Re-check the guide wheel unit spring cells to see if they are vertical (perpendicular) to the rail. If not, repeat Steps 1 and 2 until the spring cells are vertical (perpendicular) to the rail.
4. After adjusting the spring cells to the vertical position, check the operation of lock pawl (2). Check the clearance between locking pawl (2) and lock arm (3). There should be approximately 1/16 - 1/8 inch (1.6 - 3.2 mm) clearance.

If the clearance is greater than 1/8 inch (3.2 mm), a shim will have to be welded onto locking pawl (2) at point (4).

If the clearance is less than 1/16 inch (1.6 mm) or if locking pawl (2) will not fully engage into lock arm (3), material will have to be removed from the locking pawl at point (4). Be sure to maintain the locking pawl profile when grinding material from the locking pawl.

3.2.1.2 Adjusting Rear Guide Wheel Unit Lock - Highway Position

1. When the rear guide wheel unit is raised, locking pawl (2) must securely hold the rail unit in the "highway" position. Set screws (5) must be adjusted to help keep the pilot unit from bouncing when traveling on the highway.

3.2 Adjustments

3.2.1 Rear Guide Wheel Unit Lock Adjustment - See Figure 3-8

3.2.1.2 Adjusting Rear Guide Wheel Unit Lock - Highway Position

2. With the guide wheel unit in the "highway" position, check the clearance between set screws (5) and arm (6). If there is excessive clearance, turn set screws (5) clockwise. Adjust both set screws equally.
3. After adjustment, check the operation of the lock. Locking pawl (2) must fully engage locking arm (3). If not, re-adjust set screws (5).

FIGURE 3-8
REAR GUIDE WHEEL UNIT LOCK ADJUSTMENT

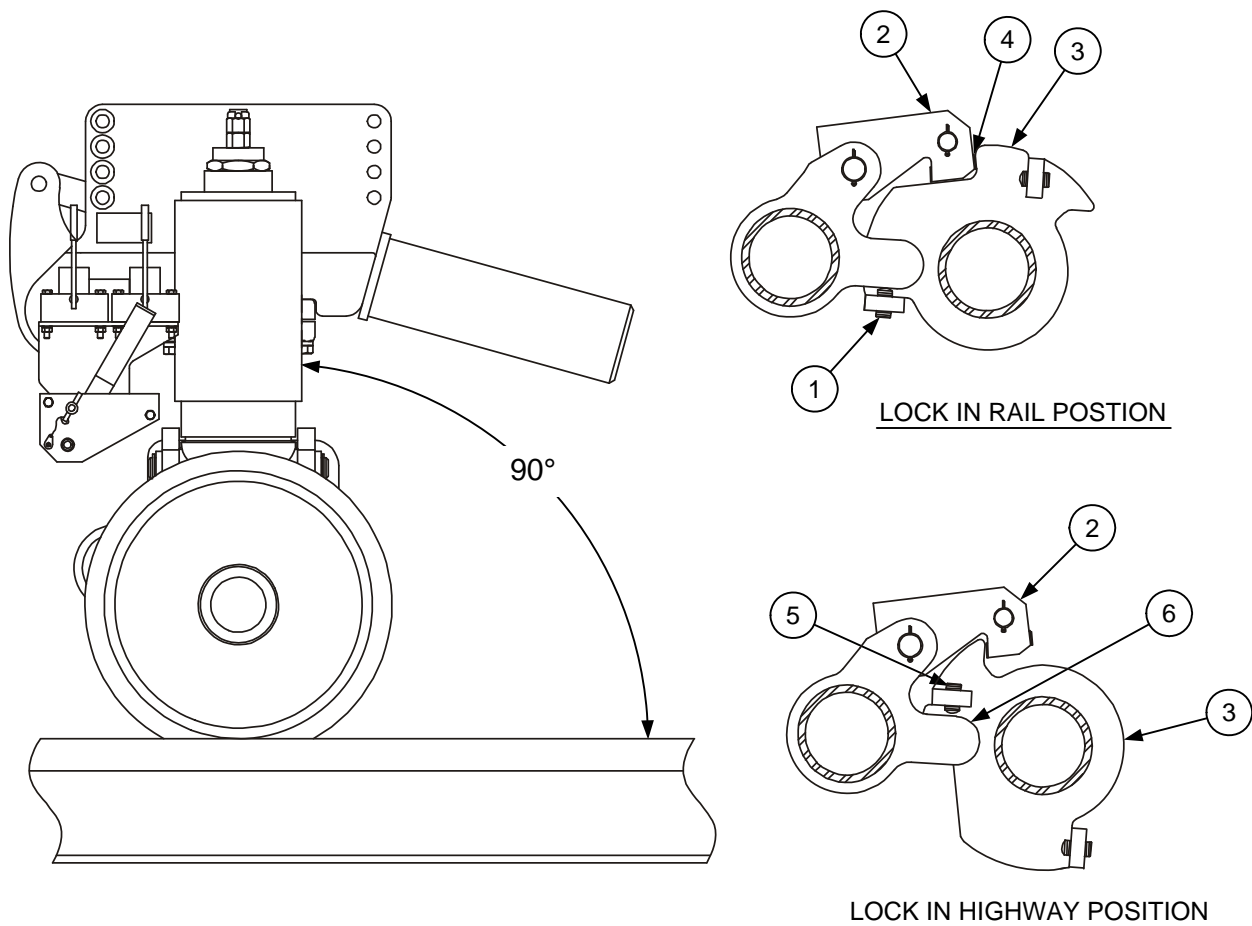

3.2 Adjustments

3.2.2 Brake Shoe Clearance - See Figure 3-9

3.2.2.1 Checking Brake Shoe Clearance

1. The rear guide wheel unit may be equipped with guide wheel brakes.
2. Apply the parking brake. Be sure the vehicle air brake system is at operating pressure to fully release the guide wheel brakes. If so equipped, move the rail wheel brake control valve to the ON position.
3. Measure the clearance between the brake shoe and the guide wheel tread. The clearance must not exceed 1/8 inch (3.2 mm), or adjustment is required. See Adjustment.
4. Repeat Step 3 to check the brake shoe clearance on the other guide wheels.

3.2.2.2 Adjusting Rear Brake Shoe Clearance

1. Remove the cotter pin from pin (1). Remove pin (1) from yoke (2) on the brake actuator (3). Loosen jam nut on yoke (2). Turn yoke (2) counter-clockwise to adjust the brake shoe closer to the guide wheel tread or clockwise to adjust the brake shoe away from the guide wheel tread.
2. Adjust so the brake shoe is 1/32 - 1/16 inch (.8 - 1.6 mm) away from the guide wheel tread. Install pin (1) through yoke (2) and brake arm (4) and secure using cotter pin. Tighten jam nut on yoke (2) securely. Recheck the brake shoe clearance and if necessary, adjust.
3. Repeat Steps 1 and 2 to adjust the brake shoe clearance on the other rear guide wheel.

3.2 Adjustments

3.2.2 Brake Shoe Clearance

FIGURE 3-9
CHECKING / ADJUSTING REAR BRAKE SHOE CLEARANCE

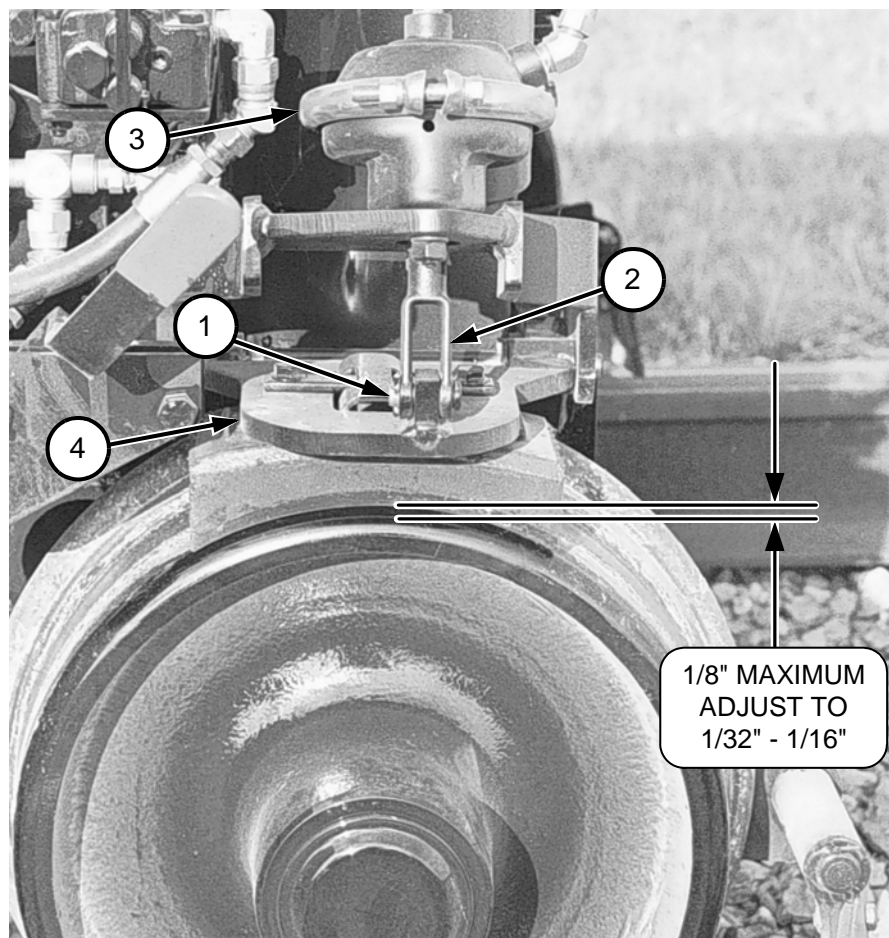

3.2 Adjustments

3.2.3 Rail Sweep Clearance - See Figure 3-10

3.2.3.1 Checking Rail Sweep Clearance

The rear guide wheel unit may be equipped with rail sweeps.

1. Place the vehicle on straight, level track. Place the vehicle automatic transmission in "Park" or manual transmission in "Neutral". Apply the vehicle parking / emergency brake. Lower and lock the front and rear guide wheels in the "rail" position.
2. Measure the rail sweep to rail clearance. The rubber rail sweeps should clear the top of the rail by 1/4 inch (6.4 mm). If not, see Adjustment.

3

3.2.3.2 Adjusting Rail Sweep Clearance

1. Loosen fasteners (1). Slide the rubber sweep (2) down until it clears the top of the rail by 1/4 inch (6.4 mm). Re-tighten fasteners (1).
2. Repeat this procedure to adjust the rail sweep clearance on the other guide wheels.
3. When the rubber sweep is worn so it cannot be adjusted, replace the rubber sweep (2).

FIGURE 3-10
RAIL SWEEP CLEARANCE

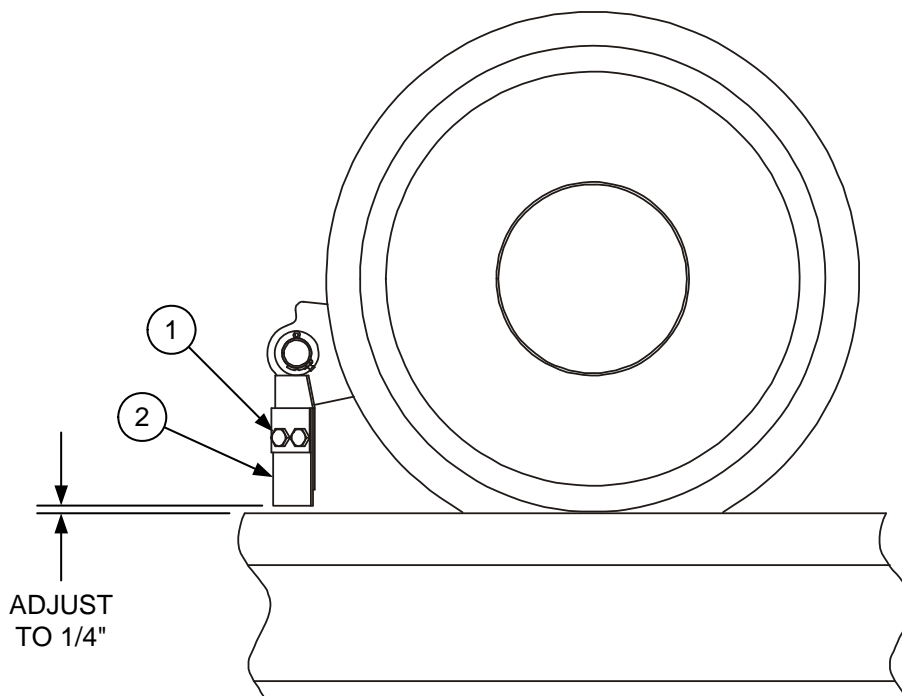

3.2 Adjustments

3.2.4 Hydraulic Pressure Settings and Adjustments



- **WHEN PERFORMING HYDRAULIC PRESSURE ADJUSTMENTS AND / OR REMOVING HYDRAULIC LINES, FITTINGS OR COMPONENTS, THE FOLLOWING PROCEDURE MUST BE ADHERED TO:**
 - **PLACE AUTOMATIC TRANSMISSION IN "PARK" OR MANUAL TRANSMISSION IN "NEUTRAL". APPLY VEHICLE PARKING BRAKE.**
 - **STOP HYDRAULIC POWER SOURCE.**
 - **ALWAYS WEAR APPROPRIATE PERSONAL SAFETY EQUIPMENT.**
 - **ALL SAFETY LOCKS MUST BE APPLIED OR COMPONENT(S) BLOCKED TO RESTRICT MOVEMENT.**
 - **DEPRESSURIZE HYDRAULIC SYSTEM. ESCAPING FLUID CAN WHIP HOSES AND EXPEL FITTINGS OR COMPONENTS AT HIGH VELOCITY.**
 - **NEVER REMOVE LINES, FITTINGS OR COMPONENTS WHEN HYDRAULIC FLUID IS HOT. HOT HYDRAULIC FLUID CAN CAUSE SERIOUS BODILY BURNS.**
 - **REMOVE LINES, FITTINGS OR COMPONENTS SLOWLY TO RELEASE ANY TRAPPED PRESSURE.**
 - **IF INJURY RESULTS FROM ESCAPING FLUID, SEE A DOCTOR AT ONCE; SERIOUS REACTION OR INFECTION MAY RESULT IF PROPER MEDICAL ATTENTION IS NOT OBTAINED IMMEDIATELY.**

FAILURE TO HEED THESE WARNINGS COULD RESULT IN SEVERE BODILY INJURY.

1. Hydraulic pressures are set when the applicator applied the guide wheel units to the vehicle. Pressure settings should not be changed unless an operation malfunction indicates an incorrect pressure setting. Do not exceed recommended pressure setting ranges. Excessive pressure could cause system damage.
2. When a new hydraulic control valve is installed, the hydraulic pressure for the circuit should always be checked and if necessary, adjusted as the new valve from the factory may not be set to the correct pressure.

3.2 Adjustments

3.2.4 Hydraulic Pressure Settings and Adjustments

3.2.4.1 Rear Guide Wheel Unit Hydraulic Pressure

3.2.4.1.1 Checking Rear Guide Wheel Unit Hydraulic Pressure - See Figure 3-11

1. Attach a Harsco Rail pressure gauge No. 099137K to test port (1) on the rear guide wheel unit control valve. If there is not a test port, it will be necessary to tee one in at the pressure (IN) port on the control valve.
2. Start the vehicle engine. Place the vehicle automatic transmission in "Park" or manual transmission in "Neutral". Apply the parking brake. Engage the mechanical PTO hydraulic pump or start the auxiliary hydraulic power source. If the vehicle is equipped with an auxiliary control valve, place the valve in the proper position to direct hydraulic oil flow to the guide wheel equipment.
3. Do not release the guide wheel unit locking mechanism. Push control valve handle (2) towards the vehicle to bottom out the hydraulic cylinder against the locking mechanism. Hold the control valve handle in this position while reading the hydraulic pressure on the gauge. Release the control valve handle.

If the hydraulic pressure indicated is 1800 PSI (124 bar) \pm 50 PSI (3.4 bar), the guide wheel unit hydraulic pressure is set correctly. Disengage the mechanical PTO hydraulic pump or stop the auxiliary hydraulic power source. Remove the pressure gauge from test port (1) or remove the pressure gauge that was installed at the pressure port.

If the pressure indicated is not 1800 PSI (124 bar) \pm 50 PSI (3.4 bar), go to Adjustment.

3.2.4.1.2 Adjusting Rear Guide Wheel Unit Hydraulic Pressure - See Figure 3-11

1. Remove the relief valve cap (3) from the control valve to access the adjusting screw.
2. Do not release the guide wheel unit locking mechanism. Push and hold control valve handle (2) towards the vehicle to bottom out the hydraulic cylinder against the locking mechanism.
3. While observing the pressure gauge, turn the adjusting screw clockwise to increase the pressure or counter-clockwise to decrease the pressure. Stop when the pressure gauge remains steady at 1800 PSI (124 bar) \pm 50 PSI (3.4 bar). Release the control valve handle.
4. Disengage the mechanical PTO hydraulic pump or stop the auxiliary hydraulic power source. Remove the pressure gauge from test port (1) or remove the pressure gauge that was installed at the pressure port. Install the relief valve cap (3).
5. Vehicles equipped with a Harsco Rail Hydraulic Power Pack: If a constant pressure of 1800 PSI (124 bar) \pm 50 PSI (3.4 bar) can not be obtained at the control valve, the flow divider valve may have to be adjusted. See Flow Divider Valve Hydraulic Pressure.

3.2 Adjustments

3.2.4 Hydraulic Pressure Settings and Adjustments

3.2.4.1 Rear Guide Wheel Unit Hydraulic Pressure

FIGURE 3-11
REAR GUIDE WHEEL UNIT CONTROL VALVES

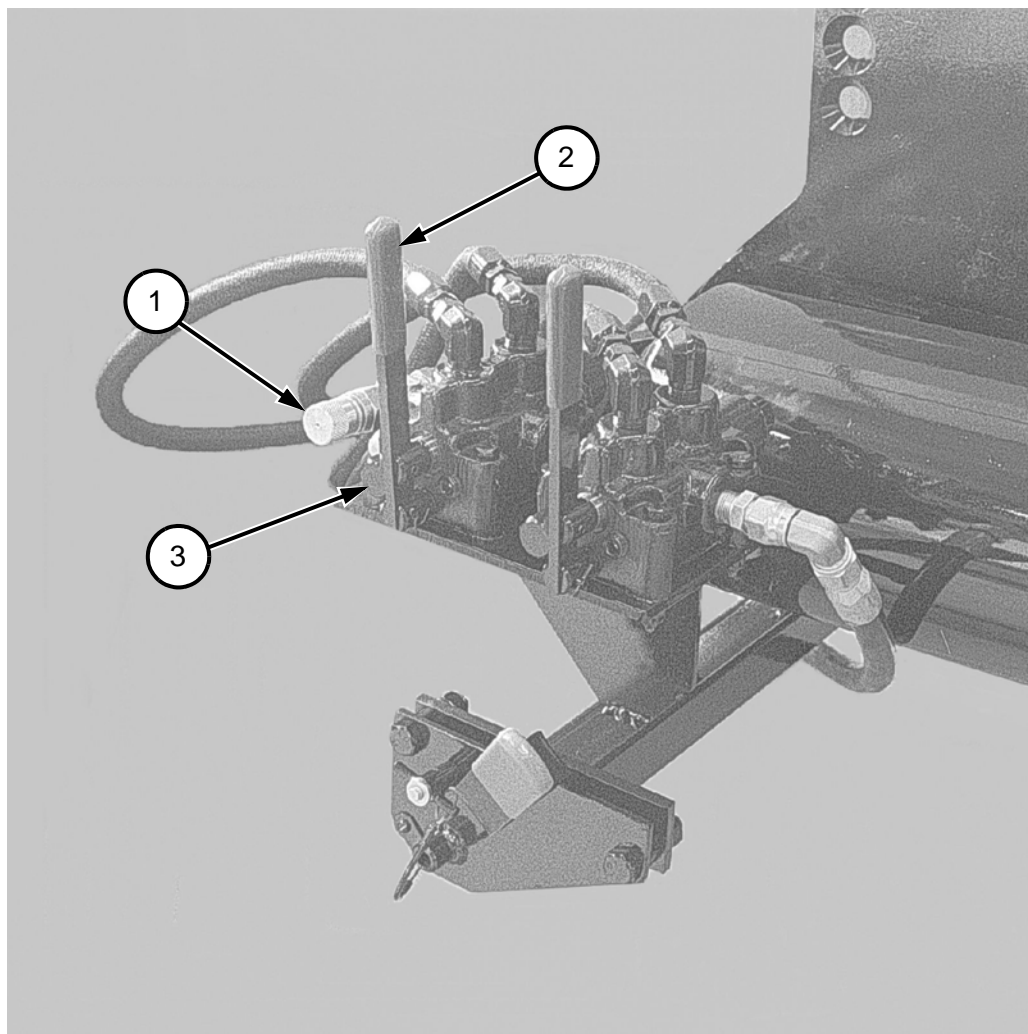

3.2 Adjustments

3.2.4 Hydraulic Pressure Settings and Adjustments

3.2.4.2 Rear Guide Wheel Unit Side Shift Hydraulic Pressure

3.2.4.2.1 Checking Side Shift Hydraulic Pressure - See Figure 3-12

1. Some HR4000A2 rear guide wheel units are equipped with rear axle side shift. Tee a pressure gauge into one of the hydraulic hoses (1) on the control valve that are connected to the side shift cylinder.
2. Start the vehicle engine. Place the vehicle automatic transmission in "Park" or manual transmission in "Neutral". Apply the parking brake. Engage the mechanical PTO hydraulic pump or start the auxiliary hydraulic power source. If the vehicle is equipped with an auxiliary control valve, place the valve in the proper position to direct hydraulic oil flow to the guide wheel equipment.
3. Push or pull control valve handle (2), depending on which hose the pressure gauge is connected to, to bottom out the side shift hydraulic cylinder. Hold the control valve handle in this position while reading the hydraulic pressure on the gauge. Release the control valve handle.

If the hydraulic pressure indicated is 500 PSI (34.5 bar) \pm 25 PSI (1.7 bar), the guide wheel unit hydraulic pressure is set correctly. Disengage the mechanical PTO hydraulic pump or stop the auxiliary hydraulic power source. Remove the pressure gauge from test port (1) or remove the pressure gauge that was installed at the pressure port.

If the pressure indicated is not 500 PSI (34.5 bar) \pm 25 PSI (1.7 bar), go to Adjustment.

3.2.4.2.2 Adjusting Side Shift Hydraulic Pressure - See Figure 3-12

1. Remove the relief valve cap (3) from the control valve to access the adjusting screw.
2. Push or pull and hold control valve handle (2), depending on which hose the pressure gauge is connected to, to bottom out the side shift hydraulic cylinder.
3. While observing the pressure gauge, turn the adjusting screw clockwise to increase the pressure or counter-clockwise to decrease the pressure. Stop when the pressure gauge remains steady at 500 PSI (34.5 bar) \pm 25 PSI (1.7 bar). Release the control valve handle.
4. Disengage the mechanical PTO hydraulic pump or stop the auxiliary hydraulic power source. Remove the pressure gauge that was installed at the cylinder hose port. Install the relief valve cap (3).

3.2 Adjustments

3.2.4 Hydraulic Pressure Settings and Adjustments

3.2.4.2 Rear Guide Wheel Unit Side Shift Hydraulic Pressure

FIGURE 3-12
REAR GUIDE WHEEL UNIT CONTROL VALVES

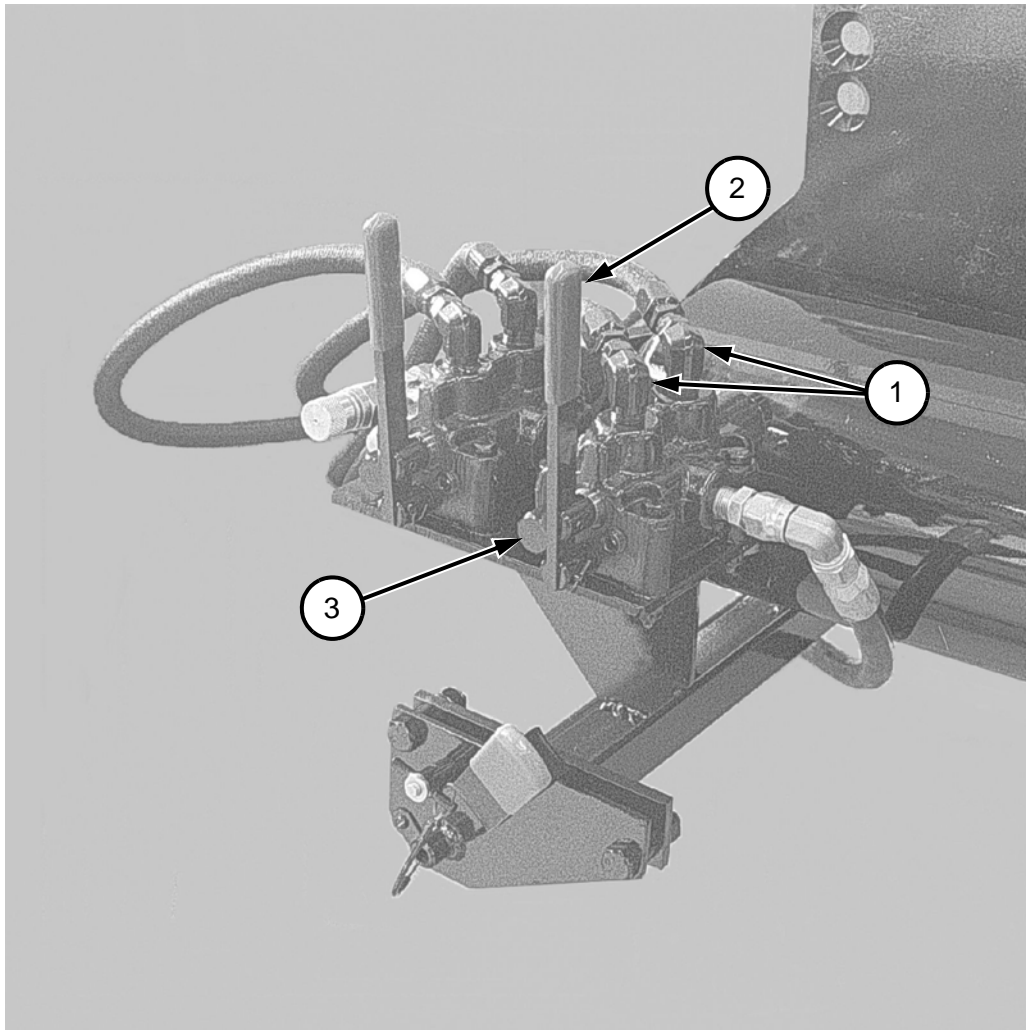

3.2.4.3 Rear Guide Wheel Unit Hydraulic Lock Hydraulic Pressure

1. If the rear guide wheel unit is equipped with a hydraulically actuated lock, there will be a third valve located next to the two valves shown in Figure 3-19. The recommended hydraulic pressure relief setting is 300 PSI (20.7 bar) \pm 25 PSI (1.7 bar).
2. Check and adjust the hydraulic pressure relief setting referring to the procedure used for checking and adjusting the side shift hydraulic pressure.

3.2 Adjustments

3.2.4 Hydraulic Pressure Settings and Adjustments

3.2.4.4 Flow Divider Valve Hydraulic Pressure

3.2.4.4.1 Checking Flow Divider Valve Hydraulic Pressure

1. Attach a Harsco Rail pressure gauge No. 099137K to the test port on the front guide wheel unit control valve. If there is not a test port, it will be necessary to tee one in at the pressure (IN) port on the control valve.
2. Start the vehicle engine. Place the vehicle automatic transmission in "Park" or manual transmission in "Neutral". Apply the parking brake. Engage the mechanical PTO hydraulic pump or start the auxiliary hydraulic power source. If the vehicle is equipped with an auxiliary control valve, place the valve in the proper position to direct hydraulic oil flow to the guide wheel equipment.
3. Do not release the guide wheel unit locking mechanism. Push and hold the control valve handle towards the vehicle to bottom out the hydraulic cylinder against the locking mechanism.
4. While holding the control valve handle, turn the adjusting screw clockwise to increase the pressure. Stop when the pressure gauge remains steady. The pressure indicated is the relief setting of the flow divider valve.

If the hydraulic pressure indicated is 2500 PSI (172 bar) \pm 50 PSI (3.4 bar), the flow divider valve hydraulic relief pressure is set correctly.

If the hydraulic pressure indicated is not 2500 PSI (172 bar) \pm 50 PSI (3.4 bar), the flow divider valve hydraulic relief pressure will have to be adjusted. Go to Adjusting Flow Divider Valve Hydraulic Pressure.

5. While holding the control valve handle, turn the adjusting screw counter-clockwise to decrease the pressure. Stop when the pressure gauge remains steady at 2200 PSI (152 bar) \pm 50 PSI (3.4 bar). Release the control valve handle.
6. Disengage the mechanical PTO hydraulic pump or stop the auxiliary hydraulic power source. Remove the pressure gauge from the test port (1). Install the relief valve cap (3).

3.2.4.4.2 Adjusting Old Style Flow Divider Valve Hydraulic Pressure

See Figures 3-13 and 3-14

1. Disengage the mechanical PTO hydraulic pump or stop the auxiliary hydraulic power source. Stop the vehicle engine. Depressurize the vehicle hydraulic system.
2. Disassemble the flow divider valve by removing the relief cap (1), o-ring (2), relief spring (3), shims (4) and spring guide (5). The relief ball (6), relief seat (7), back-up washer (8) and o-ring (9) in the flow divider valve do not have to be removed.

3.2 Adjustments

3.2.4 Hydraulic Pressure Settings and Adjustments

3.2.4.4 Flow Divider Valve Hydraulic Pressure

3.2.4.4.2 Adjusting Old Style Flow Divider Valve Hydraulic Pressure

See Figures 3-13 and 3-14

3. Add or remove different thicknesses of shims (4) between the relief spring (3) and relief guide (5) to obtain the correct pressure setting of 2500 PSI (172 bar) \pm 50 PSI (3.4 bar). See Figure 3-20 for approximate pressure change in relationship to shim thickness. Re-assemble the flow divider valve in reverse order.

FIGURE 3-13
SHIM / PRESSURE CHART

SHIM THICKNESS	APPROXIMATE PRESSURE CHANGE
.010 in	75 PSI
.021 in	175 PSI
.042 in	425 PSI

4. Repeat this procedure until the correct flow divider valve hydraulic pressure setting is obtained.
5. If the flow divider valve hydraulic pressure can not be adjusted to 2500 PSI (172.4 bar) \pm 50 PSI (3.4 bar), the problem may be with the hydraulic pump.

FIGURE 3-14
OLD STYLE FLOW DIVIDER VALVE

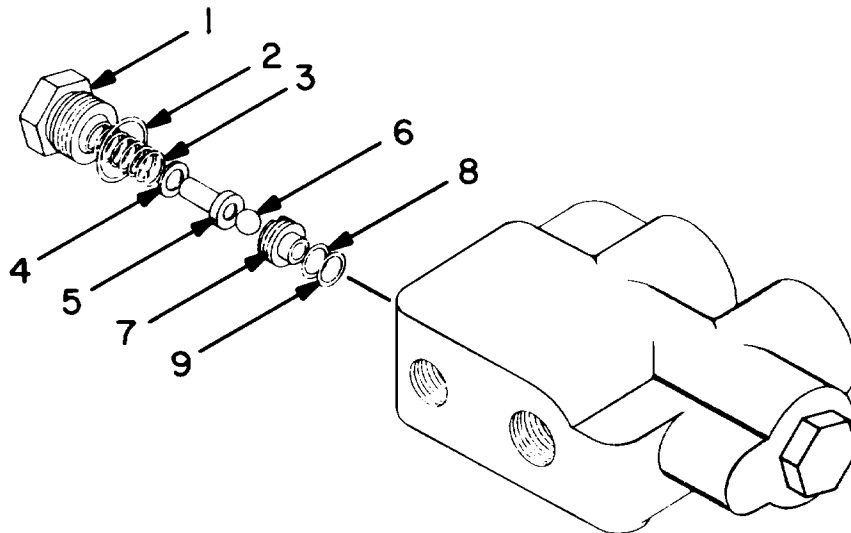

3.2 Adjustments

3.2.4 Hydraulic Pressure Settings and Adjustments

3.2.4.4 Flow Divider Valve Hydraulic Pressure

3.2.4.4.3 Adjusting New Style Flow Divider Valve Hydraulic Pressure

See Figure 3-15

1. The pressure relief screw is located inside the tank port (1) on the flow divider valve.
2. Using an allen wrench turn the relief adjusting screw clockwise to increase the pressure setting or counter-clockwise to decrease the pressure setting. Stop when the pressure gauge remains steady at 2500 PSI (172 bar) \pm 50 PSI (3.4 bar).

3

FIGURE 3-15
NEW STYLE FLOW DIVIDER VALVE



**SECTION 4 - MAINTENANCE
TABLE OF CONTENTS**

4.1 Waste Disposal4 - 2

4.2 Maintenance Schedule4 - 2

4.2.1 Daily4 - 2

4.2.2 Weekly4 - 3

4.2.3 At 2,000 Track Miles (3200 km)4 - 3

4.2.4 At 10,000 Track Miles (16000 km)4 - 3

4.3 Guide Wheel Equipment Lubrication.4 - 4

4.3.1 Rear Guide Wheel Unit Lubrication4 - 4

4.3.2 Re-Packing Guide Wheel Bearings4 - 6

4.4 Guide Wheels4 - 8

4.4.1 Allowable Wear.4 - 8

4.5 Vehicle Wheels4 - 9

4.5.2 Tire Replacement4 - 9

4.6 Bolt Torque Requirements.4 - 9

4.7 Hoses And Fittings4 - 10

4.7.1 Inspection, Maintenance, Replacement And Installation4 - 10

4.7.2 Hose Band4 - 10

4.1 Waste Disposal

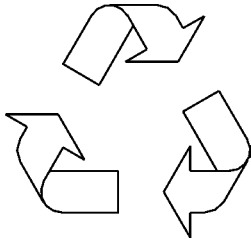

Dispose of waste properly. Improper disposal of waste can threaten the environment. The operation and maintenance of Harsco Rail equipment may involve the use of such items as hydraulic oil, engine oil, fuel, coolant, brake fluid, filters, batteries, etc.

Use leak proof containers when draining fluids. Do not pour waste onto the ground, down a drain, or into any water source. Inquire on the proper way to recycle or dispose of waste according to applicable Federal, State and/or local regulations.

4.2 Maintenance Schedule



- **RE-TORQUE VEHICLE WHEEL LUG NUTS AND GUIDE WHEEL BOLTS AFTER THE FIRST 50 MILES OF OPERATION. THEREAFTER TORQUE WHEEL LUG NUTS ACCORDING TO VEHICLE MANUFACTURER'S WHEEL TORQUE SPECIFICATIONS. FAILURE TO COMPLY COULD RESULT IN SEVERE BODILY INJURY.**

4

4.2.1 Daily

1. Inspect the front and rear guide wheel units for damaged, worn or missing parts.
2. Check the locks and lock pins for ease of operation.
3. The lock pins should never be able to be pulled out unless the button on the "T" end of the pin is pushed in. The button in the lock pin must push in easily and also pop out when released. The locking balls in the end of the pin must work freely so the pin cannot be removed until the button in the lock pin is depressed. If the lock pin does not operate properly, replace the lock pin.
4. Check the hydraulic reservoir to ensure that the oil level is full. If low, fill to the proper level with the correct fluid.
5. When the vehicle is operated on the track, listen for unusual noises. Unusual noises may indicate incorrectly lowered guide wheels, damaged or missing parts, or insufficient lubrication. Pay attention to the quality of the ride. Check the guide wheel equipment alignment if the vehicle crowds one side of the track instead of floating from side to side. See Adjustments - Guide Wheel Equipment Alignment Procedure.

4.2 Maintenance Schedule

4.2.2 Weekly

1. Check the guide wheel equipment alignment. See Adjustment Section, Guide Wheel Equipment Alignment Procedure - Vehicle Track Test.
2. Inspect the guide wheel tread and flanges for wear or damage. See Maintenance - Guide Wheel Allowable Wear.
3. Spin each guide wheel by hand, checking for ease of rotation. If the guide wheel does not rotate easily, the guide wheel bearings may be lacking lubrication or may be damaged. Inspect, re-pack or replace the bearings if necessary.
4. Inspect the vehicle wheels, studs, lug nuts and tires for wear, damage, cuts etc.
5. Check the vehicle tires for correct inflation pressure. Operate at the tire manufacturer's recommended maximum pressure printed on the sidewalls of the tires, or the wheel manufacturer's recommended maximum pressure stamped on the wheel, whichever is lower.
6. Check all bolts for tightness. See Appendix A for bolt torque specification tables and grade identification markings used by manufacturers.

4.2.3 Every 2,000 Track Miles (3200 km)

Lubricate the guide wheel equipment every 2000 track miles (maximum) or each time the vehicle is serviced. See Guide Wheel Equipment Lubrication.

4.2.4 At 10,000 Track Miles (16000 km)

Re-pack and adjust the guide wheel bearings. See Re-packing Guide Wheel Bearings.

4.3 Guide Wheel Equipment Lubrication

Lubricate the guide wheel equipment every 2000 track miles (maximum) or each time the vehicle is serviced.

4.3.1 Rear Guide Wheel Unit Lubrication - See Figure 4-1

1. Apply the vehicle parking brake. Stop the vehicle engine. Turn the vehicle's ignition switch off.
2. Lubricate grease fittings (1) using Mobil Special Moly, or equivalent.
3. Re-pack the guide wheel bearings every 10,000 track miles (maximum) or at least once yearly (minimum), whichever occurs first. See Re-packing Guide Wheel Bearings.

4.3 Guide Wheel Equipment Lubrication

4.3.1 Rear Guide Wheel Unit Lubrication

FIGURE 4-1
REAR GUIDE WHEEL UNIT LUBRICATION

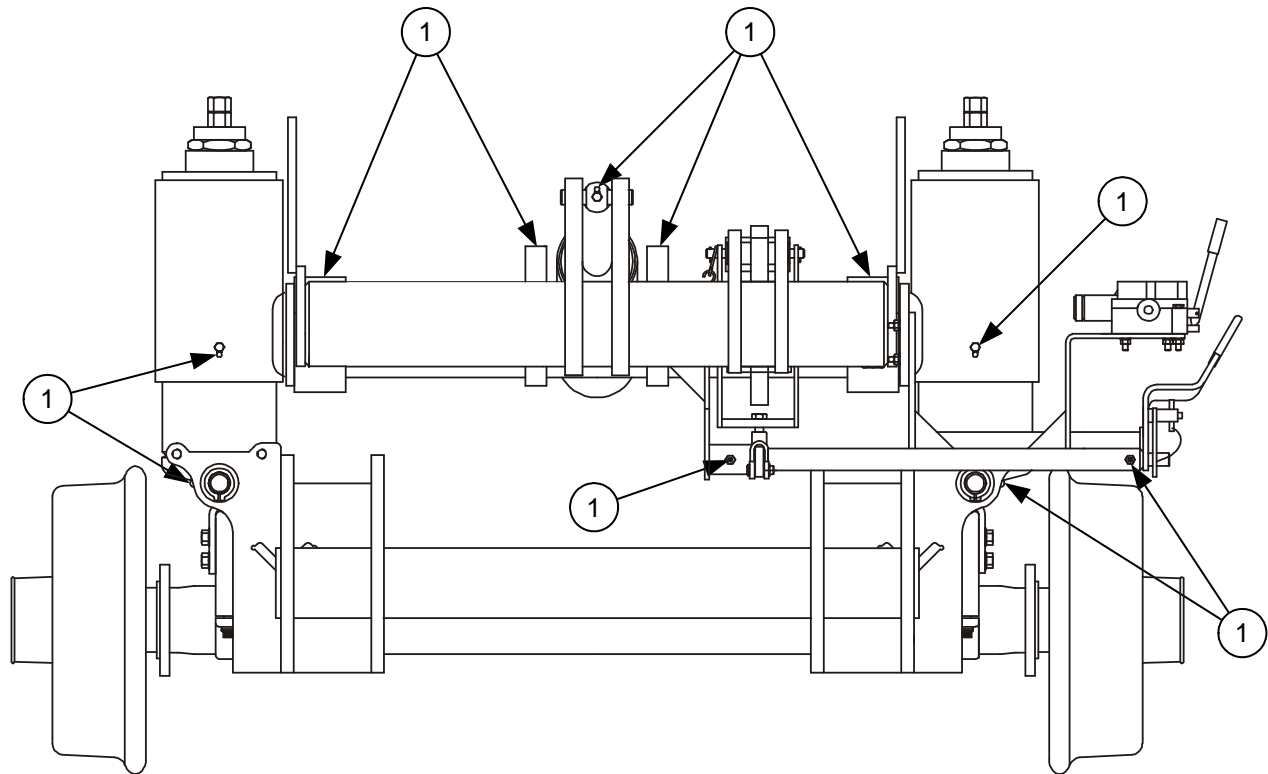

4.3 Guide Wheel Equipment Lubrication

4.3.2 Re-Packing Guide Wheel Bearings - See Figure 4-2

Re-pack the guide wheel bearings every 10,000 track miles (maximum) or at least once every two years (minimum), whichever occurs first.

1. Apply the parking brake. Raise and lock the front and rear guide wheel units in the "highway" position. Stop the vehicle engine. Shut off the vehicle ignition switch.
2. Remove the hub cap (1). Remove the 3/16 x 2-1/2 inch cotter pin (2), 1-1/2 inch castle nut (3) and spindle washer (4).
3. Pull the guide wheel (5) from the spindle (6). Remove the outer bearing cone (7) from the guide wheel (5). Remove the grease seal (11) and inner bearing cone (9) from the guide wheel (5).
4. Clean all components of old grease and dirt.
5. Inspect the spindle, bearing cones and cups (7 & 8, 9 & 10) for nicks, gouges and wear. If any of these are evident, replace the component.
6. Measure the guide wheel wear. See Maintenance - Guide Wheels, Allowable Wear.
7. Coat the spindle surface, grease seal surface, both bearing cup surfaces, pack both bearing cones and fill the guide wheel cavity 1/2 full (50 %) using Mobil HP grease, or equivalent.
8. Install the inner bearing cone (9) into the guide wheel (5). Install a new grease seal (11) into the wheel.
9. Slide the guide wheel (5) with the inner bearing (9) and grease seal (11) onto the spindle (6). Install the outer bearing cone (7), spindle washer (4) and 1-1/2 inch castle nut (3) onto the spindle (6).
10. Torque the castle nut (3) to approximately 20 ft lbs. Then loosen the castle nut. This is especially important if new bearing cups have been installed.
11. Torque the castle nut (3) to 7 ft lbs (zero clearance). Then back the castle nut off 1/2 to 1 flat of the nut (.001 - .010 inch clearance). Secure the castle nut using a new cotter pin (2).
12. Install the hub cap (1) onto the guide wheel.

4.3 Guide Wheel Equipment Lubrication

4.3.2 Re-Packing Guide Wheel Bearings

FIGURE 4-2
RE-PACKING GUIDE WHEEL BEARINGS

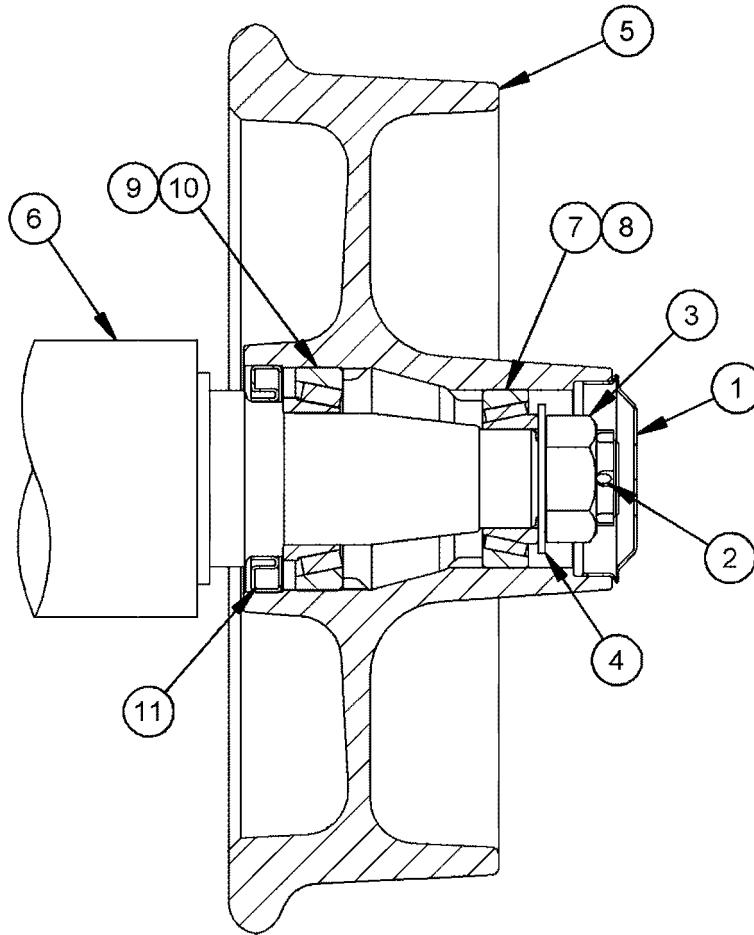

4.4 Guide Wheels

4.4.1 Allowable Wear - See Figure 4-3



- **REPLACE ANY GUIDE WHEEL IMMEDIATELY WHICH SHOWS DAMAGE AND/OR HAS WORN MORE THAN THE ALLOWABLE LIMITS. FAILURE TO COMPLY COULD RESULT IN DERAILMENT OF THE VEHICLE, AND SEVERE BODILY INJURY.**

The guide wheels must be checked for allowable wear a minimum of once yearly (every twelve months). Use the following procedure to check the guide wheel wear.

1. Tools needed: Harsco Rail wheel caliper (M019889), or equivalent.
2. Measure the guide wheel flange at Position "A" with the wheel caliper. The minimum allowable flange dimension at Position "A" is 7/8 inch (22.2 mm).

4

If the guide wheel flange dimension is less than the allowable limit, replace the guide wheel immediately.

3. Measure the guide wheel tread at Position "B" with the wheel caliper. The minimum allowable tread dimension at Position "B" is 1/2 inch (12.7 mm).

If the guide wheel tread dimension is less than the allowable limit, replace the guide wheel immediately.

4. The entire guide wheel must not have any gouges or cracks. If any of these are evident, replace the guide wheel immediately.

FIGURE 4-3
GUIDE WHEEL ALLOWABLE WEAR

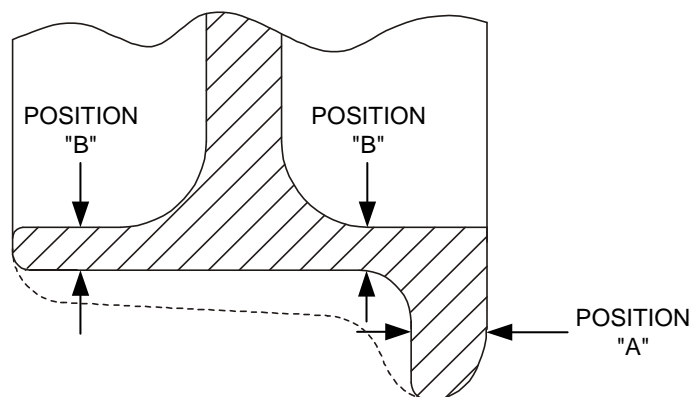

4.5 Vehicle Wheels

4.5.1 Tire Replacement



- **USE REPLACEMENT TIRES WITH THE SAME ROLLING RADIUS, TREAD WIDTH, PLY RATING, AND LOAD RATING AS RECOMMENDED BY THE VEHICLE MANUFACTURER. FAILURE TO COMPLY COULD RESULT IN BODILY INJURY AND/OR PROPERTY DAMAGE.**

Replacement tires must have the same rolling radius, tread width, ply rating, and load rating as recommended by the vehicle manufacturer. Using tires of equal diameter will help keep the speedometer reading and the guide wheel load accurate. Tires must have a minimum 6-1/2 inches of tread width. After installing new tire(s) on the vehicle, check guide wheel load. See the Adjustment Section - Guide Wheel Equipment Alignment Procedure.

Inflate tires to the tire manufacturer's recommended maximum pressure printed on the sidewalls of the tires or the wheel manufacturer's recommended maximum pressure stamped on the wheel, whichever is lower. The wheels and tires should be static balanced or balanced after installation on the vehicle for the best results. Torque vehicle wheel lug nuts to manufacturer's recommended specifications.

4

4.6 Bolt Torque Requirements



- **CHECK ALL BOLTS AND NUTS PERIODICALLY. KEEP BOLTS AND NUTS TIGHTENED TO THE TORQUE SPECIFIED IN APPENDIX A. IF BOLT REPLACEMENT BECOMES NECESSARY, REPLACE WORN BOLT WITH EQUAL S.A.E. GRADE NUMBER BOLT. FAILURE TO COMPLY COULD RESULT IN BODILY INJURY, AND/OR PROPERTY DAMAGE.**

See Appendix A for bolt torque specification tables and grade identification markings used by manufacturers.

4.7 Hoses and Fittings



- ALL HOSES AND FITTINGS ON THIS EQUIPMENT MUST COMPLY WITH SAE STANDARD J1273 RECOMMENDED PRACTICE FOR SELECTION, INSTALLATION AND MAINTENANCE OF HOSE AND HOSE ASSEMBLIES. FAILURE TO COMPLY TO THIS STANDARD COULD RESULT IN SEVERE BODILY INJURY.

4.7.1 Inspection, Maintenance, Replacement And Installation

The inspection, maintenance, replacement and installation of hydraulic hose assemblies and fittings on this equipment must conform with SAE Standard J1273. See Appendix B.

4.7.1 Hose Band - See Figure 4-4

All Harsco Rail original and replacement hose assemblies are supplied with a hose band displaying the date of manufacture and the Harsco Rail part number. The hose assembly illustrated in the example was manufactured in February 2011 and is Harsco Rail part number 188662.

4

FIGURE 4-4
HOSE BAND

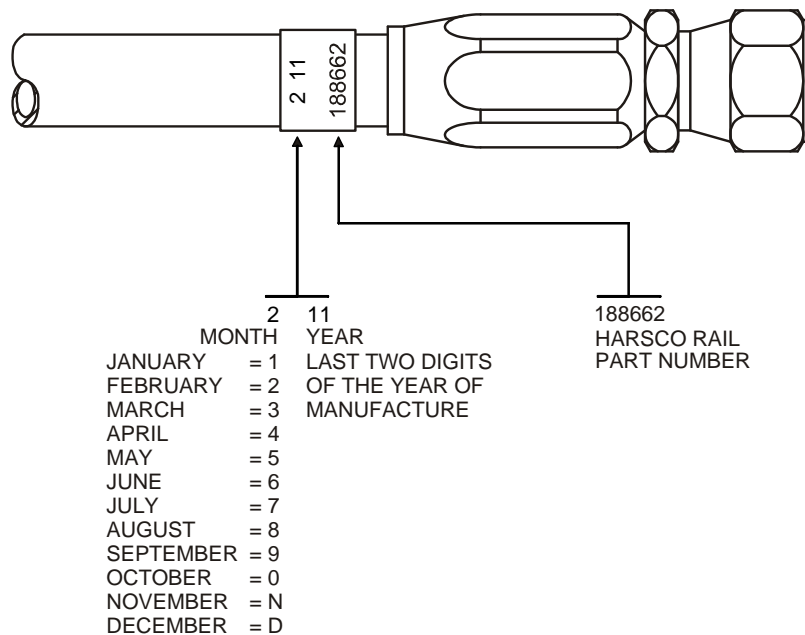

**SECTION 5 - TROUBLESHOOTING
TABLE OF CONTENTS**

5.1 Troubleshooting Guide Wheel Equipment. 5 - 2

5.1 Troubleshooting Guide Wheel Equipment

PROBLEM	PROBABLE CAUSE	POSSIBLE REMEDY
Hydraulic pump not delivering oil.	<p>Mechanical PTO not engaged or control valve not shifted to direct oil flow to guide wheel equipment.</p> <p>Hydraulic reservoir oil level low.</p> <p>Oil restricted to pump intake.</p> <p>Components bent, broken, worn, etc.</p>	<p>Engage mechanical PTO. Shift control valve to direct oil flow to guide wheel equipment.</p> <p>Fill reservoir to full level with recommended hydraulic oil.</p> <p>Check all strainers and filters for dirt and sludge. Clean and replace if necessary.</p> <p>Replace components.</p>
Guide wheel unit does not lower or raise.	<p>Lock engaged.</p> <p>Hydraulic pump not operating.</p> <p>Hydraulic reservoir oil level low.</p> <p>Components bent, broken, worn, etc.</p>	<p>Disengage lock. See Operation Section - Placing Vehicle On Track or Removing Vehicle From Track.</p> <p>Start hydraulic pump.</p> <p>Fill reservoir to full level with recommended hydraulic oil.</p> <p>Replace components.</p>
Guide wheel unit is difficult to lower or raise.	<p>Vehicle over-loaded.</p> <p>Guide wheel load adjusted incorrectly.</p> <p>Components bent, broken, worn, etc.</p> <p>Lack of lubrication.</p> <p>Control valve or flow divider valve relief pressure set incorrectly.</p>	<p>Remove excess load from vehicle.</p> <p>Adjust. See Adjustment Section.</p> <p>Replace components.</p> <p>Lubricate. See Maintenance Section.</p> <p>Check and adjust if necessary. See Adjustment Section.</p>

5.1 Troubleshooting Guide Wheel Equipment

PROBLEM	PROBABLE CAUSE	POSSIBLE REMEDY
<p>Lock pin cannot be inserted when guide wheel unit is in "rail" or "highway" position.</p>	<p>Foreign material (mud, slush, dirt, etc.) in locking mechanism.</p> <p>Locking mechanism adjusted incorrectly.</p> <p>Lack of lubrication.</p> <p>Components bent, broken, worn, etc.</p>	<p>Clean. See Maintenance Section.</p> <p>Re-adjust. See Adjustment Section.</p> <p>Lubricate. See Maintenance Section.</p> <p>Replace components.</p>
<p>Vehicle load exceeds rear Guide wheel unit maximum rated load.</p>	<p>Rear guide wheel unit not initially set to carry approximately 33% of vehicle rear axle load.</p> <p>Vehicle overloaded.</p> <p>Vehicle rear tires under inflated.</p> <p>Vehicle rear spring broken.</p>	<p>Adjust rear spring cells. See Adjustment Section.</p> <p>Redistribute or remove some of the load.</p> <p>Check pressure. Inflate if low. Do not exceed tire manufacturer's recommended maximum pressure printed on the sidewalls, or wheel manufacturer's recommended maximum pressure stamped on the wheel, whichever is lower.</p> <p>Repair / replace spring(s).</p>

5.1 Troubleshooting Guide Wheel Equipment

PROBLEM	PROBABLE CAUSE	POSSIBLE REMEDY
<p>Vehicle pulls noticeably to the left or right when on track.</p>	<p>Vehicle loaded heavy on one side.</p> <p>Guide wheel units, vehicle rear axle, etc. not aligned with vehicle frame.</p> <p>Incorrect or worn vehicle rear tire.</p> <p>Vehicle rear tires under inflated.</p> <p>Guide wheel brake shoes dragging.</p>	<p>Move load to center of vehicle.</p> <p>Check alignment. See Adjustment Section - Guide Wheel Equipment Alignment Procedure.</p> <p>Check for correct rear tire. Replace if necessary. Replace worn rear tire.</p> <p>Check pressure. Inflate if low. Do not exceed tire manufacturer's recommended maximum pressure printed on the sidewalls, or wheel manufacturer's recommended maximum pressure stamped on the wheel, whichever is lower.</p> <p>Re-adjust brake shoes. See Adjustment Section - Brake Shoe Clearance.</p>
<p>Vibration felt in the vehicle when traveling on track.</p>	<p>Guide wheel unit mounting fasteners loose.</p> <p>Guide wheel bearings worn.</p> <p>Guide wheels worn.</p> <p>Vehicle rear rim bent.</p> <p>Vehicle rear tires out of balance.</p>	<p>Tighten all bolts to recommended torque.</p> <p>Replace bearings, wheel or axle.</p> <p>Check guide wheel wear. See Maintenance Section - Guide Wheels, Allowable Wear.</p> <p>Replace. See vehicle manufacturer.</p> <p>Balance tires.</p>

5.1 Troubleshooting Guide Wheel Equipment

PROBLEM	PROBABLE CAUSE	POSSIBLE REMEDY
<p>Vibration felt in the vehicle when traveling on highway.</p>	<p>Guide wheel unit mounting fasteners loose.</p> <p>Guide wheel unit not locked in "highway" position.</p> <p>Vehicle rim bent.</p> <p>Vehicle tires out of balance.</p>	<p>Tighten all bolts to recommended torque.</p> <p>STOP IMMEDIATELY. Make sure both guide wheel units are locked in "highway" position.</p> <p>Replace. See vehicle manufacturer.</p> <p>Balance tires.</p>
<p>Vehicle derails.</p>	<p>Guide wheel units, vehicle rear axle, etc. not aligned with vehicle frame.</p>	<p>Check alignment. See Adjustment Section - Guide Wheel Equipment Alignment Procedure.</p>

NOTES

5

**SECTION 6 - PARTS
TABLE OF CONTENTS**

Serial Numbers 6 - 2

Instructions For Ordering Parts 6 - 3

HR4000A2 Rear Guide Wheel Unit - Insulated With Side Shift - 157712 6 - 4

HR4000A2 Rear Guide Wheel Unit - Non-Insulated With Side Shift - 158145 6 - 4

 Axle Assembly - 174351 6 - 5

 Upper Frame Assembly - Units With Side Shift - 157292 6 - 6

 Hydraulic Piping 6 - 9

HR4000A2 Rear Guide Wheel Unit - Insulated Without Side Shift - 161282 6 - 10

HR4000A2 Rear Guide Wheel Unit - Non-Insulated With Side Shift - 162127 6 - 10

 Axle Assembly - 174351 6 - 11

 Upper Frame Assembly - Units Without Side Shift - 159940 6 - 12

 Hydraulic Piping 6 - 15

HR4000A2 Guide Wheel Assembly 6 - 16

Steering Lock Groups 6 - 17

Hydraulic Lock Conversion Group - 198747 6 - 18

Rear Rail Sweep Group - 158663 6 - 20

Rear Unit Brake Group - With Side Shift - 158185 6 - 21

Rear Unit Brake Group - Without Side Shift - 161300 6 - 22

Rear Unit Brake Air Piping 6 - 23

Truck Brake Connection - 154057 6 - 24

Truck Brake Connection - 154388 6 - 26

Truck Brake Connection - 162114 6 - 28

Truck Brake Connection - 162130 6 - 30

Truck Brake Connection - 179161 6 - 32

Hydraulic Power Pack, Full - 137926 6 - 34

Hydraulic Power Pack, Abbreviated - 137927 6 - 38

Sight Rod Extension Group - 164574 6 - 40

Decal Service Group - Insulated Units - 157310 6 - 40

Decal Service Group - Non-Insulated Units - 159438 6 - 40

Serial Numbers

When this bulletin is received, complete the following record from the serial number tag on the rear guide wheel units. Always mention these factory serial numbers when calling or writing about the unit. The serial number tag is located on the frame assembly of the unit.

FIGURE 1
REAR UNIT SERIAL NUMBER PLATE

HARSCO

PATENT NUMBER

WHEN ORDERING PARTS FOR THIS ACCESSORY ALWAYS GIVE THE FOLLOWING INFORMATION

HY-RAIL® GUIDE WHEEL EQUIPMENT

SERIAL NUMBER **SYMBOL** **MODEL NUMBER**

COLUMBIA, S.C. 29171 U.S.A.

82400K

Instructions For Ordering Parts

1. See Section 7 for the Vehicle Application charts.
2. Find the chart for the make, model and year of the vehicle that the unit is mounted on.
3. Each application consists of required groups, optional groups required and accessory group options. These are the group numbers that were supplied with, or that were available for the unit.
4. Locate the appropriate group numbers in the Parts Section to find the individual parts required.
5. Front - rear and left - right are determined from the vehicle operator's seat.
6. Assemblies: Items listed in CAPITALS are assemblies which include all parts listed immediately following and indented to the right. When assemblies can be used, always order them to save work of fitting separate parts.
7. For convenience in ordering, parts are listed by item number, part number, description, and quantity in each assembly or group. If in doubt as to any part wanted, send full description, digital photograph, sketch, or send the old part with the order.
8. To insure prompt and correct shipment of parts on orders, always give:
 - a. Quantity of each part wanted.
 - b. Part number of each part as shown in this book. Include any prefix and suffix letters.
 - c. Description of each part as shown in this book.
 - d. Factory serial numbers recorded above.
 - e. Purchase order number (if required).
 - f. Preferred method of shipment.
9. All parts are shipped F.O.B. factory, transportation charges to be paid by customer. Terms to be determined by the Credit Department.

HR4000A2 Rear Guide Wheel Unit - Insulated With Side Shift - 157712
HR4000A2 Rear Guide Wheel Unit - Non-Insulated With Side Shift - 158145

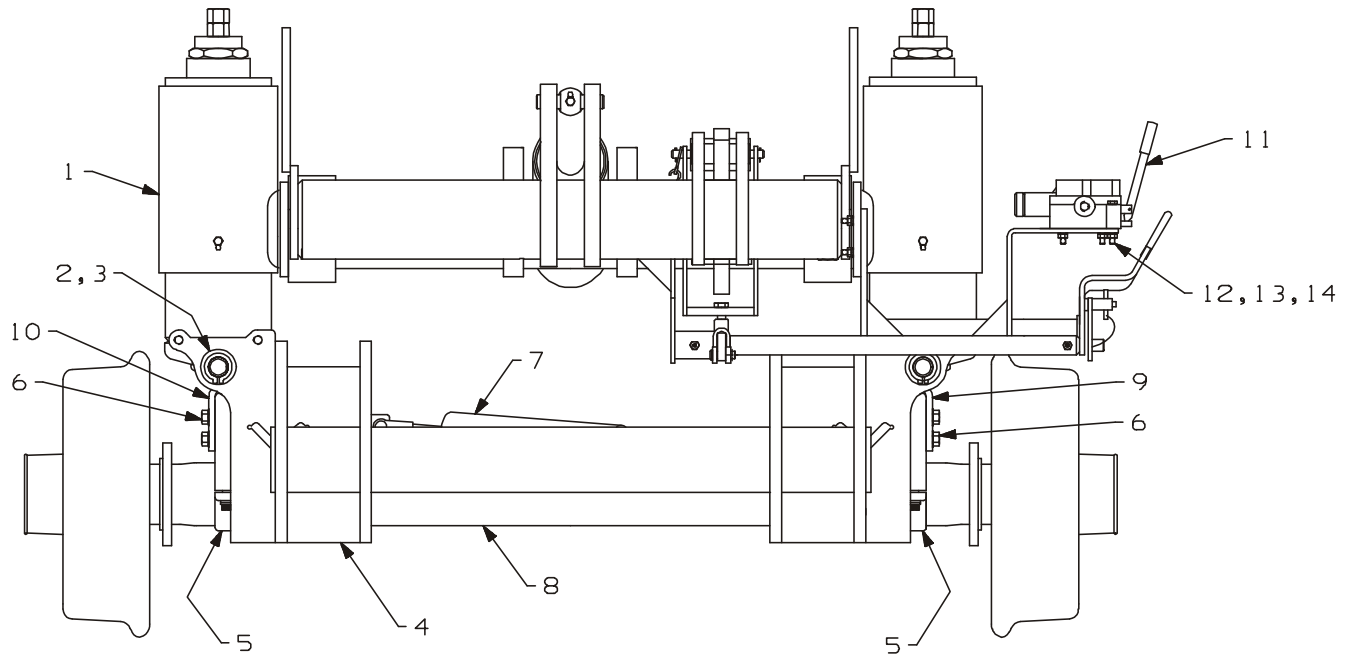

HR4000A2 Rear Guide Wheel Unit - Insulated With Side Shift - 157712
HR4000A2 Rear Guide Wheel Unit - Non-Insulated With Side Shift - 158145

ITEM	PART NO	DESCRIPTION	QTY
1	157292	Upper Frame Assembly	1
2	157241	Pin	2
3	700843015	Retaining Ring	4
4	157692	Lower Frame	1
5	157680	Axle Clamp.	2
6	F022036	Cap Screw, 1/2-13 x 1-1/4" GR 5 Hex Flg Hd	8
7	189129	HYDRAULIC CYLINDER (Mounting Pins and Clips Included	1
	189130	Seal Kit	1
8	174351	AXLE ASSEMBLY (Insulated or Non-Insulated)	1
	F003150	Cotter Pin, 3/16 x 2-1/2".	2
	F025249	Hex Slotted Nut, 1-1/2"-12.	2
9	157681	Strap	1
10	157689	Strap	1
11	F019081	Control Valve, Side Shift	1
12	F013428	Cap Screw, 5/16-18 x 2-1/2" Hex Hd	3
13	F001100	SAE Lock Washer, 5/16"	3
14	F007021	Hex Nut, 5/16"-18 GR 5	3

174351 Axle Assembly

The illustration below displays the factory welding procedure performed on the 174351 Axle Assembly that is used to make the Guide Wheel Unit Non-Insulated.

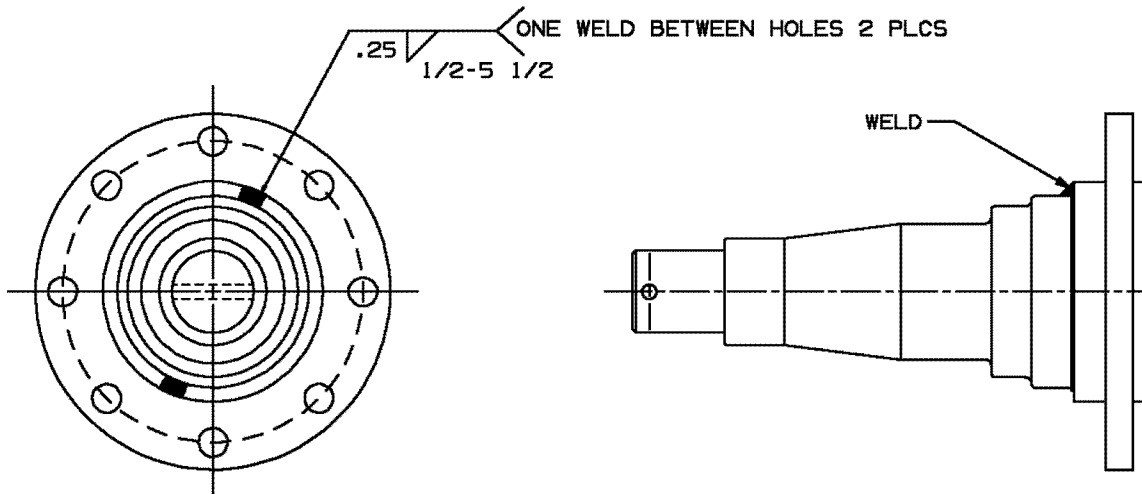

157292 Upper Frame Assembly - Units With Side Shift

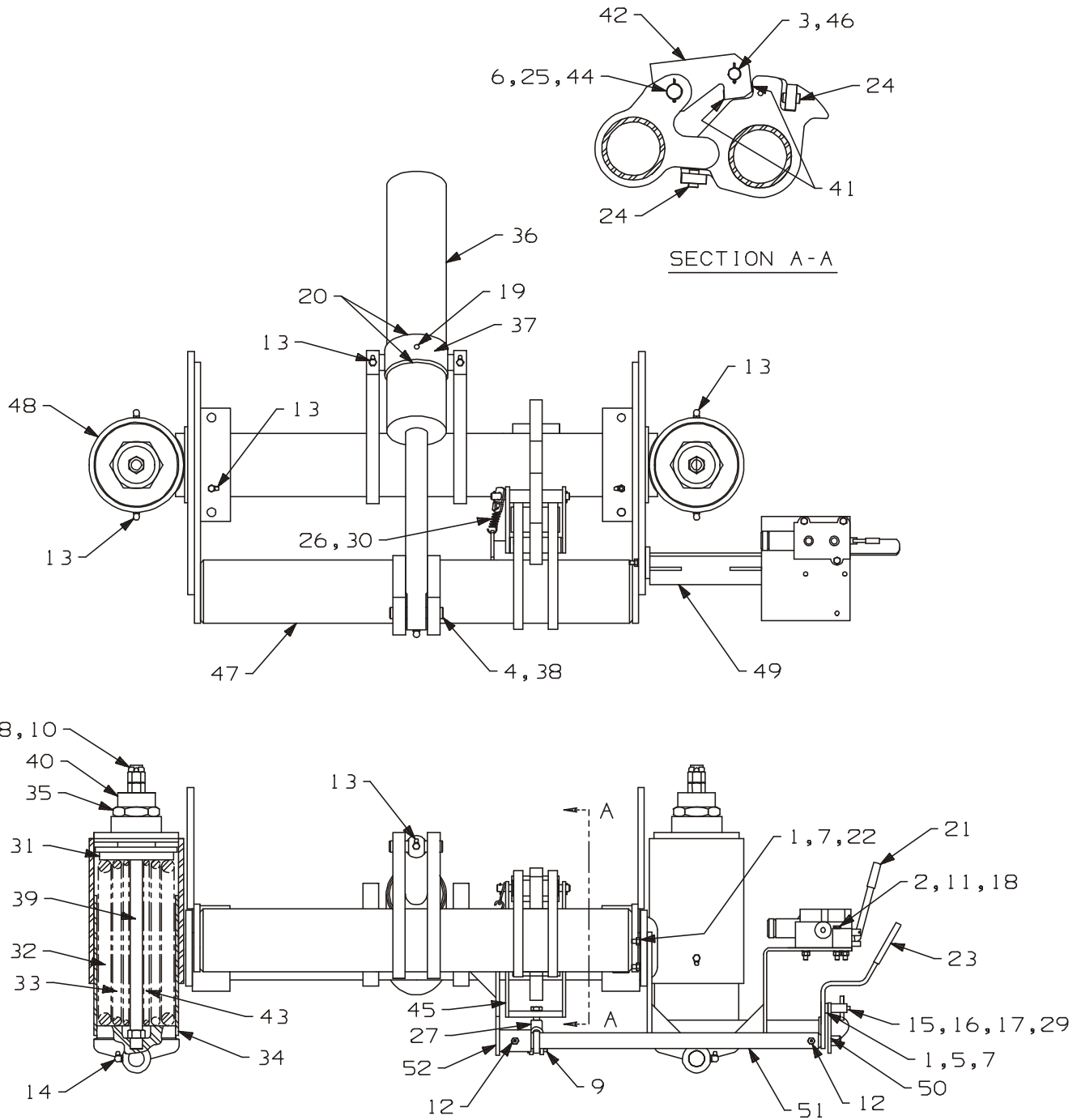

157292 Upper Frame Assembly - Units With Side Shift

ITEM	PART NO	DESCRIPTION	QTY
1	F001075	SAE Lock Washer, 1/2"	4
2	F001100	SAE Lock Washer, 5/16"	3
3	F001104	Cotter Pin, 1/8 X 1"	2
4	F001182	Cotter Pin, 1/8 x 1-1/4"	2
5	F001442	Cap Screw, 1/2-13 x 2" GR 5 Hex Hd	2
6	F002547	Cotter Pin, 1/8 x 2"	2
7	F003598	Hex Nut, 1/2"-13 GR 5	4
8	F004344	Cotter Pin, 3/16 x 2"	2
9	F005460	Yoke Pin Assembly	1
10	F006657	Hex Castle Nut, 1"-14.	2
11	F007021	Hex Nut, 5/16"-18 GR 5	3
12	F008014	Grease Fitting.	2
13	F009217	Grease Fitting, 90° Elbow X 2 NPT	9
14	F009420	Grease Fitting, 45° Elbow x 2 NPT	4
15	F009541	SAE Lock Washer, #10	1
16	F009542	Hex Nut, #10-24 GR 2	1
17	F009591	Machine Screw, #10-24 x 3/4" Rd Hd	1
18	F013428	Cap Screw, 5/16-18 x 2-1/2" Hex Hd	3
19	F014224	Set Screw, 3/8-16 x 3/8" Locking Cup Pt Soc Hd.	1
20	F016485	Retaining Ring	2
21	F018510	Control Valve	1
22	F019634	Cap Screw, 1/2-13 x 1-3/4" Flt Soc Hd.	2
23	F022846	Handle Grip	1
24	F023736	Set Screw, 3/4-10 x 1-1/2" Oval Pt Soc Hd	4
25	M004458	Washer.	3
26	M010612	Spring.	1
27	M033360K1	Yoke	1
28	069859	Sleeve	2
29	081645K	Lockpin & Lanyard	1
30	089216	Link	1
31	099369	Washer.	2
32	099370	Spring.	2
33	099371	Spring.	2
34	099373	Spring Housing.	2
35	099378	Nut	2
36	099394K	HYDRAULIC CYLINDER	1
	188632	Seal Kit	1
37	099402K	Cylinder Mounting	1
38	105030	Pin	1
39	111065	Rod	2
40	111067	Adjusting Stud	2
41	113535	Spacer (weld on as needed for lock adjustment	4
42	136276	Lock	1
43	140109	Spring.	2
44	140157	Lock Pin	1

157292 Upper Frame Assembly - Units With Side Shift

ITEM	PART NO	DESCRIPTION	QTY
45	140175	Yoke Assembly.....	1
46	140176	Pin	1
47	157293	FRAME MOUNTING UNIT.....	1
	F001354	SAE Lock Washer, 3/4"	2
	F006382	Cap Screw, 3/4-10 x 2-1/2" Hex Hd.....	2
48	157295	CROSS TUBE	1
	F001075	SAE Lock Washer, 1/2"	2
	F003095	Cap Screw, 1/2-13 x 2-3/4" Hex Hd.....	2
49	157707K	Bracket.....	1
50	158676	Bracket Assembly	1
51	158679	Handle and Shaft Assembly.....	1
52	159016	Bracket.....	1

HR4000A2 Rear Guide Wheel Unit - Insulated With Side Shift - 157712
HR4000A2 Rear Guide Wheel Unit - Non-Insulated With Side Shift - 158145
Hydraulic Piping

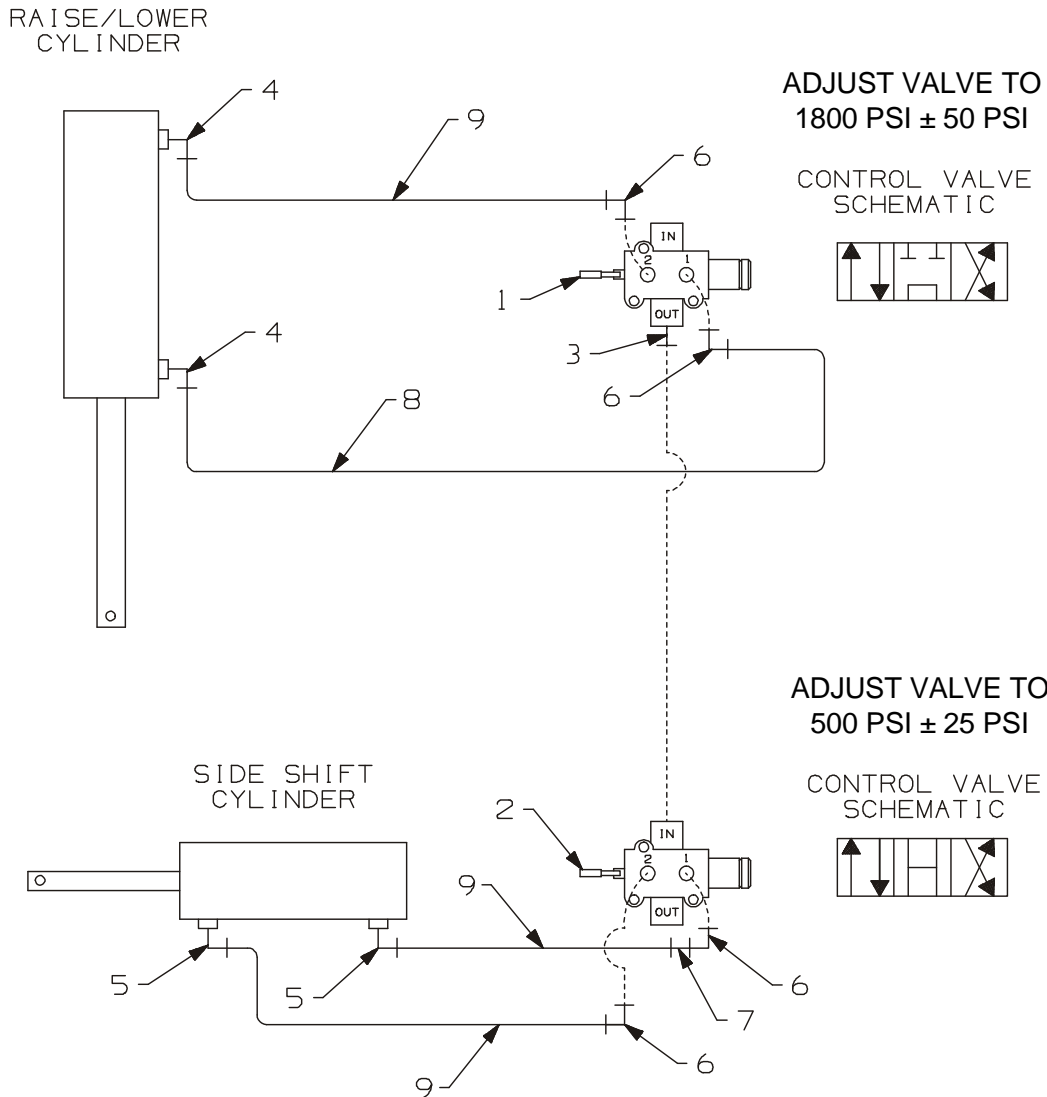

ITEM	PART NO	DESCRIPTION	QTY
1	F018510	Control Valve (Guide Wheels Raise/Lower)	1
2	F019081	Control Valve (Side Shift)	1
3	F011604	Adapter, 6 NPT x 6 NPT	1
4	F010987	90° Elbow, 6 x 2 NPT	2
5	F010988	90° Elbow, 6 x 4 NPT	2
6	F012055	90° Elbow, 6 JIC x 6 NPT	4
7	F024769	Restrictor	1
8	174935	Hose Assembly	1
9	197914	Hose Assembly	3

HR4000A2 Rear Guide Wheel Unit - Insulated Without Side Shift - 161282
HR4000A2 Rear Guide Wheel Unit - Non-Insulated Without Side Shift - 162127

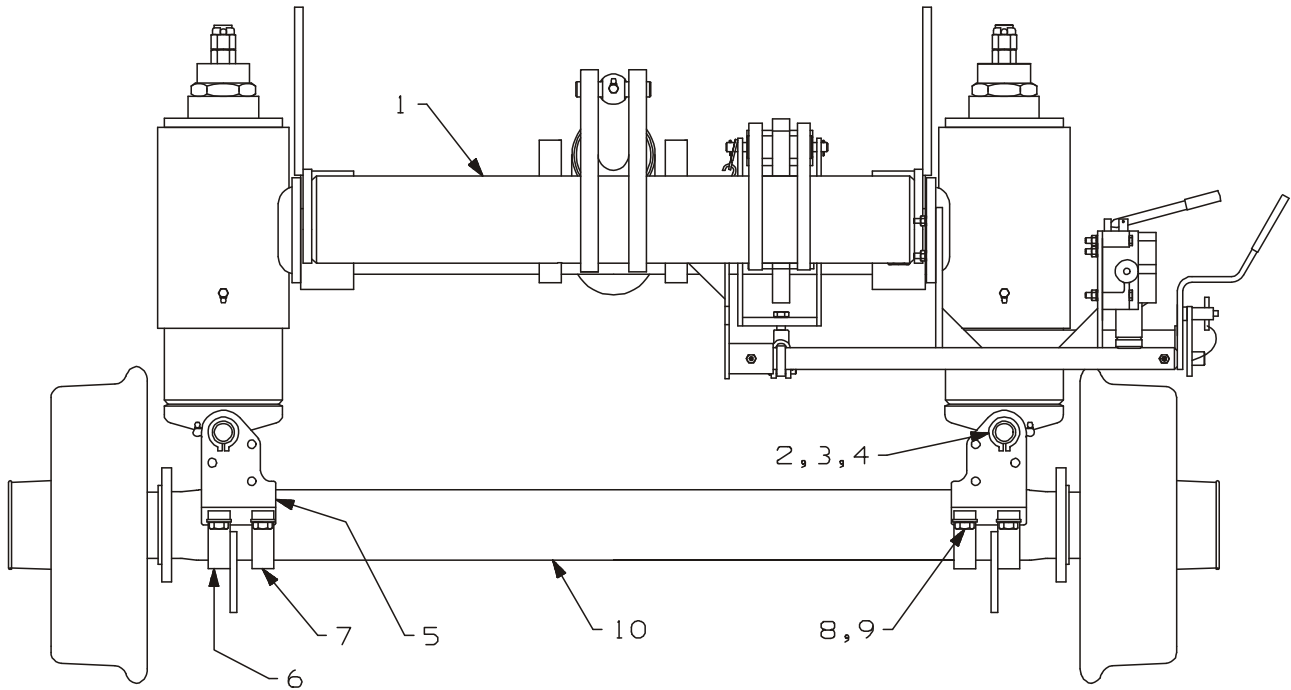

6

ITEM	PART NO	DESCRIPTION	QTY
1	159940	Upper Frame Assembly	1
2	157241	Pin	2
3	F008711	Wrought Washer	8
4	700843015	Retaining Ring	4
5	161287	Axle Clamp.	2
6	164512	Strap	2
7	163999	Strap	2
8	F001103	SAE Lock Washer, 5/8"	8
9	F019501	Cap Screw, 5/8-11 x 1-3/4" GR 8 Hex Hd	8
10	174351	AXLE ASSEMBLY (Insulated or Non-Insulated)	1
	F003150	Cotter Pin, 3/16 x 2-1/2".	2
	F025249	Hex Slotted Nut, 1-1/2"-12.	2

HR4000A2 Rear Guide Wheel Unit - Insulated Without Side Shift - 161282
HR4000A2 Rear Guide Wheel Unit - Non-Insulated Without Side Shift - 162127

174351 Axle Assembly

The illustration below displays the factory welding procedure performed on the 174351 Axle Assembly that is used to make the Guide Wheel Unit Non-Insulated.

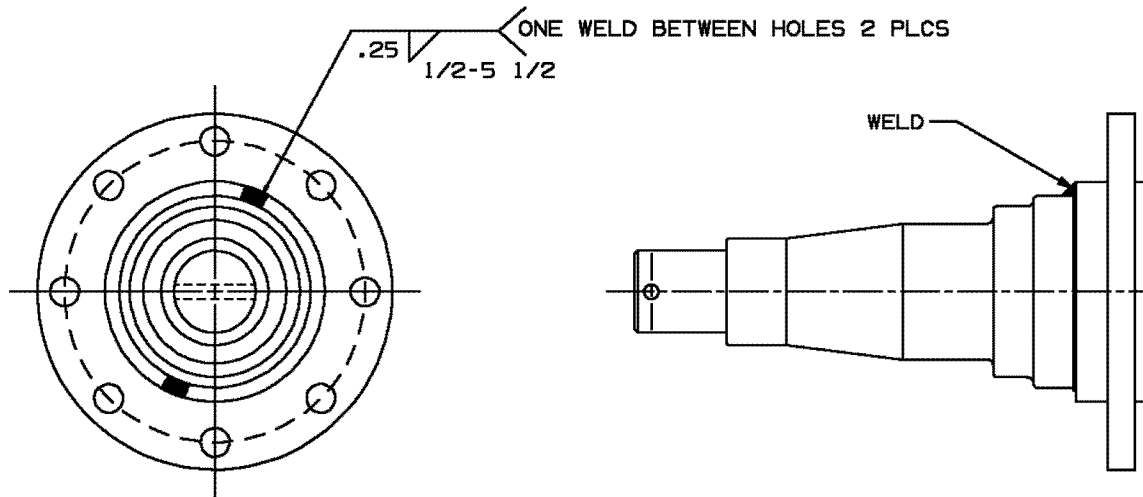

159940 Upper Frame Assembly - Units Without Side Shift

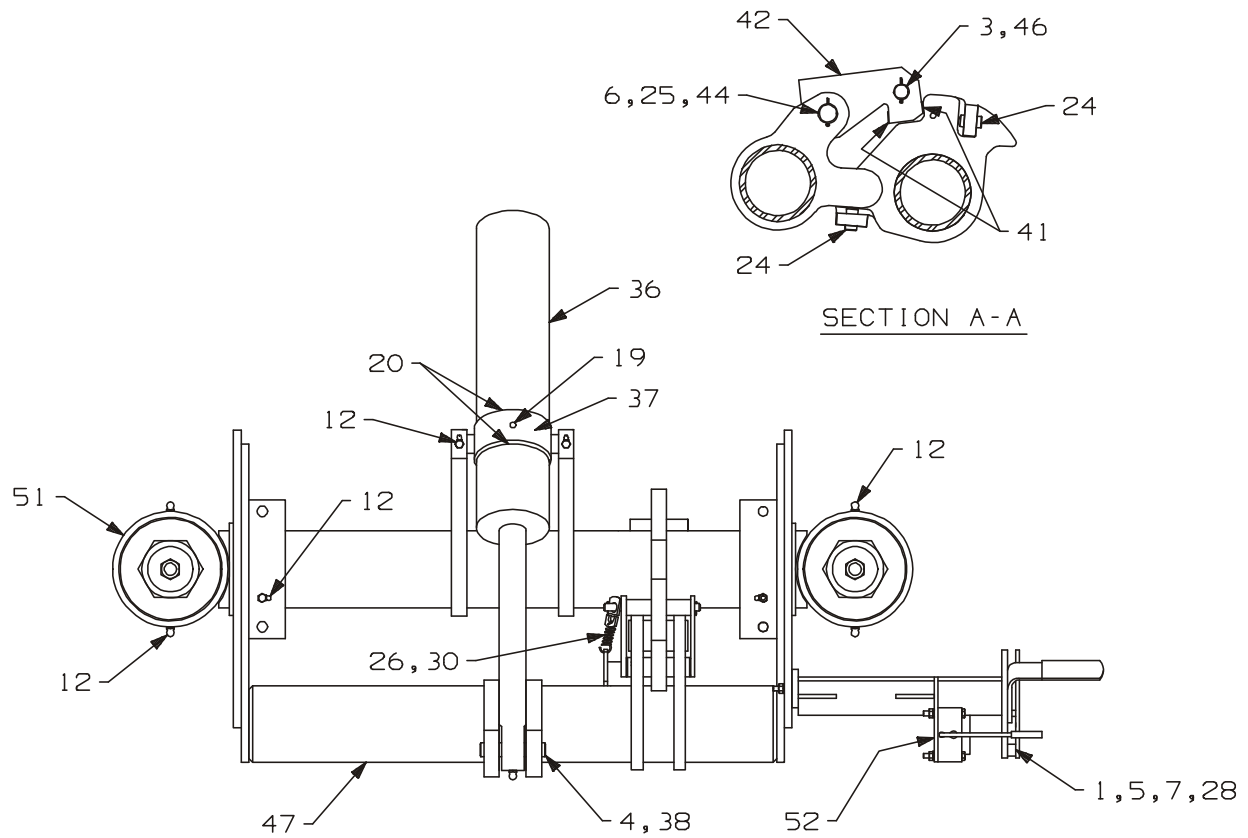

6

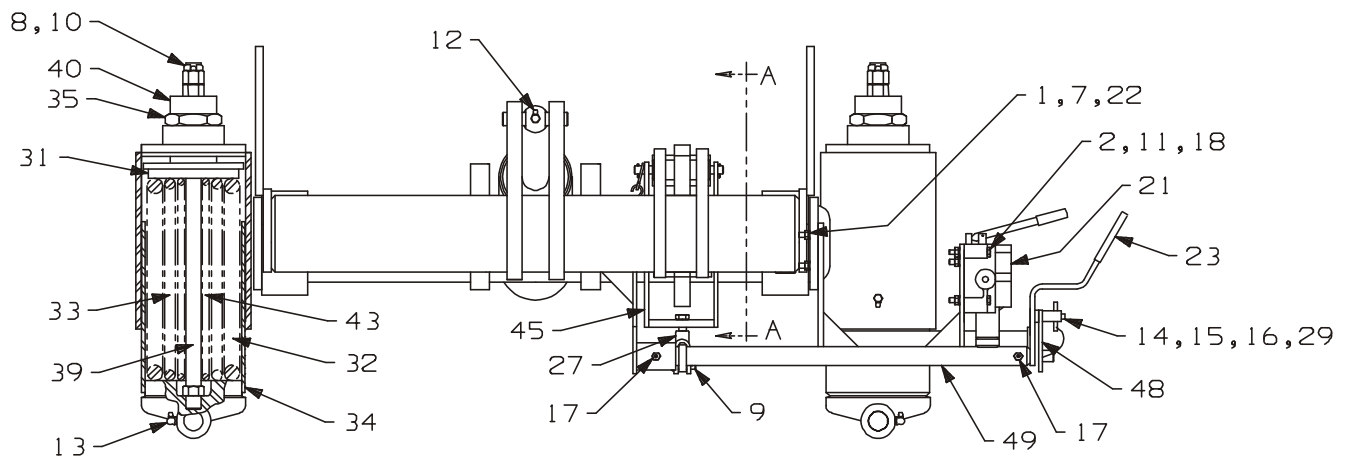

159940 Upper Frame Assembly - Units Without Side Shift

ITEM	PART NO	DESCRIPTION	QTY
1	F001075	SAE Lock Washer, 1/2"	4
2	F001100	SAE Lock Washer, 5/16"	3
3	F001104	Cotter Pin, 1/8 x 1"	2
4	F001182	Cotter Pin, 1/8 x 1-1/4"	2
5	F001442	Cap Screw, 1/2-13 x 2" GR 5 Hex Hd	2
6	F002547	Cotter Pin, 1/8 x 2"	2
7	F003598	Hex Nut, 1/2"-13 GR 5	4
8	F004344	Cotter Pin, 3/16 x 2"	2
9	F005460	Yoke Pin Assembly	1
10	F006657	Hex Castle Nut, 1"-14	4
11	F007021	Hex Nut, 5/16"-18 GR 5	3
12	F009217	Grease Fitting, 90° Elbow X 2 NPT	9
13	F009420	Grease Fitting, 45° Elbow x 2 NPT	4
14	F009541	SAE Lock Washer, #10	1
15	F009542	Hex Nut, #10-24 GR 2	1
16	F009591	Machine Screw, #10-24 x 3/4" Rd Hd	1
17	F010722	Grease Fitting, 90° Elbow x 1/4"-28	2
18	F013428	Cap Screw, 5/16-18 x 2-1/2" Hex Hd	3
19	F014224	Set Screw, 3/8-16 x 3/8" Locking Cup Pt Soc Hd.	1
20	F016485	Retaining Ring	2
21	F018510	Control Valve	1
22	F019634	Cap Screw, 1/2-13 x 1-3/4" Flt Soc Hd.	2
23	F022846	Handle Grip	1
24	F023736	Set Screw, 3/4-10 x 1-1/2" Oval Pt Soc Hd	4
25	M004458	Washer	8
26	M010612	Spring	1
27	M033360K1	Yoke	1
28	069859	Sleeve	2
29	081645K	Lockpin & Lanyard	1
30	089216	Link	1
31	099369	Washer	2
32	099370	Spring	2
33	099371	Spring	2
34	099373	Spring Housing	2
35	099378	Nut	2
36	099394K	HYDRAULIC CYLINDER	1
	188632	Seal Kit	1
37	099402K	Cylinder Mounting	1
38	105030	Pin	1
39	111065	Rod	2
40	111067	Adjusting Stud	2
41	113535	Spacer (weld on as needed for lock adjustment	4
42	136276	Lock	1
43	140109	Spring	2
44	140157	Lock Pin	1

159940 Upper Frame Assembly - Units Without Side Shift

ITEM	PART NO	DESCRIPTION	QTY
45	140175	Yoke	1
46	140176	Pin	1
47	157293	FRAME MOUNTING UNIT.....	1
	F001354	SAE Lock Washer, 3/4"	2
	F006382	Cap Screw, 3/4-10 x 2-1/2" Hex Hd.....	2
48	158676	Bracket Assembly	1
49	158679	Handle Assembly	1
50	159016	Bracket Assembly	1
51	159870	CROSS TUBE ASSEMBLY	1
	F001075	SAE Lock Washer, 1/2"	2
	F003095	Cap Screw, 1/2-13 x 2-3/4" Hex Hd.....	2
52	161303	Bracket.....	1

HR4000A2 Rear Guide Wheel Unit - Insulated Without Side Shift - 161282
HR4000A2 Rear Guide Wheel Unit - Non-Insulated Without Side Shift - 162127
Hydraulic Piping

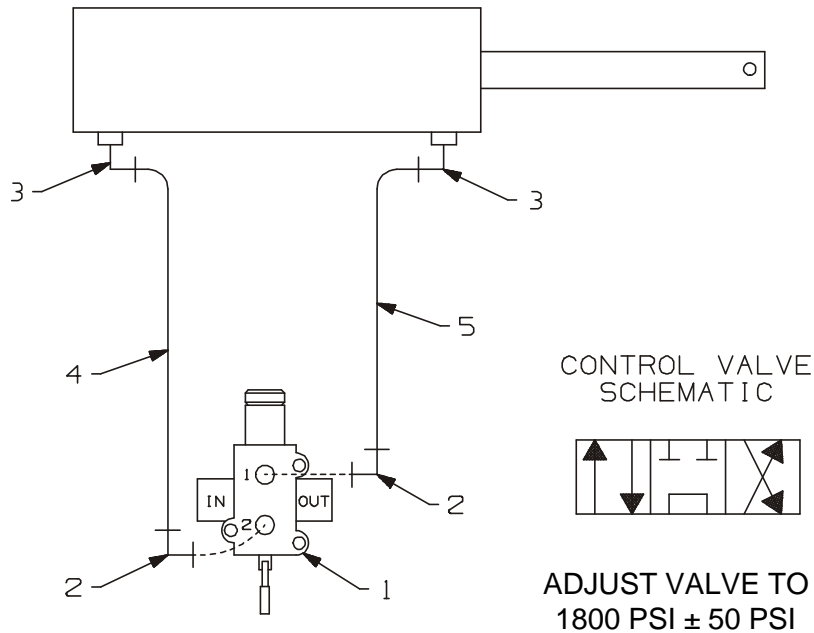

ITEM	PART NO	DESCRIPTION	QTY
1	F018510	Control Valve	1
2	F012055	90° Elbow, 6 x 6 NPT	2
3	F010987	90° Elbow, 6 x 2 NPT	2
4	197914	Hose Assembly	1
5	174935	Hose Assembly	1

HR4000A2 Guide Wheel Assembly

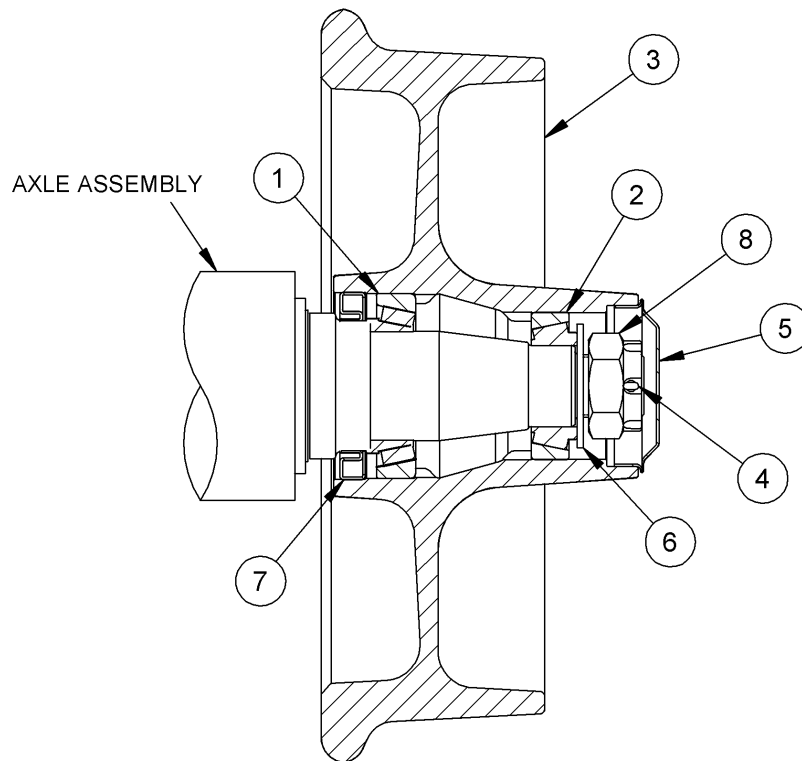

HR4000A2 Guide Wheel Assembly

Note: Quantities listed are for one wheel only.

ITEM	PART NO	DESCRIPTION	QTY
1	159507	Bearing Cup and Cone, Inside	1
2	159508	Bearing Cup and Cone, Outside	1
3	175661	Wheel, Non-Insulated.	1
4	F003150	Cotter Pin, 3/16 x 2-1/2"	1
5	F025011	Grease Cap	1
6	F025049	Washer.	1
7	F025057	Grease Seal	1
8	F025249	Hex Slotted Nut, 1-1/2"-12	1

Steering Lock Groups

Individual steering lock components are not available as repair parts. Steering lock groups are sold as complete replacement groups only. See vehicle application charts to find the correct steering lock group applicable to your make, model and year of vehicle.

Hydraulic Lock Conversion Group - 198747

ITEM	PART NO	DESCRIPTION	QTY
	198747	REAR HYDRAULIC LOCK CONVERSION GROUP	1
1	198670	Pin	1
2	198668	Hydraulic Cylinder	1
3	198671	Yoke Weldment	1
4	198672	Valve Bracket (weld on existing valve bracket)	1
5	198669	Control Valve	1
6	173116	Cap Screw, 1/2"-20 x 2-1/2"	1
7	F010606	Hex Lock Nut, 1/2"-20	1
8	F015104	90° Elbow, 7/16"-20 JIC x 3/8 NPT	2
9	F011604	Adapter, 3/8" NPT x 3/8" NPT	1
10	410861	Hose Assembly	2
11	F001104	Cotter Pin, 1/8" x 1"	2
12	F013428	Cap Screw, 5/16"-18 x 2-1/2" Hex Hd	3
13	F040088	Hex Flange Nut, 5/16"-18	3
14	F014734	90° Elbow, 7/16"-20 x JIC x 7/16"-20 SAE	2

6

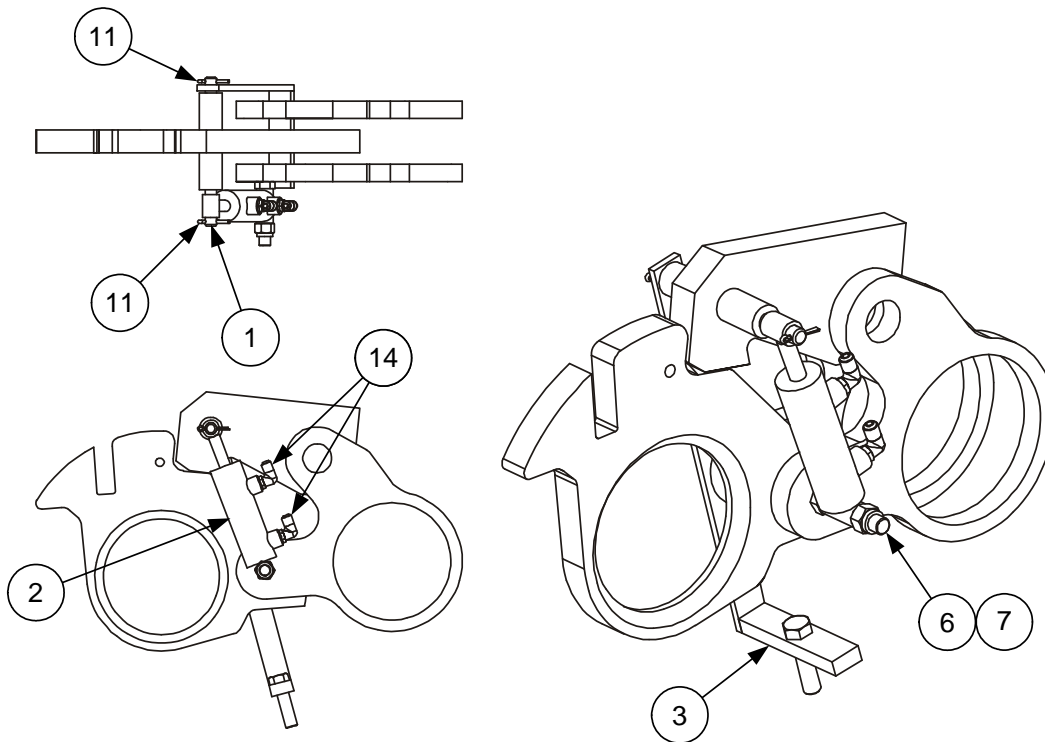

Hydraulic Lock Conversion Group - 198747

NOTE:
COMPONENTS WITHOUT ITEM NUMBERS ARE EXISTING

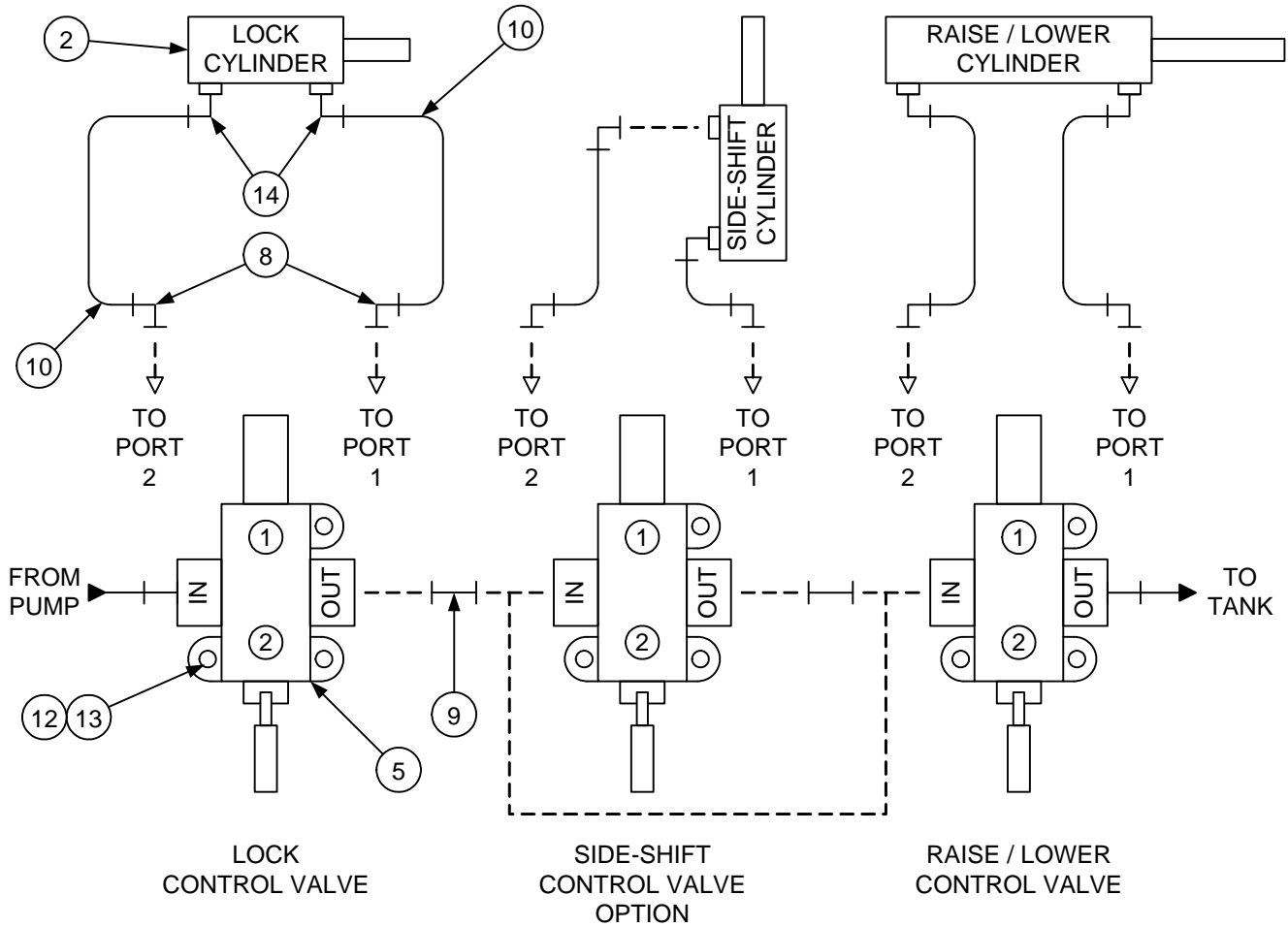

Rear Rail Sweep Group - 158663

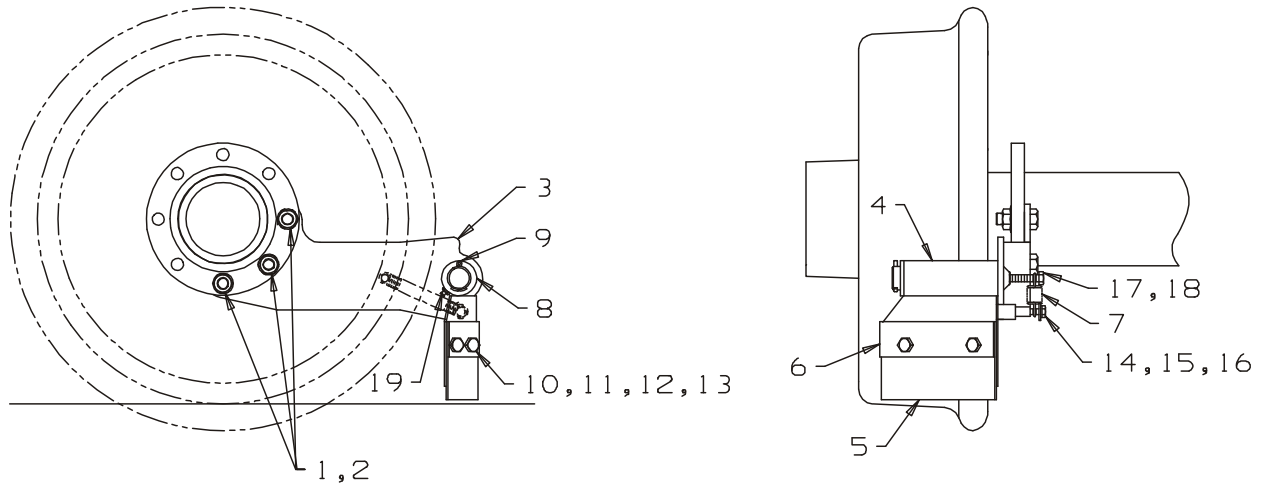

6

ITEM	PART NO	DESCRIPTION	QTY
1	F001095	Cap Screw, 1/2-13 x 1-3/4" Hex Hd	2
2	F022037	Hex Flg Nut, 1/2"-13.	2
	158383	RAIL SWEEP ASSEMBLY, RIGHT	1
	158384	RAIL SWEEP ASSEMBLY, LEFT.	1
3	158653	Mounting Bracket Right	1
	158654	Mounting Bracket Left	1
4	108505	Rail Sweep Plate, Right.	1
	108513	Rail Sweep Plate, Left	1
5	108509K1	Rail Sweep.	1
6	108510	Bracket.	1
7	072909	Spring.	1
8	179117	Washer.	1
9	F003141	Cotter Pin, 1/8 x 1-1/2".	1
10	F001125	Cap Screw, 3/8-16 x 1-1/4" Hex Hd.	2
11	F001115	Wrought Washer, 3/8"	2
12	F001025	SAE Lock Washer, 3/8"	2
13	F007020	Hex Nut, 3/8"-16	2
14	F002355	Cap Screw, 1/4-20 x 3/4" Hex Hd	1
15	F001106	Wrought Washer, 1/4"	1
16	F009535	Lock Washer, 1/4"	1
17	F007021	Hex Nut, 5/16"-18	1
18	F001113	Cap Screw, 5/16-18 x 1-1/4" Hex Hd.	1
19	F008014	Grease Fitting	1

Rear Unit Brake Group - With Side Shift - 158185

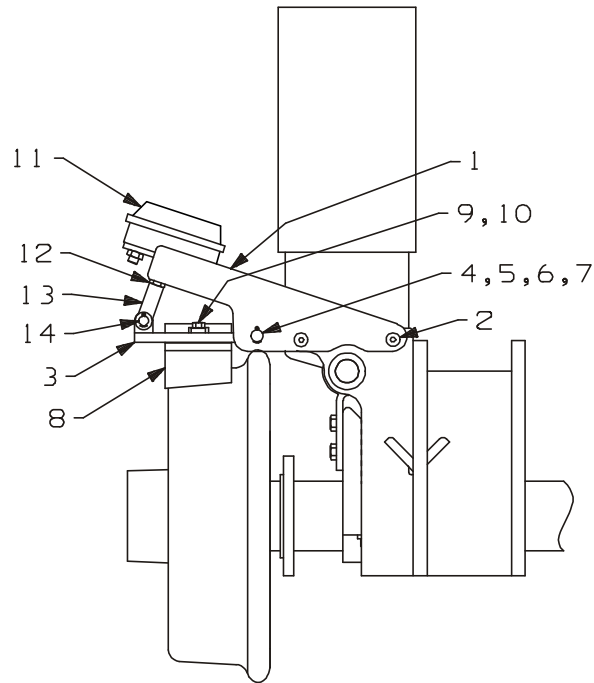

ITEM	PART NO	DESCRIPTION	QTY
1	157702	Bracket	2
2	F019634	Cap Screw, 1/2-13 x 1-3/4" Flt Soc Hd	8
3	157701	Plate	2
4	157698	Pin	2
5	M033847	Washer	8
6	F001182	Cotter Pin, 1/8 x 1-1/4"	4
7	F008014	Grease Fitting	4
8	0-3683003-0-04	Brake Shoe	2
9	157694	Link	2
10	F023416	Cap Screw, 3/8-16 x 3/4" Hex Flg Hd	4
11	F025058	Actuator	2
12	F011013	Hex Jam Nut, 1/2"-20	2
13	F005459	Yoke End	2
14	F005460	Yoke Pin With Cotter Pin	2

Rear Unit Brake Group - Without Side Shift - 161300

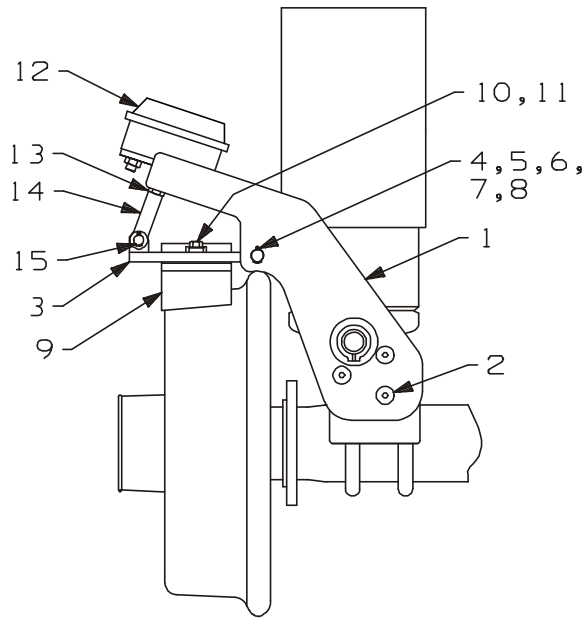

6

ITEM	PART NO	DESCRIPTION	QTY
1	159628	Bracket	2
2	149427	Cap Screw, 1/2-13 x 1" Flt Soc Hd.	8
3	157701	Plate	2
4	159918	Pin	2
5	M033847	Washer	8
6	F001182	Cotter Pin, 1/8 x 1-1/4"	4
7	F008014	Grease Fitting	4
8	159919	Tube	4
9	0-3683003-0-04	Brake Shoe	2
10	157694	Link	2
11	F023416	Cap Screw, 3/8-16 x 3/4" Hex Flg Hd	4
12	F025058	Actuator	2
13	F011013	Hex Jam Nut, 1/2"-20	2
14	F005459	Yoke End	2
15	F005460	Yoke Pin With Cotter Pin	2

Rear Unit Brake Air Piping

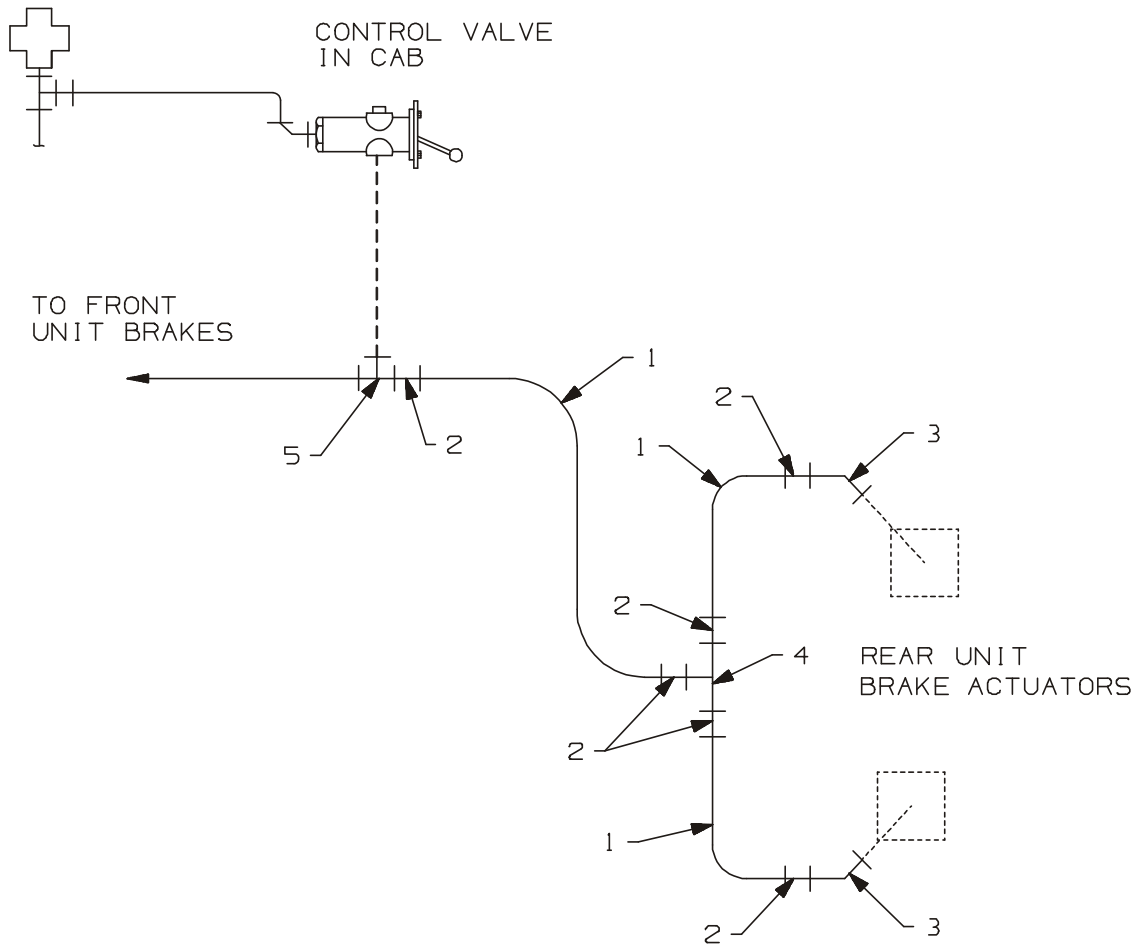

ITEM	PART NO	DESCRIPTION	QTY
1	F010693	Hose, 5/16" I.D.	360"
2	F018064	Swivel Hose Fitting.	12
3	F018562	45° Elbow, 6 x 6 NPT.	2
4	F011260	Tee, 6 x 6 x 6.	1
5	F011072	Tee, 6 x 6 x 4 NPT.	1

154057 Truck Brake Connection

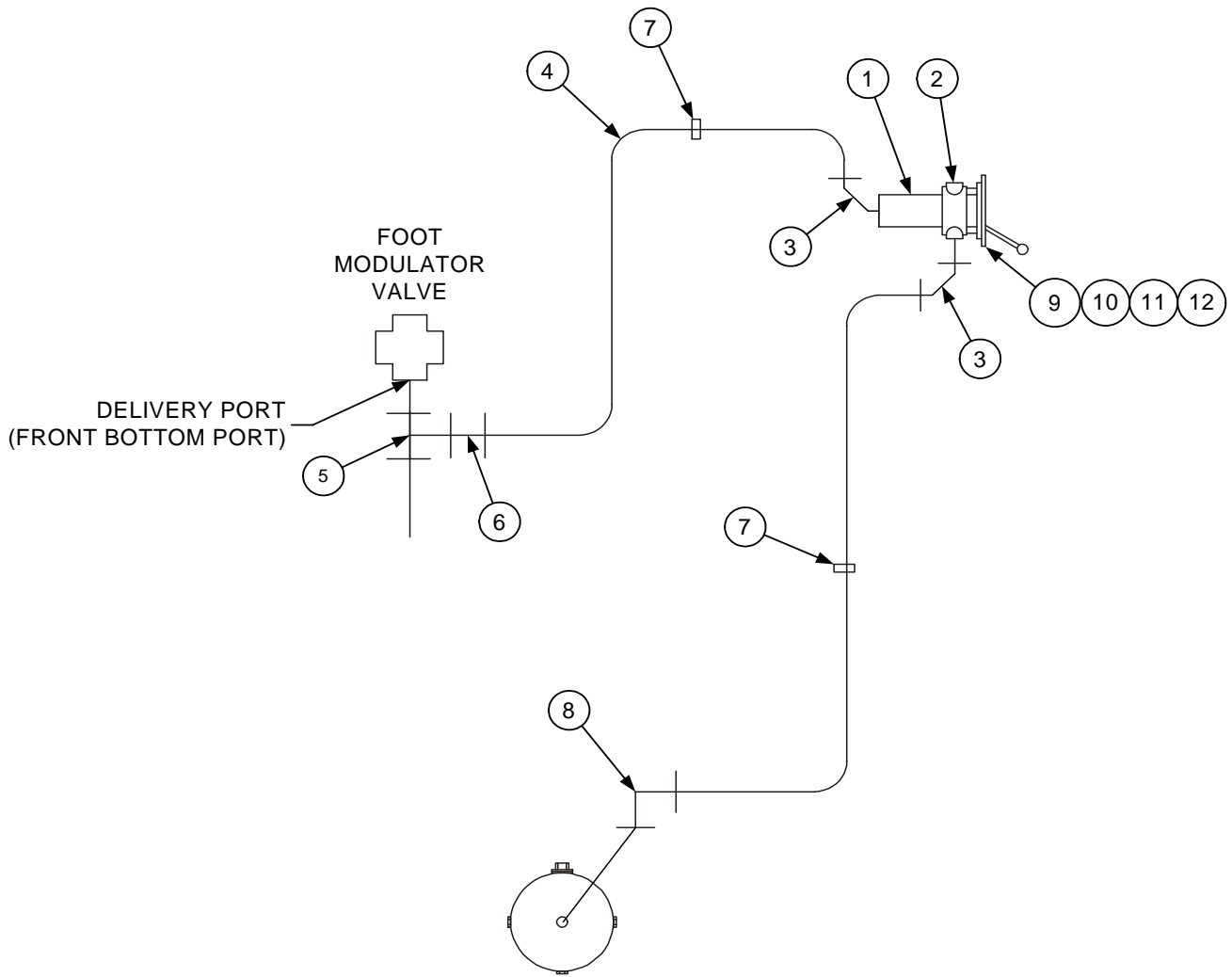

6

154057 Truck Brake Connection

ITEM	PART NO	DESCRIPTION	QTY
	154057	TRUCK BRAKE CONNECTION	1
1	F019332	Air Control Valve	1
2	F010989	Pipe Plug, 4 M NPT	1
3	F011117	45° Elbow, 6 x 4 M NPT	2
4	F018904	Hose Assembly	1
5	F013684	Tee, 6 F NPT x 6 M NPT x 6 F NPT	1
6	F012056	Adapter, 6 x 6 NPT	1
7	F012587	Grommet	2
8	F010988	90° Elbow, 6 x 4 M NPT	1
9	122583	Instruction Plate, Rail Wheel.....	1
10	F009591	Machine Screw, #10-24 x 3/4" Rd Hd	2
11	120457	Decal, Rail Brake Operation.....	1
12	120453	Bracket, Air Control Valve	1

154388 Truck Brake Connection

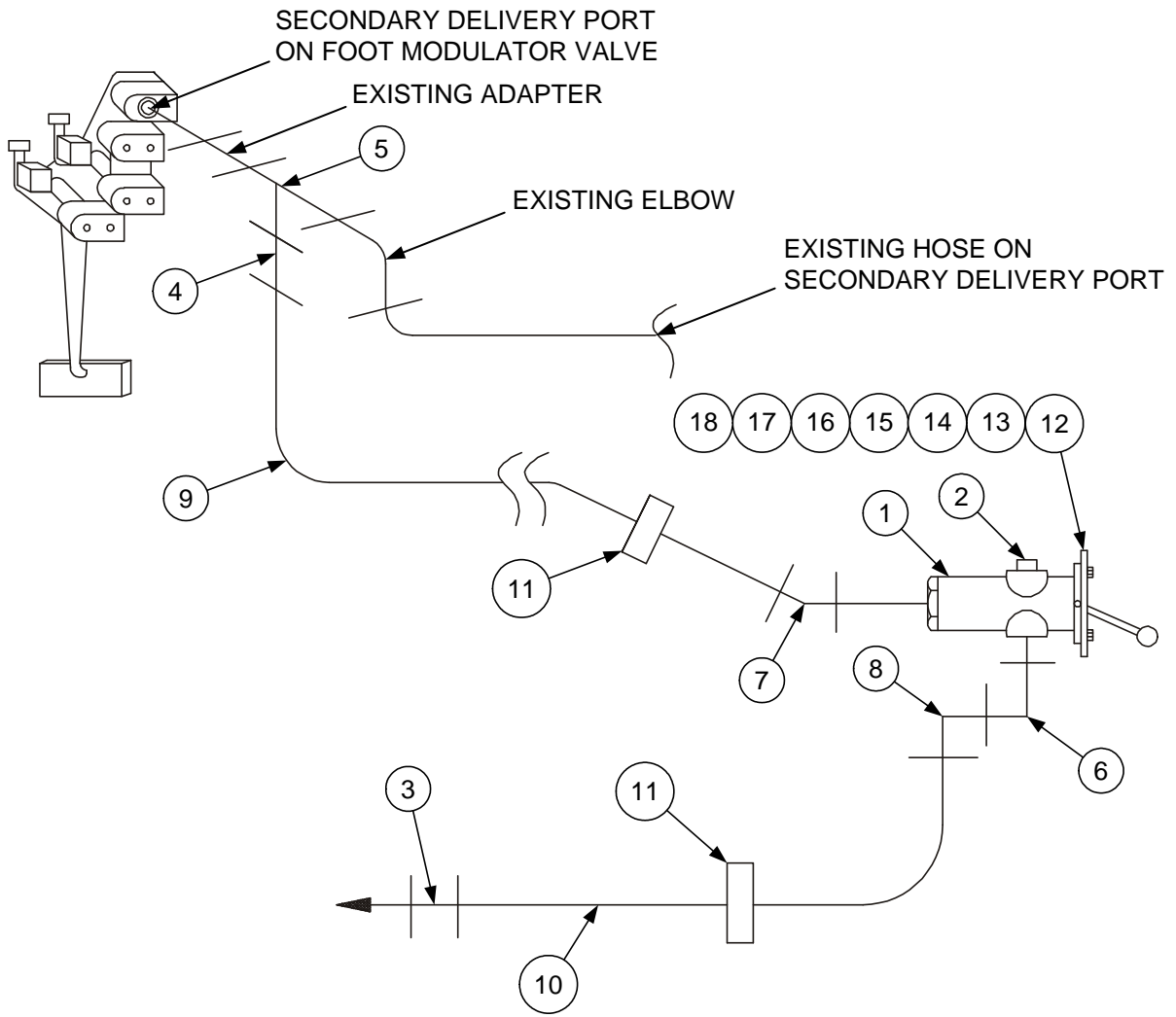

6

154388 Truck Brake Connection

ITEM	PART NO	DESCRIPTION	QTY
	154388	TRUCK BRAKE CONNECTION	1
1	F019332	Control Valve	1
2	F010989	Pipe Plug, 4 M NPT	1
3	F010994	Adapter, 6 x 4 M NPT	2
4	F012056	Adapter, 6 x 6 M NPT	1
5	F013684	Tee, 6 F NPT x 6 M NPT x 6 F NPT	1
6	F010988	90° Elbow, 6 x 4 M NPT	1
7	F011117	45° Elbow, 6 x 4 M NPT	1
8	F012808	90° Elbow, 6 x 6	1
9	F018904	Hose Assembly	1
10	160190	Hose Assembly	1
11	F012587	Grommet	2
12	122583	Instruction Plate - Rail Wheel Brakes ON/OFF	1
13	F009591	Machine Screw, #10-24 x 3/4" Rd Hd	2
14	120453	Bracket, Air Control Valve	1
15	F001113	Cap Screw, 5/16-18 x 1-1/4" Hex Hd	2
16	F001100	SAE Lock Washer, 5/16"	2
17	F007021	Hex Nut, 5/16"-18	2
18	120457	Decal, Rail Brake Operation	1

162114 Truck Brake Connection

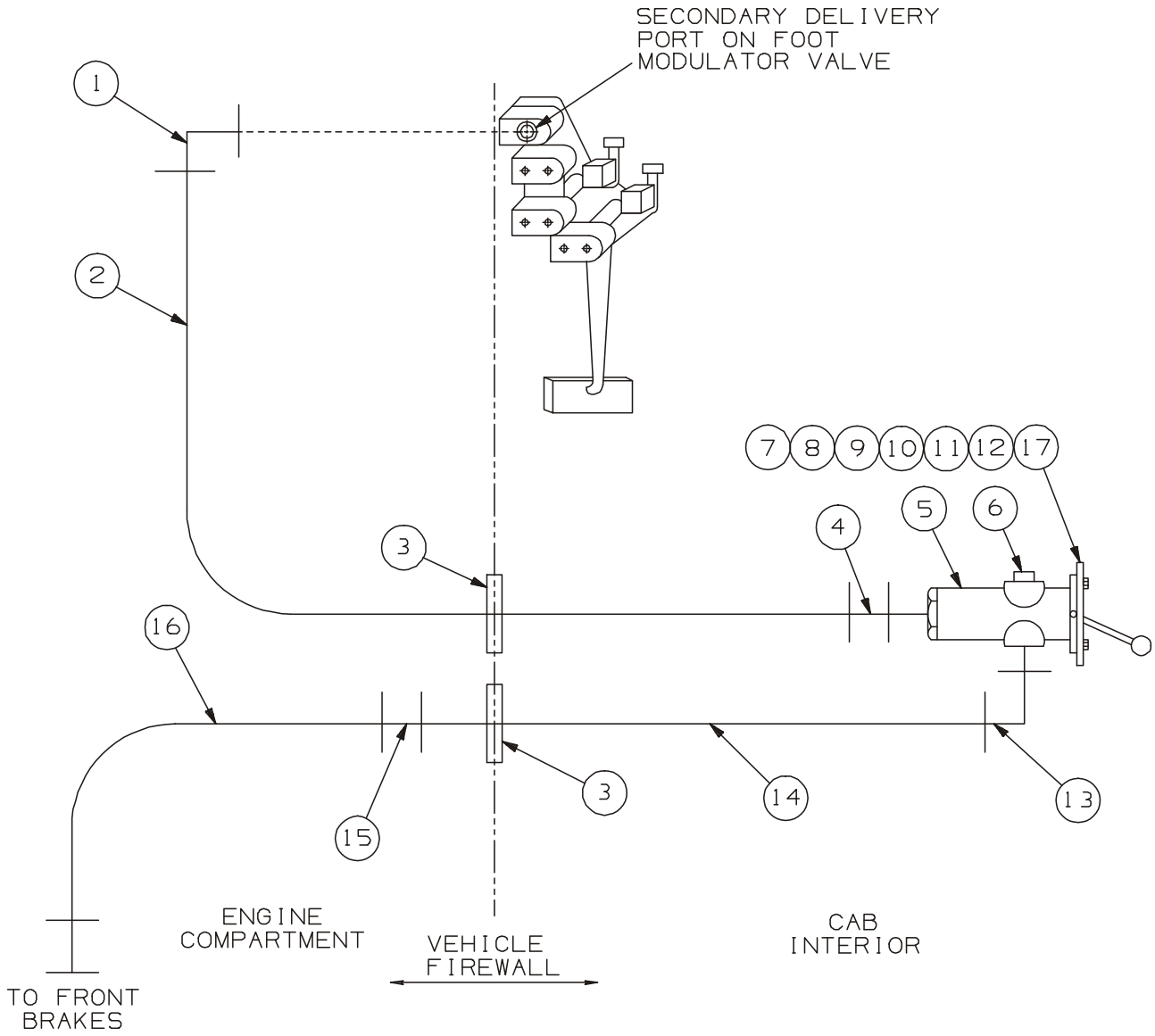

162114 Truck Brake Connection

ITEM	PART NO	DESCRIPTION	QTY
	162114	TRUCK BRAKE CONNECTION	1
1	F012055	90° Elbow, 6 x 6 M NPT.....	1
2	F018904	Hose Assembly	1
3	F012587	Grommet	2
4	F010994	Adapter, 6 x 4 M NPT	1
5	F019332	Air Control Valve	1
6	F010989	Pipe Plug, 4 M NPT	1
7	120453	Bracket.....	1
8	F001113	Cap Screw, 5/16-18 x 1-1/4" Hex Hd.....	2
9	F001100	SAE Lock Washer, 5/16"	2
10	F007021	Hex Nut, 5/16"-18	2
11	122583	Instruction Plate, Rail Wheel.....	1
12	F009591	Machine Screw, #10-24 x 3/4" Rd Hd	2
13	F010988	90° Elbow, 6 x 4 M NPT.....	1
14	079235	Hose Assembly	1
15	F011152	Adapter, 6 x 6.....	1
16	197914	Hose Assembly	1
17	120457	Decal, Rail Brake Operation (mount near control valve)	1
	F016578	Ty-Rap (use as needed)	5

162130 Truck Brake Connection

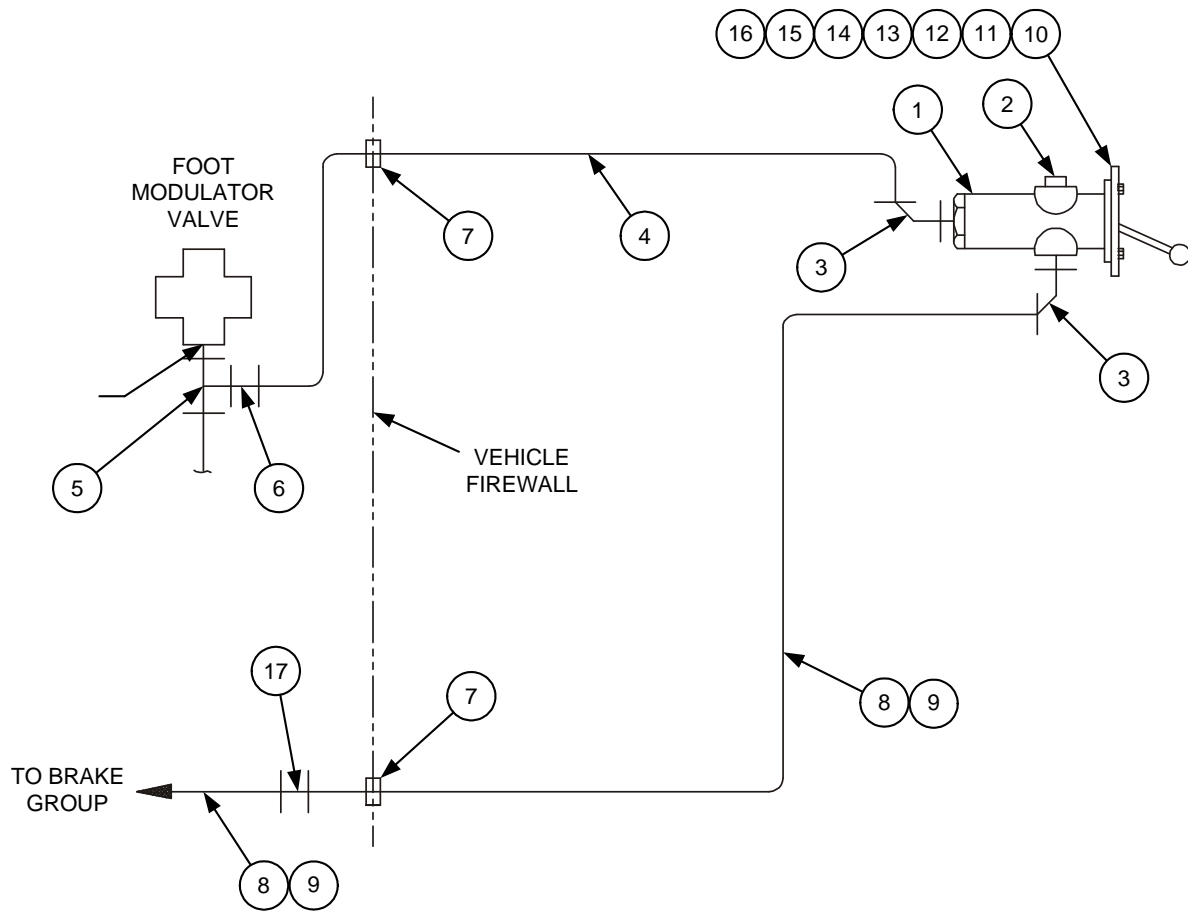

162130 Truck Brake Connection

ITEM	PART NO	DESCRIPTION	QTY
	162130	TRUCK BRAKE CONNECTION	1
1	F019332	Control Valve	1
2	F010989	Pipe Plug, 4 M NPT	1
3	F011117	45° Elbow, 6 x 4 M NPT	2
4	F018904	Hose Assembly	1
5	F013684	Tee, 6 F NPT x 6 NPT x 6 F NPT	1
6	F012056	Adapter, 6 x 6 NPT	1
7	F012587	Grommet	2
	154058	HOSE GROUP	1
8	F010693	Hose, 5/16" I.D.	180"
9	F011392	Swivel Hose Fitting	4
10	120453	Bracket (control valve mounting)	1
11	122583	Instruction Plate - Rail Wheel Brakes ON/OFF	1
12	F009591	Machine Screw, #10-24 x 3/4" Rd Hd	2
13	120457	Decal, Rail Brake Operation...	1
14	F001113	Cap Screw, 5/16-18 x 1-1/4" Hex Hd	2
15	F001100	SAE Lock Washer, 5/16"	2
16	F007021	Hex Nut, 5/16"-18	2
17	F011152	Adapter, 6 x 6	1

179161 Truck Brake Connection

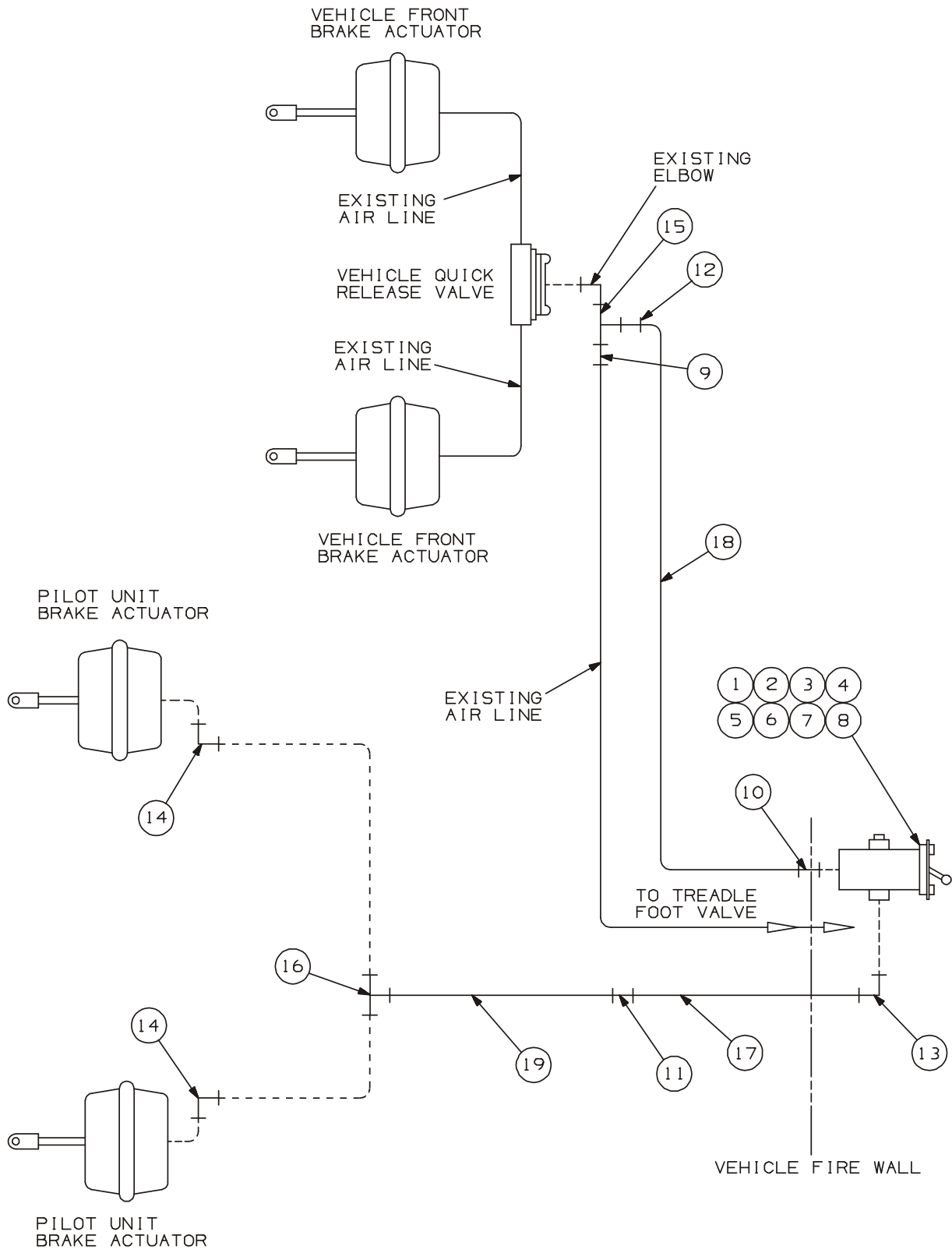

179161 Truck Brake Connection

ITEM	PART NO	DESCRIPTION	QTY
	179161	TRUCK BRAKE CONNECTION	1
1	F019332	Air Control Valve	1
2	120453	Sheet	1
3	F001113	Cap Screw, 5/16-18 x 1-1/4" Hex Hd	2
4	F001100	Lock Washer, 5/16"	2
5	F007021	Hex Nut, 5/16"-18 GR 5	2
6	122583	Instruction Plate	1
7	F009591	Machine Screw, #10-24 x 3/4" Rd Hd	2
8	F010989	Plug, 4 NPT Soc Hd.	1
9	F011604	Adapter, 6 NPT x 6 NPT	1
10	F010994	Adapter, 6 x 4 NPT	1
11	F011152	Adapter, 6 x 6	1
12	F012056	Adapter, 6 x 6 NPT	1
13	F010988	90° Elbow, 6 x 4 NPT	1
14	F012055	90° Elbow, 6 x 6 NPT	2
15	F013459	Tee, 6 FPT x 6 FPT x 6 FPT	1
16	F013627	Tee, 6 x 6 FS x 6	1
17	079235	Hose Assembly	1
18	160117	Hose Assembly	1
19	197914	Hose Assembly	1
20	120457	Decal, Rail Brake Operation (mount near control valve)	1
21	F016578	Ty-rap (use as needed)	5

137926 Hydraulic Power Pack - Full

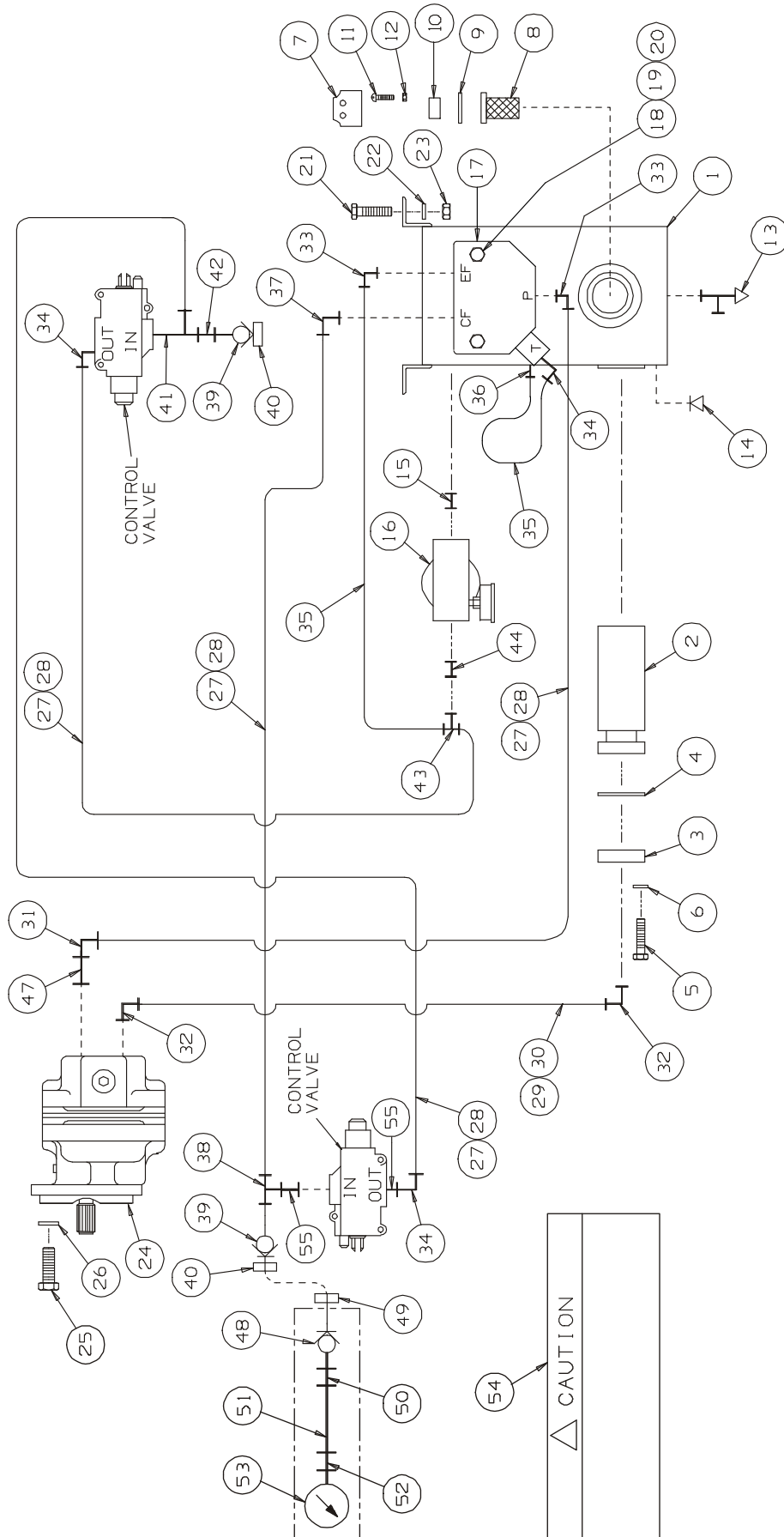

6

137926 Hydraulic Power Pack - Full

ITEM	PART NO	DESCRIPTION	QTY
	137926	HYDRAULIC POWER PACK -FULL	1
	129136	HYDRAULIC RESERVOIR ASSEMBLY	1
1	099444	Reservoir Only.	1
2	F014155	Filter	1
3	082205	Filter Flange	1
4	077997	Flange Gasket.	1
5	F001125	Cap Screw, 3/8-16 x 1-1/4" Hex Hd.	4
6	F001025	SAE Lock Washer, 3/8"	4
7	F022655	FILLER CAP	1
8	F010465	Filler Screen	1
9	056780	Filler Flange Gasket	2
10	F010466	Filler Flange.	1
11	F009723	Machine Screw, 10-24 x 3/8" Rd Hd	6
12	F009541	SAE Lock Washer, #10	6
13	F010181	Drain Valve, 1/8 M NPT	2
14	F012702	Pipe Plug, 3/8 M NPT Magnetic	1
15	F001328	Pipe Nipple, 3/4 M NPT x 1-3/8"	1
16	F015452	FILTER - RETURN	1
	F015453	Replacement Filter Element	1
17	120993	Valve, Flow Divider	1
18	F009663	Cap Screw, 5/16-18 x 2" Hex Hd.	2
19	F007021	Hex Nut, 5/16"-18	2
20	F001100	SAE Lock Washer, 5/16"	2
21	F001125	Cap Screw, 3/8-16 x 1-1/4" Hex Hd.	4
22	F001025	SAE Lock Washer, 3/8"	4
23	F007020	Hex Nut, 3/8"-16	4
24	F023330	Hydraulic Pump	1
25	F003136	Cap Screw, 1/2-13 x 1" Hex Hd.	2
26	F001075	SAE Lock Washer, 1/2"	2
	140344	HOSE GROUP	1
27	F009947	Hose, 13/32 x 960" (cut to length)	1
28	F020713	Hose Fitting, Swivel 3/4 F JIC (install on hose F009947)	8
29	F010298	Hose, 1-1/8 x 75" (cut to length)	1
30	F014307	Hose Fitting, Swivel 1-5/8 F JIC (install on hose F010298).	2
31	F013243	90° Elbow, 3/4 M NPT x 3/4 M JIC	1
32	F021260	90° Elbow, 1 M NPT x 1-5/8 M JIC	2
33	F012054	90° Elbow, 1/2 M NPT x 3/4 M JIC	2
34	F011114	90° Elbow, 3/8 M NPT x 3/4 M JIC	3
35	067736	Hose, 13/32 x 17" Swivel 3/4 F JIC Both Ends	2
36	F011170	Adapter, 3/8 M NPT x 3/4 M JIC	1
37	F012704	90° Elbow, 3/4 M JIC x 3/8 M NPT	1
38	F013605	Tee, 3/4 M JIC x 3/8 M NPT x 3/8 M NPT	1
39	F015303K	Nose Piece, 3/8 F NPT	2
40	F015077	Dust Cap	2

137926 Hydraulic Power Pack - Full

ITEM	PART NO	DESCRIPTION	QTY
41	F014722	Tee, 3/8 F NPT x 3/4 M JIC x 3/8 M NPT	1
42	F011604	Adapter, 3/8 M NPT x 3/8 M NPT	1
43	F013629	Tee, 3/4 M JIC x 3/4 M JIC x 3/8 M NPT	1
44	F012024	Reducer Bushing, 3/4 M NPT x 3/8 F NPT	1
45	Not Used		
47	F011617	Reducer Bushing, 1 M NPT x 3/4 F NPT	1
	099137K	PRESSURE GAUGE ASSEMBLY	1
48	F015110K	Body, 3/8 F NPT	1
49	F015111	Dust Cap	1
50	F012056	Adapter, 3/8 M NPT x 9/16 M JIC	1
51	171878	Hose, 3/8 x 14" Swivel 9/16 F JIC Both Ends	1
52	F011109	Adapter, 9/16 M JIC x 1/4 F NPT	1
53	F011432K	Pressure Gauge, 1/4 M NPT	1
54	137941	Decal, Caution -Recommended	1
55	F015103	Adapter, 3/8 F NPT x 3/4 M STR	2

137927 Hydraulic Power Pack - Abbreviated

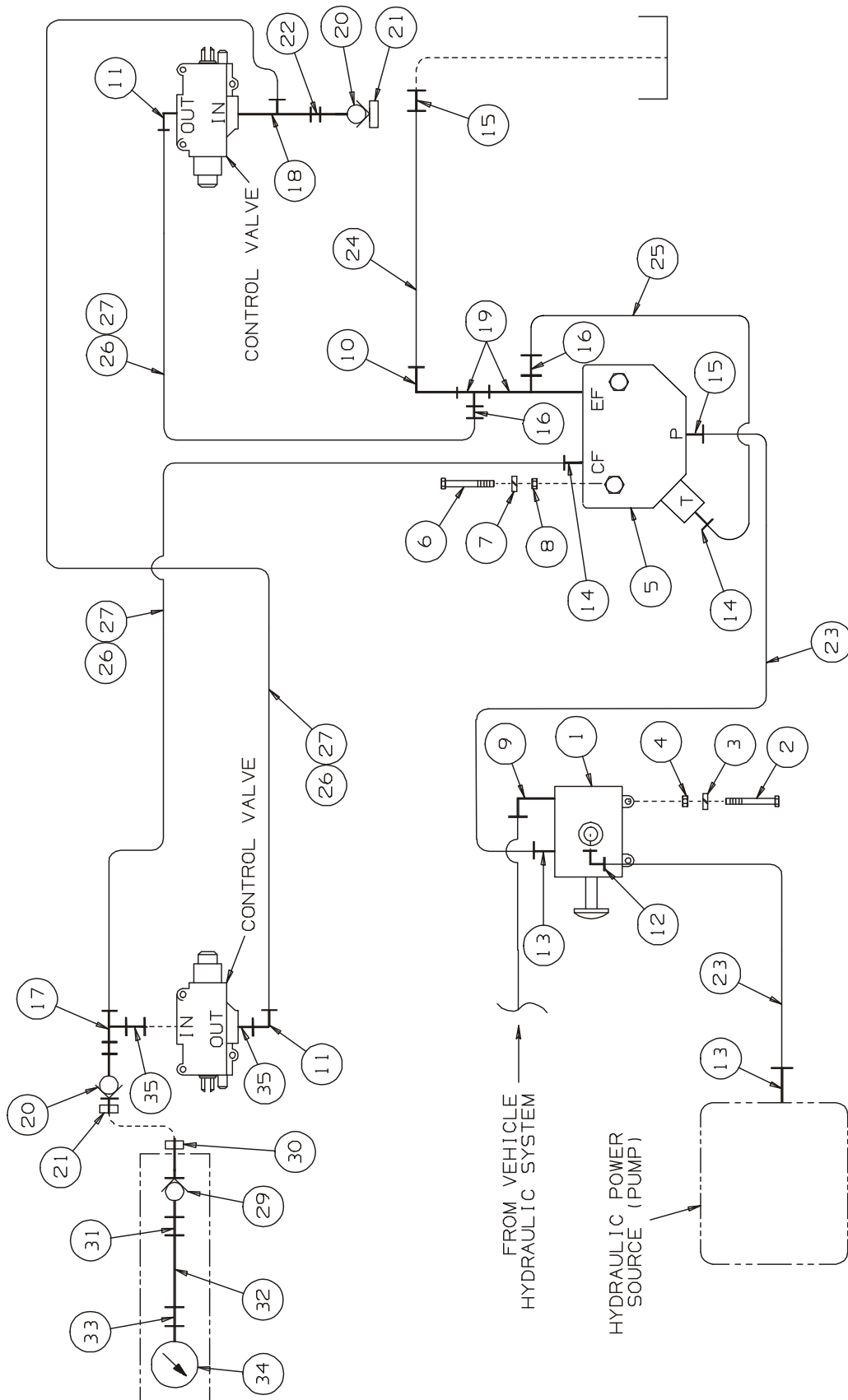

137927 Hydraulic Power Pack - Abbreviated

ITEM	PART NO	DESCRIPTION	QTY
	137927	HYDRAULIC POWER PACK -ABBREVIATED	1
1	F016490	Selector Valve	1
2	F002760	Cap Screw, 3/8-16 x 2-1/4" Hex Hd.	2
3	F001025	SAE Lock Washer, 3/8"	2
4	F009670	Hex Grip Nut, 3/8"-16	2
5	120993	Valve, Flow Divider	1
6	F009663	Cap Screw, 5/16-18 x 2" Hex Hd.	2
7	F001100	SAE Lock Washer, 5/16"	2
8	F007021	Hex Nut, 5/16"-18	2
9	F012010	90° Elbow Street, 3/4 F NPT x 3/4 M NPT	1
10	F010584	90° Elbow, 1-1/16 M JIC x 1/2 M NPT	1
11	F011114	90° Elbow, 3/4 M JIC x 3/8 M NPT	2
12	F010586	90° Elbow, 1-1/16 M JIC x 3/4 M NPT	1
13	F010581	Adapter, 1-1/16 M JIC x 3/4 M NPT	2
14	F011170	Adapter, 3/4 M JIC x 3/8 M NPT	2
15	F013210	Adapter, 1-1/16 M JIC x 1/2 M NPT	2
16	F012027	Adapter, 3/4 M JIC x 1/2 M NPT	2
17	F013605	Tee, 3/4 M JIC x 3/8 M NPT x 3/8 M NPT	1
18	F014722	Tee, 3/8 F NPT x 3/4 M JIC x 3/8 M NPT	1
19	F010692	Tee, 1/2 F NPT x 1/2 M NPT x 1/2 F NPT	2
20	F015303K	Nose Piece, 3/8 F NPT	2
21	F015077	Dust Cap	2
22	F011604	Adapter, 3/8 M NPT x 3/8 M NPT	1
23	071692	Hose, 5/16 x 48" Swivel 1-1/16 F JIC Both Ends.	2
24	111100	Hose, 3/4 x 28" Swivel 1-1/16 F JIC Both Ends.	1
25	071867	Hose, 1/2 x 19-3/4" Swivel 3/4 F JIC Both Ends	1
	140345	HOSE GROUP	1
26	F009947	Hose, 13/32 x 960" (cut to length)	1
27	F020713	Hose Fitting, Swivel 3/4 F JIC (install on hose F009947)	6
	099137K	PRESSURE GAUGE ASSEMBLY	1
29	F015110K	Body, 3/8 F NPT	1
30	F015111	Dust Cap	1
31	F012056	Adapter, 3/8 M NPT x 9/16 M JIC	1
32	171878	Hose, 3/8 x 14" Swivel 9/16 F JIC Both Ends	1
33	F011109	Adapter, 9/16 M JIC x 1/4 F NPT	1
34	F011432K	Pressure Gauge, 1/4 M NPT	1
35	F015103	Adapter, 3/8 F NPT x 3/4 M STR.	2

164574 Sight Rod Kit with Extension

PART NO	DESCRIPTION	QTY
164574	SIGHT ROD EXTENSION GROUP	1
130195	Sight Rod Kit (includes two sight rods)	1
135809	Sight Rod Extension	2
161855	Mounting Bar	2
F022036	Cap Screw, 1/2-13 x 1-1/4" Hex Flg Hd.	2
F022037	Hex Flg Nut, 1/2"-13	2

157310 Decal Service Group - Insulated Units

PART NO	DESCRIPTION	QTY
157310	DECAL SERVICE GROUP	1
F018082	Decal, Safety Instructions - Lock Front Wheels... ..	1
F018084	Decal, HY-RAIL® Operation	3
140220	Decal, Warning - Do Not Operate.... ..	3
155007	Decal, HY-RAIL® Vehicle Completed By... ..	1
157309	Decal, HY-RAIL® Operating Instructions.	1
BUL001256	HR4000 Series A2 Operator's Service and Parts Manual.	1
020851	Decal Application Drawing.	1

159438 Decal Service Group - Non-Insulated Units

PART NO	DESCRIPTION	QTY
159483	DECAL SERVICE GROUP	1
F018082	Decal, Safety Instructions - Lock Front Wheels... ..	1
F018084	Decal, HY-RAIL® Operation	3
140220	Decal, Warning - Do Not Operate.... ..	3
155007	Decal, HY-RAIL® Vehicle Completed By... ..	1
157309	Decal, HY-RAIL® Operating Instructions.	1
159457	Decal, Warning - Non-Insulated... ..	1
BUL001256	HR4000 Series A2 Operator's Service and Parts Manual.	1
021039	Decal Application Drawing.	1

SECTION 7 - VEHICLE APPLICATIONS
TABLE OF CONTENTS

Freightliner	5 - 2
International	5 - 7
Sterling	5 - 9

2005 FREIGHTLINER M2 106V 14,000 GAWR FRONT AXLE HR4000V FRONT HR4000A2 REAR 24" FRAME EXT.	2005 FREIGHTLINER M2 106V 14,000 GAWR FRONT AXLE HR4000V FRONT HR4000A2 REAR L FRAME EXT.
---	---

REQUIRED GROUPS

Top Level Group Number	203649	203771
Rear Guide Wheel Unit - Insulated With Side Shift	157712	157712
Rear Guide Wheel Unit - Non-Insulated With Side Shift	158145	158145
Rear Guide Wheel Unit - Insulated Without Side Shift	161282	161282
Rear Guide Wheel Unit - Non-Insulated Without Side Shift	162127	162127
Mounting Bracket Group	203648	203714
Steering Lock Group	203657	203657
Application Drawing - Rear	021465	021465

ACCESSORY GROUP OPTIONS

Hydraulic Power Pack - Full	137926	137926
Hydraulic Power Pack - Abbreviated	137927	137927
Rear Unit Brakes With Side Shift	158185	158185
Without Side Shift	161300	161300
Truck Brake Connection	162114	162114
* Rail Sweep Group - Rear	158663	158663
Hydraulic Lock Conversion Group	198747	198747
Sight Rod Kit with Extensions	164574	164574

* Recommended Safety Option

2005 FREIGHTLINER M2 106V 14,000 GAWR FRONT AXLE HR4000C2 FRONT HR4000A2 REAR L FRAME EXT.	2005 FREIGHTLINER M2 106V 14,000 GAWR FRONT AXLE HR4000C2 FRONT HR4000A2 REAR 24" FRAME EXT.
--	--

REQUIRED GROUPS

Top Level Group Number	203789	203790
Rear Guide Wheel Unit - Insulated With Side Shift	157712	157712
Rear Guide Wheel Unit - Non-Insulated With Side Shift	158145	158145
Rear Guide Wheel Unit - Insulated Without Side Shift	161282	161282
Rear Guide Wheel Unit - Non-Insulated Without Side Shift	162127	162127
Mounting Bracket Group	203782	203787
Rear Extension Group	203683	203683
Steering Lock Group	203657	203657
Application Drawing - Rear	021465	021465

ACCESSORY GROUP OPTIONS

Hydraulic Power Pack - Full	137926	137926
Hydraulic Power Pack - Abbreviated	137927	137927
Rear Unit Brakes With Side Shift	158185	158185
Without Side Shift	161300	161300
Truck Brake Connection	162114	162114
* Rail Sweep Group - Rear	158663	158663
Hydraulic Lock Conversion Group	198747	198747
Sight Rod Kit with Extensions	164574	164574

* Recommended Safety Option

2005 FREIGHTLINER M2 20,000 GAWR FRONT AXLE HR4500V1 FRONT HR4000A2 REAR L FRAME EXT.	2008 FREIGHTLINER M2 106V 14,000 GAWR FRONT AXLE HR4000V1 FRONT HR4000A2 REAR
---	--

REQUIRED GROUPS

Top Level Group Number	203602	3412543
Rear Guide Wheel Unit - Insulated With Side Shift	157712	157712
Rear Guide Wheel Unit - Non-Insulated With Side Shift	158145	158145
Rear Guide Wheel Unit - Insulated Without Side Shift	161282	161282
Rear Guide Wheel Unit - Non-Insulated Without Side Shift	162127	162127
Mounting Bracket Group	179139	3412066
Steering Lock Group	201234	201711
Application Drawing - Rear	024692	3412066

ACCESSORY GROUP OPTIONS

Hydraulic Power Pack - Full	137926	137926
Hydraulic Power Pack - Abbreviated	137927	137927
Rear Unit Brakes With Side Shift	158185	158185
Without Side Shift	161300	161300
Truck Brake Connection	179161	162114
* Rail Sweep Group - Rear	158663	158663
Hydraulic Lock Conversion Group	198747	198747
Sight Rod Kit with Extensions	164574	164574

* Recommended Safety Option

2008 FREIGHTLINER M2 106V 14,000 GAWR FRONT AXLE HR4500V1 FRONT HR4000A2 REAR	2008 FREIGHTLINER M2 112V HR4000V1 FRONT HR4000A2 REAR
--	---

REQUIRED GROUPS

Top Level Group Number	3412549	3412547
Rear Guide Wheel Unit - Insulated		
With Side Shift	157712	157712
Rear Guide Wheel Unit - Non-Insulated		
With Side Shift	158145	158145
Rear Guide Wheel Unit - Insulated		
Without Side Shift	161282	161282
Rear Guide Wheel Unit - Non-Insulated		
Without Side Shift	162127	162127
Mounting Bracket Group	3412066	3412066
Steering Lock Group	201711	201711
Application Drawing - Rear	3412066	3412066

ACCESSORY GROUP OPTIONS

Hydraulic Power Pack - Full	137926	137926
Hydraulic Power Pack - Abbreviated	137927	137927
Rear Unit Brakes		
With Side Shift	158185	158185
Without Side Shift	161300	161300
Truck Brake Connection	162114	162114
* Rail Sweep Group - Rear	158663	158663
Hydraulic Lock Conversion Group	198747	198747
Sight Rod Kit with Extensions	164574	164574

* Recommended Safety Option

2008 FREIGHTLINER M2 112V HR4500V1 FRONT HR4000A2 REAR	2009 FREIGHTLINER M2 112V 18,000-24,000 GAWR FRONT AXLE HR4000V1 FRONT HR4000A2 REAR
---	---

REQUIRED GROUPS

Top Level Group Number	3413203	3416864
Rear Guide Wheel Unit - Insulated		
With Side Shift	157712	157712
Rear Guide Wheel Unit - Non-Insulated		
With Side Shift	158145	158145
Rear Guide Wheel Unit - Insulated		
Without Side Shift	161282	161282
Rear Guide Wheel Unit - Non-Insulated		
Without Side Shift	162127	162127
Mounting Bracket Group	3412066	3412066
Steering Lock Group	201711	201711
Application Drawing - Rear	3412066	3412066

ACCESSORY GROUP OPTIONS

Hydraulic Power Pack - Full	137926	137926
Hydraulic Power Pack - Abbreviated	137927	137927
Rear Unit Brakes		
With Side Shift	158185	158185
Without Side Shift	161300	161300
Truck Brake Connection	162114	162114
* Rail Sweep Group - Rear	158663	158663
Hydraulic Lock Conversion Group	198747	198747
Sight Rod Kit with Extensions	164574	164574

* Recommended Safety Option

2008 INTERNATIONAL SERIES 7500 SBA 16,000 GAWR FRONT AXLE HR4000V1 FRONT HR4000A2 REAR	2008 INTERNATIONAL SERIES 7600 HR4500V1 FRONT HR4000A2 REAR
---	--

REQUIRED GROUPS

Top Level Group Number	3412018	3412549
Rear Guide Wheel Unit - Insulated		
With Side Shift	157712	157712
Rear Guide Wheel Unit - Non-Insulated		
With Side Shift	158145	158145
Rear Guide Wheel Unit - Insulated		
Without Side Shift	161282	161282
Rear Guide Wheel Unit - Non-Insulated		
Without Side Shift	162127	162127
Mounting Bracket Group	3412066	3412066
Steering Lock Group	201711	201711
Application Drawing - Rear	3412066	3412066

ACCESSORY GROUP OPTIONS

Hydraulic Power Pack - Full	137926	137926
Hydraulic Power Pack - Abbreviated	137927	137927
Rear Unit Brakes		
With Side Shift	158185	158185
Without Side Shift	161300	161300
Truck Brake Connection	162114	162114
* Rail Sweep Group - Rear	158663	158663
Hydraulic Lock Conversion Group	198747	198747
Sight Rod Kit with Extensions	164574	164574

* Recommended Safety Option

2009 INTERNATIONAL SERIES 7400 SBA 14,000 GAWR FRONT AXLE HR4000V1 FRONT HR4000A2 REAR	2008 INTERNATIONAL SERIES 4900 12,000 GAWR FRONT AXLE HR3000V1 FRONT HR4000A2 REAR
---	---

REQUIRED GROUPS

Top Level Group Number	3415748	3421406
Rear Guide Wheel Unit - Insulated		
With Side Shift	157712	157712
Rear Guide Wheel Unit - Non-Insulated		
With Side Shift	158145	158145
Rear Guide Wheel Unit - Insulated		
Without Side Shift	161282	161282
Rear Guide Wheel Unit - Non-Insulated		
Without Side Shift	162127	162127
Mounting Bracket Group	3412066	3412066
Steering Lock Group	201711	201711
Application Drawing - Rear	3412066	3412066

ACCESSORY GROUP OPTIONS

Hydraulic Power Pack - Full	137926	137926
Hydraulic Power Pack - Abbreviated	137927	137927
Rear Unit Brakes		
With Side Shift	158185	158185
Without Side Shift	161300	161300
Truck Brake Connection	162114	162114
* Rail Sweep Group - Rear	158663	158663
Hydraulic Lock Conversion Group	198747	198747
Sight Rod Kit with Extensions	164574	164574

* Recommended Safety Option

2010 INTERNATIONAL
SERIES 7400
HR4000V1 FRONT
HR4000A2 REAR

2006 STERLING
LT9513
20,000 GAWR
FRONT AXLE
HR4000C2 FRONT
HR4000A2 REAR

REQUIRED GROUPS

Top Level Group Number	3427753	3410576
Rear Guide Wheel Unit - Insulated		
With Side Shift	157712	157712
Rear Guide Wheel Unit - Non-Insulated		
With Side Shift	158145	158145
Rear Guide Wheel Unit - Insulated		
Without Side Shift	161282	161282
Rear Guide Wheel Unit - Non-Insulated		
Without Side Shift	162127	162127
Mounting Bracket Group	3412066	3412066
Steering Lock Group	201711	201711
Application Drawing - Rear	3412066	3412066

ACCESSORY GROUP OPTIONS

Hydraulic Power Pack - Full	137926	137926
Hydraulic Power Pack - Abbreviated	137927	137927
Rear Unit Brakes		
With Side Shift	158185	158185
Without Side Shift	161300	161300
Truck Brake Connection	162114	179161
* Rail Sweep Group - Rear	158663	158663
Sight Rod Kit with Extensions	164574	164574

* Recommended Safety Option

2009 STERLING LT9500 HR4000V1 FRONT HR4000A2 REAR	2009 STERLING LT9500 HR4500V1 FRONT HR4000A2 REAR
--	--

REQUIRED GROUPS

Top Level Group Number	3418157	3420532
Rear Guide Wheel Unit - Insulated		
With Side Shift	157712	157712
Rear Guide Wheel Unit - Non-Insulated		
With Side Shift	158145	158145
Rear Guide Wheel Unit - Insulated		
Without Side Shift	161282	161282
Rear Guide Wheel Unit - Non-Insulated		
Without Side Shift	162127	162127
Mounting Bracket Group	3412066	3412066
Steering Lock Group	201711	201711
Application Drawing - Rear	3412066	3412066

ACCESSORY GROUP OPTIONS

Hydraulic Power Pack - Full	137926	137926
Hydraulic Power Pack - Abbreviated	137927	137927
Rear Unit Brakes		
With Side Shift	158185	158185
Without Side Shift	161300	161300
Truck Brake Connection	162114	162114
* Rail Sweep Group - Rear	158663	158663
Hydraulic Lock Conversion Group	198747	198747
Sight Rod Kit with Extensions	164574	164574

* Recommended Safety Option

APPENDIX A - TORQUE SPECIFICATIONS AND CONVERSION TABLES
TABLE OF CONTENTS

Bolt Torque Requirements - Standard Type Fasteners	A - 2
Bolt Torque Requirements - Serrated Type Flange Fasteners	A - 3
Bolt Torque Requirements - Metric Type Fasteners	A - 4
Recommended Hydraulic Fitting Assembly Torque	A - 6
Inch To Millimeters	A - 7
Feet To Meters	A - 7
Pounds To Kilograms	A - 8
Pounds Per Square Inch To Bar	A - 8
Pounds Per Square Inch To Kilopascals	A - 8
Fahrenheit To Celsius (Centigrade)	A - 9
Miles Per Hour To Kilometers Per Hour	A - 10
Gallons To Liters	A - 10



Appendix A

**STANDARD BOLT TORQUE REQUIREMENTS TABLE
STANDARD TYPE FASTENERS**

The torque values listed below are for standard-type fasteners only. The torque values listed are based on wet and (lubricated) dry conditions. The torque values for 1/4 and 5/16 inch size fasteners are listed in lb-in and N-m torque equivalents. The torque values for all other size fasteners are listed lb-ft and N-m torque equivalents. Use lower grade torque values if bolt and nut have different SAE grades. Manufacturer's SAE grade markings may vary.

STANDARD MARKINGS AND TORQUE SPECIFICATIONS

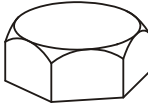
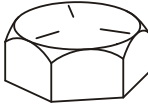
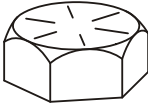
SAE Grade	1 or 2				5				8			
Fastener Standard SAE Grade Markings												
Fastener Body Size Inch-Thread	Torque				Torque				Torque			
	Wet		Dry		Wet		Dry		Wet		Dry	
	lb-in	N-m	lb-in	N-m	lb-in	N-m	lb-in	N-m	lb-in	N-m	lb-in	N-m
1/4 - 20	49	5.5	65	7.3	75	8.5	100	11.3	107	12.0	142	16.0
1/4 - 28	56	6.5	74	8.3	86	9.7	114	12.8	122	13.8	162	18.3
5/16 - 18	103	11.6	137	15.5	157	17.7	208	23.5	220	24.8	293	33.1
5/16 - 24	113	12.7	150	16.9	173	19.5	230	25.9	244	27.5	325	36.7
Fastener Body Size Inch-Thread	Torque				Torque				Torque			
	Wet		Dry		Wet		Dry		Wet		Dry	
	lb-ft	N-m	lb-ft	N-m	lb-ft	N-m	lb-ft	N-m	lb-ft	N-m	lb-ft	N-m
3/8 - 16	15	20	20	27	23	31	31	42	32	43	43	58
3/8 - 24	17	23	23	31	26	35	35	47	37	50	49	66
7/16 - 14	24	32	32	43	37	50	49	66	52	70	69	93
7/16 - 20	27	36	36	49	42	57	56	76	58	78	77	104
1/2 - 13	39	53	52	70	57	77	76	103	80	108	106	144
1/2 - 20	41	55	55	74	64	87	85	115	90	122	120	163
9/16 - 12	53	72	71	96	82	111	109	148	115	156	153	207
9/16 - 18	59	80	78	106	91	123	121	164	129	175	172	233
5/8 - 11	73	99	97	131	113	155	150	203	160	217	213	289
5/8 - 18	83	112	110	149	128	173	170	230	180	244	239	324
3/4 - 10	129	175	172	233	200	271	266	361	282	382	375	508
3/4 - 16	144	195	192	260	223	302	297	403	315	427	419	568
7/8 - 9	124	168	165	224	323	438	430	583	454	615	604	819
7/8 - 14	138	187	184	249	355	481	472	640	501	679	666	903
1 - 8	188	255	250	339	483	655	642	870	681	923	906	1228
1 - 14	210	285	279	378	541	733	720	976	764	1036	1016	1377
1-1/8 - 7	266	361	354	480	596	808	793	1075	966	1310	1285	1742
1-1/8 - 12	297	403	395	535	668	906	888	1204	1083	1468	1440	1952
1-1/4 - 7	375	508	499	676	841	1140	1119	1517	1363	1848	1813	2458
1-1/4 - 12	415	563	552	748	930	1261	1237	1677	1509	2046	2007	2721
1-3/8 - 6	492	667	654	887	1102	1494	1466	1988	1787	2423	2377	3223
1-3/8 - 12	560	759	745	1010	1255	1701	1670	2264	2034	2758	2705	3667
1-1/2 - 6	653	885	868	1177	1463	1983	1946	2638	2371	3215	3153	4275
1-1/2 - 12	734	995	976	1323	1645	2230	2188	2966	2668	3617	3548	4810



A

Appendix A

**STANDARD BOLT TORQUE REQUIREMENTS TABLE
SERRATED TYPE FLANGE FASTENERS**

The torque values listed below are for serrated-type flange fasteners only. The torque values listed are based on wet (lubricated) and dry conditions. The torque values for all other size fasteners are listed in lb-ft and N-m torque equivalents. Use lower grade torque values if bolt and nut have different SAE grades. Manufacturer's SAE grade markings may vary.

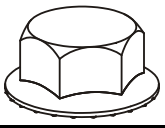
STANDARD MARKINGS AND TORQUE SPECIFICATIONS

SAE Grade	1 or 2				5			
Fastener Standard SAE Grade Markings								
Fastener Body Size Inch-Thread	Torque				Torque			
	Wet		Dry		Wet		Dry	
	lb-ft	N-m	lb-ft	N-m	lb-ft	N-m	lb-ft	N-m
1/4 - 20	8	10.8	11	14.9	11	14.9	15	20.3
1/4 - 28	9	12.2	12	16.3	12	16.3	16	21.7
5/16 - 18	13	17.6	17	23.0	20	27.1	27	36.6
5/16 - 24	13	17.6	17	23.0	32	43.3	43	58.3
3/8 - 16	23	31	31	42	40	54	53	72
3/8 - 24	25	34	33	45	43	58	57	77
7/16 - 14	38	51	51	69	55	74	73	99
7/16 - 20	40	54	53	72	60	81	80	108
1/2 - 13	60	81	80	108	95	129	127	172
1/2 - 20	65	88	87	118	100	135	133	180
9/16 - 12	78	106	104	141	140	190	187	253
9/16 - 18	85	115	113	153	150	203	200	271
5/8 - 11	125	169	167	226	190	258	253	343
5/8 - 18	135	183	180	244	220	298	293	397
3/4 - 10	225	305	300	407	350	474	467	633
3/4 - 16	250	339	333	451	400	542	533	723
7/8 - 9	350	474	467	633	550	746	733	994
7/8 - 14	375	508	500	678	600	813	800	1085
1 - 8	480	651	640	868	750	1017	1000	1356
1 - 14	500	678	666	903	800	1085	1066	1445









A

Appendix A

**BOLT TORQUE REQUIREMENTS TABLE
METRIC TYPE FASTENERS**

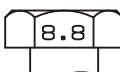
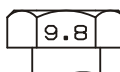
Do not use these values if a different torque value or tightening procedure is given for a specific application. Torque values listed are for general use only. Check tightness of fasteners periodically. Fasteners should be replaced with the same or higher property class. If higher property class fasteners are used, these should only be tightened to the strength of the original. Make sure fastener's threads are clean and that thread engagement is properly started. This will help prevent them from failing when tightening.

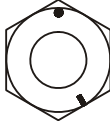
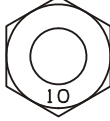
* Lubricated means coated with a lubricant such as engine oil, or fasteners with phosphate and oil coatings. Dry means plain or zinc plated without any lubrication.

Property Class and Head Markings	4.8				8.8		9.8	
								
Property Class and Head Markings	5			10				
								
Size	Class 4.8				Class 8.8 or 9.8			
	* Lubricated		* Dry		* Lubricated		* Dry	
	N - m	lb - ft	N - m	lb - ft	N - m	lb - ft	N - m	lb - ft
M 6	4.8	3.5	6	4.5	9	6.5	11	8.5
M 8	12	8.5	15	11	22	16	28	20
M10	23	17	29	21	43	32	55	40
M12	40	29	50	37	75	55	95	70
M14	63	47	80	60	120	88	150	110
M16	100	73	125	92	190	140	240	175
M18	135	100	175	125	260	195	330	250
M20	190	140	240	180	375	275	475	350
M22	260	190	330	250	510	375	650	475
M24	330	250	425	310	650	475	825	600
M27	490	360	625	450	950	700	1200	875
M30	675	490	850	625	1300	950	1650	1200
M33	900	675	1150	850	1750	1300	2200	1650
M36	1150	850	1450	1075	2250	1650	2850	2100

A

Appendix A

**BOLT TORQUE REQUIREMENTS TABLE
METRIC TYPE FASTENERS**

Do not use these values if a different torque value or tightening procedure is given for a specific application. Torque values listed are for general use only. Check tightness of fasteners periodically. Fasteners should be replaced with the same or higher property class. If higher property class fasteners are used, these should only be tightened to the strength of the original. Make sure fastener's threads are clean and that thread engagement is properly started. This will help prevent them from failing when tightening.

* Lubricated means coated with a lubricant such as engine oil, or fasteners with phosphate and oil coatings. Dry means plain or zinc plated without any lubrication.

Property Class and Head Markings	10.9				12.9			
Property Class and Head Markings	10				12			
Size	Class 10.9				Class 12.9			
	* Lubricated		* Dry		* Lubricated		* Dry	
	N - m	lb - ft	N - m	lb - ft	N - m	lb - ft	N - m	lb - ft
M 6	13	9.5	17	12	15	11.5	19	14.5
M 8	32	24	40	30	37	28	47	35
M10	63	47	80	60	75	55	95	70
M12	110	80	140	105	130	95	165	120
M14	175	130	225	165	205	150	260	190
M16	275	200	350	255	320	240	400	300
M18	375	275	475	350	440	325	560	410
M20	530	400	675	500	625	460	800	580
M22	725	540	925	675	850	625	1075	800
M24	925	675	1150	850	1075	800	1350	1000
M27	1350	1000	1700	1250	1600	1150	2000	1500
M30	1850	1350	2300	1700	2150	1600	2700	2000
M33	2500	1850	3150	2350	2900	2150	3700	2750
M36	3200	2350	4050	3000	3750	2750	4750	3500

A

Appendix A

RECOMMENDED HYDRAULIC FITTING ASSEMBLY TORQUE

Straight Thread O-Ring Boss Low Pressure with 37° (SAEJ514)				Straight Thread O-Ring Boss High Pressure with O-Ring Seal (ORS) (J1453)			
Dash Size	Thread Size (inches)	Jam Nut or Straight Fitting Torque		Dash Size	Thread Size (inches)	Jam Nut or Straight Fitting Torque	
		lb-ft	N-m			lb-ft	N-m
-03	3/8-24	8-9	12-13	-03	3/8-24	8-10	11-13
-04	7/16-20	13-15	18-20	-04	7/16-20	14-16	20-22
-05	1/2-20	14-15	19-21	-05	1/2-20	18-20	24-27
-06	9/16-18	23-24	32-33	-06	9/16-18	24-26	33-35
-08	3/4-16	40-43	55-57	-08	3/4-16	50-60	68-78
-10	7/8-14	43-48	59-64	-10	7/8-14	72-80	98-110
-12	1-1/16-12	68-75	93-101	-12	1-1/16-12	125-135	170-183
-14	1-3/16-12	83-90	113-122	-14	1-3/16-12	160-180	215-245
-16	1-5/16-12	112-123	152-166	-16	1-5/16-12	200-220	270-300
-20	1-5/8-12	146-161	198-218	-20	1-5/8-12	210-280	285-380
-24	1-7/8-12	154-170	209-230	-24	1-7/8-12	270-360	370-490
-32	2-1/2-12	218-240	296-325				

O-Ring Seal (ORS)				SAE 37° (JIC)			
Dash Size	Thread Size (inches)	Swivel Nut		Dash Size	Thread Size (inches)	Swivel Nut	
		lb-ft	N-m			lb-ft	N-m
-04	9/16-18	10-12	14-16	-04	7/16-20	11-12	15-16
-06	11/16-16	18-20	24-27	-05	1/2-20	15-16	20-22
-08	13/16-16	32-35	43-47	-06	9/16-18	18-20	24-28
-10	1-14	46-50	62-68	-08	3/4-16	38-42	52-58
-12	1-3/16-12	65-70	88-95	-10	7/8-14	57-62	77-85
-16	1-7/16-12	92-100	125-136	-12	1-1/16-12	79-87	108-119
-20	1-11/16-12	125-140	170-190	-16	1-5/16-12	108-113	148-154
-24	2-12	150-165	204-224	-20	1-5/8-12	127-133	173-182
				-24	1-7/8-12	158-167	216-227
				-32	2-1/2-12	245-258	334-352

Metric			British Standard Pipe Parallel (BSPP)		
Thread Size	Straight Adapter or Locknut Torque		Thread Size	Straight Adapter or Locknut Torque	
mm	lb-ft	N-m	Inches **	lb-ft	N-m
M10 x 1	13-15	18-20	G 1/8-28	13-15	18-20
M12 x 1.5	15-19	20-25	G 1/4-19	19-23	25-30
M14 x 1.5	19-23	25-30	G 3/8-19	33-40	45-55
M16 x 1.5	33-40	45-55	G 1/2-14	55-70	75-95
M18 x 1.5	37-44	50-60	G 3/4-14	103-118	140-160
M20 x 1.5	52-66	70-90	G 1-11	162-184	220-250
M22 x 1.5	55-70	75-95	G 1-1/4-11	170-192	230-260
M26 x 1.5	81-96	110-130	G 1-1/2-11	258-347	350-470
M27 x 2	96-111	130-150			
M33 x 2	162-184	220-250			
M42 x 2	170-192	230-260			
M48 x 2	258-347	350-470			

** "G" denotes parallel threads, other than ISO 6149 (Port connection only)

A

Appendix A

INCH TO MILLIMETER CONVERSION TABLE
1 INCH = 25.4 MILLIMETERS

FRACTIONS	DECIMALS	MILLIMETERS	FRACTIONS	DECIMALS	MILLIMETERS
1/64	.016	0.397	33/64	.516	13.097
1/32	.031	0.794	17/32	.531	13.494
3/64	.047	1.191	35/64	.547	13.891
1/16	.063	1.588	9/16	.563	14.288
5/64	.078	1.984	37/64	.578	14.684
3/32	.094	2.381	19/32	.594	15.081
7/64	.109	2.778	39/64	.609	15.478
1/8	.125	3.175	5/8	.625	15.875
9/64	.141	3.572	41/64	.641	16.272
5/32	.156	3.969	21/32	.656	16.669
11/64	.172	4.366	43/64	.672	17.066
3/16	.188	4.763	11/16	.688	17.463
13/64	.203	5.159	45/64	.703	17.859
7/32	.219	5.556	23/32	.719	18.256
15/64	.234	5.953	47/64	.734	18.653
1/4	.250	6.350	3/4	.750	19.050
17/64	.266	6.747	49/64	.766	19.447
9/32	.281	7.144	25/32	.781	19.844
19/64	.297	7.541	51/64	.797	20.241
5/16	.313	7.938	13/16	.813	20.638
21/64	.328	8.334	53/64	.828	21.034
11/32	.344	8.731	27/32	.844	21.431
23/64	.359	9.128	55/64	.859	21.828
3/8	.375	9.525	7/8	.875	22.225
25/64	.391	9.922	57/64	.891	22.622
13/32	.406	10.319	29/32	.906	23.019
27/64	.422	10.716	59/64	.922	23.416
7/16	.438	11.113	15/16	.938	23.813
29/64	.453	11.509	61/64	.953	24.209
15/32	.469	11.906	31/32	.969	24.606
31/64	.484	12.303	63/64	.984	25.003
1/2	.500	12.700	1	1.000	25.400

FEET TO METERS CONVERSION TABLE
1 FOOT = 0.3048 METER

FEET	METERS	FEET	METERS	FEET	METERS	FEET	METERS	FEET	METERS
100	30.480	10	3.048	1	0.305	0.1	0.030	0.01	0.003
200	60.960	20	6.096	2	0.610	0.2	0.061	0.02	0.006
300	91.440	30	9.144	3	0.914	0.3	0.091	0.03	0.009
400	121.920	40	12.192	4	1.219	0.4	0.122	0.04	0.012
500	152.400	50	15.240	5	1.524	0.5	0.152	0.05	0.015
600	182.880	60	18.288	6	1.829	0.6	0.183	0.06	0.018
700	213.360	70	21.336	7	2.134	0.7	0.213	0.07	0.021
800	243.840	80	24.384	8	2.438	0.8	0.244	0.08	0.024
900	274.320	90	27.432	9	2.743	0.9	0.274	0.09	0.027
1,000	304.800	100	30.480	10	3.048	1.0	0.305	0.10	0.030

A

Appendix A

POUNDS TO KILOGRAMS CONVERSION TABLE
1 POUND = 0.4536 KILOGRAM

LB	KG	LB	KG	LB	KG	LB	KG	LB	KG
1,000	453.59	100	45.36	10	4.54	1	0.45	0.1	0.05
2,000	907.18	200	90.72	20	9.07	2	0.91	0.2	0.09
3,000	1,360.78	300	136.08	30	13.61	3	1.36	0.3	0.14
4,000	1,814.37	400	181.44	40	18.14	4	1.81	0.4	0.18
5,000	2,267.96	500	226.80	50	22.68	5	2.27	0.5	0.23
6,000	2,721.55	600	272.16	60	27.22	6	2.72	0.6	0.27
7,000	3,175.15	700	317.51	70	31.75	7	3.18	0.7	0.32
8,000	3,628.74	800	362.87	80	36.29	8	3.63	0.8	0.36
9,000	4,082.33	900	408.23	90	40.82	9	4.08	0.9	0.41
10,000	4,535.92	1,000	453.59	100	45.36	10	4.54	1.0	0.45

POUNDS PER SQUARE INCH TO BAR CONVERSION TABLE
1 PSI = 0.06895 BAR

PSI	BAR	PSI	BAR	PSI	BAR	PSI	BAR
1,000	68.95	100	6.90	10	0.69	1	0.07
2,000	137.90	200	13.79	20	1.38	2	0.14
3,000	206.84	300	20.68	30	2.07	3	0.21
4,000	275.80	400	27.58	40	2.76	4	0.28
5,000	344.70	500	34.47	50	3.45	5	0.35
6,000	413.64	600	41.36	60	4.14	6	0.41
7,000	482.58	700	48.26	70	4.83	7	0.48
8,000	551.52	800	55.15	80	5.52	8	0.55
9,000	620.46	900	62.05	90	6.21	9	0.62
10,000	689.48	1,000	68.95	100	6.90	10	0.69

POUNDS PER SQUARE INCH TO KILOPASCALS CONVERSION TABLE
1 PSI = 6.895 kPa

PSI	kPa	PSI	kPa
10	68.95	1	6.90
20	137.90	2	13.79
30	206.84	3	20.68
40	275.80	4	27.58
50	344.70	5	34.47
60	413.64	6	41.36
70	482.58	7	48.26
80	551.52	8	55.15
90	620.46	9	62.05
100	689.48	10	68.95

A

Appendix A

FAHRENHEIT TO CELSIUS (Centigrade) CONVERSION TABLE
(DEGREES F - 32°) ÷ 1.8 = DEGREES C

deg F	deg C	deg F	deg C	deg F	deg C	deg F	deg C
1	-17.2	51	10.6	101	38.3	151	66.1
2	-16.7	52	11.1	102	38.9	152	66.7
3	-16.1	53	11.7	103	39.4	153	67.2
4	-15.6	54	12.2	104	40.0	154	67.8
5	-15.0	55	12.8	105	40.6	155	68.3
6	-14.4	56	13.3	106	41.1	156	68.9
7	-13.9	57	13.9	107	41.7	157	69.4
8	-13.3	58	14.4	108	42.2	158	70.0
9	-12.8	59	15.0	109	42.8	159	70.6
10	-12.2	60	15.6	110	43.3	160	71.1
11	-11.7	61	16.1	111	43.9	161	71.7
12	-11.1	62	16.7	112	44.4	162	72.2
13	-10.6	63	17.2	113	45.0	163	72.8
14	-10.0	64	17.8	114	45.6	164	73.3
15	-9.4	65	18.3	115	46.1	165	73.9
16	-8.9	66	18.9	116	46.7	166	74.4
17	-8.3	67	19.4	117	47.2	167	75.0
18	-7.8	68	20.0	118	47.8	168	75.6
19	-7.2	69	20.6	119	48.3	169	76.1
20	-6.7	70	21.1	120	48.9	170	76.7
21	-6.1	71	21.7	121	49.4	171	77.2
22	-5.6	72	22.2	122	50.0	172	77.8
23	-5.0	73	22.8	123	50.6	173	78.3
24	-4.4	74	23.3	124	51.1	174	78.9
25	-3.9	75	23.9	125	51.7	175	79.4
26	-3.3	76	24.4	126	52.2	176	80.0
27	-2.8	77	25.0	127	52.8	177	80.6
28	-2.2	78	25.6	128	53.3	178	81.1
29	-1.7	79	26.1	129	53.9	179	81.7
30	-1.1	80	26.7	130	54.4	180	82.2
31	-0.6	81	27.2	131	55.0	181	82.8
32	0.0	82	27.8	132	55.6	182	83.3
33	0.6	83	28.3	133	56.1	183	83.9
34	1.1	84	28.9	134	56.7	184	84.4
35	1.7	85	29.4	135	57.2	185	85.0
36	2.2	86	30.0	136	57.8	186	85.6
37	2.7	87	30.6	137	58.3	187	86.1
38	3.3	88	31.1	138	58.9	188	86.7
39	3.9	89	31.7	139	59.4	189	87.2
40	4.4	90	32.2	140	60.0	190	87.8
41	5.0	91	32.8	141	60.6	191	88.3
42	5.6	92	33.3	142	61.1	192	88.9
43	6.1	93	33.9	143	61.7	193	89.4
44	6.7	94	34.4	144	62.2	194	90.0
45	7.2	95	35.0	145	62.8	195	90.6
46	7.8	96	35.6	146	63.3	196	91.1
47	8.3	97	36.1	147	63.9	197	91.7
48	8.9	98	36.7	148	64.4	198	92.2
49	9.4	99	37.2	149	65.0	199	92.8
50	10.0	100	37.8	150	65.5	200	93.3

A

Appendix A

MILES PER HOUR TO KILOMETERS
PER HOUR CONVERSION TABLE
1 MPH = 1.609 KM/H

MPH	KM/H	MPH	KM/H	MPH	KM/H
10	16.09	1	1.61	0.1	0.16
20	32.19	2	3.22	0.2	0.32
30	48.28	3	4.83	.03	0.48
40	64.37	4	6.44	0.4	0.64
50	80.47	5	8.05	0.5	0.80
60	96.56	6	9.66	0.6	0.97
70	112.65	7	11.27	0.7	1.13
80	128.75	8	12.87	0.8	1.29
90	144.84	9	14.48	0.9	1.45
100	160.93	10	16.09	1.0	1.61

U.S. GALLONS TO LITERS CONVERSION TABLE
1 U.S. GALLON = 3.785 LITERS

GAL	LITER	GAL	LITER	GAL	LITER	GAL	LITER
100	378.54	10	37.85	1	3.79	0.1	0.38
200	757.08	20	75.71	2	7.57	0.2	0.76
300	1,135.62	30	113.56	3	11.36	0.3	1.14
400	1,514.16	40	151.42	4	15.14	0.4	1.51
500	1,892.71	50	189.27	5	18.93	0.5	1.89
600	2,271.25	60	227.12	6	22.71	0.6	2.27
700	2,649.79	70	264.98	7	26.50	0.7	2.65
800	3,028.33	80	302.83	8	30.28	0.8	3.03
900	3,406.87	90	340.69	9	34.07	0.9	3.41
1,000	3,785.41	100	378.54	10	37.85	1.0	3.79



APPENDIX B - SAE J1273

- * SAE J1273 - AUG 2004
Recommended Practices for Hydraulic Hose Assemblies
- * Reprinted with permission SAE J1273 AUG 2004 - © 2004 SAE International

DISCLAIMER

HARSCO RAIL RECOMMENDS THAT ALL HOSE, HOSE ASSEMBLIES AND/OR FITTINGS REPLACED BY THE CUSTOMER SHOULD BE EQUAL TO OR EXCEED THE CURRENT SPECIFICATIONS OF THE ORIGINAL EQUIPMENT SUPPLIED BY HARSCO RAIL. HARSCO RAIL WILL NOT BE LIABLE FOR ANY CLAIMS OF PERSONAL INJURY RESULTING FROM THE USE OF HOSE, HOSE ASSEMBLIES AND/OR FITTINGS THAT DO NOT MEET CURRENT ORIGINAL EQUIPMENT SPECIFICATIONS. THE CUSTOMER IS ADVISED TO COMPLY WITH SAE J1273 AUGUST 2004, RECOMMENDED PRACTICES FOR HYDRAULIC HOSE ASSEMBLIES.

 SURFACE VEHICLE RECOMMENDED PRACTICE	SAE J1273	REV. AUG2004
	Issued 1979-09 Revised 2004-08	
	Superseding J1273 DEC2002	

Recommended Practices for Hydraulic Hose Assemblies

Foreword—This SAE Recommended Practice is intended as a guide to consider when selecting, routing, fabricating, installing, replacing, maintaining, and storing hose for fluid-power systems. It is subject to change to keep pace with experience and technical advances. For those new to hose use in fluid-power systems, this guide outlines practices to note during each phase of system design and use. Experienced designers and users skilled in achieving proper results, as well as the less experienced, can use this outline as a list of considerations to keep in mind.

Fluid power systems are complex and require extensive knowledge of both the system requirements and the various types of hose. Therefore, all-inclusive, detailed, step-by-step instructions are not practical and are beyond the scope of this document. Less experienced designers and users who need more information can consult specialists such as hose suppliers and manufacturers. This guide can improve the communication process.

Safety Considerations—These recommended practices involve safety considerations; note these carefully during all phases of design and use of hose systems. Improper selection, fabrication, installation, or maintenance of hose and hose assemblies for fluid-power systems may result in serious personal injury or property damage. These recommended practices can reduce the likelihood of component or system failure, thereby reducing the risk of injury or damage.

TABLE OF CONTENTS

1.	Scope	2
2.	References	2
3.	Explanation of Terms	2
4.	Safety Considerations	2
5.	Hose Selection and Routing	3
6.	Hose-Assembly Fabrication	10
7.	Hose Installation and Replacement	11
8.	Maintenance Inspection	13

SAE Technical Standards Board Rules provide that: "This report is published by SAE to advance the state of technical and engineering sciences. The use of this report is entirely voluntary, and its applicability and suitability for any particular use, including any patent infringement arising therefrom, is the sole responsibility of the user."

SAE reviews each technical report at least every five years at which time it may be reaffirmed, revised, or cancelled. SAE invites your written comments and suggestions.

Copyright © 2004 SAE International

All rights reserved. No part of this publication may be reproduced, stored in a retrieval system or transmitted, in any form or by any means, electronic, mechanical, photocopying, recording, or otherwise, without the prior written permission of SAE.

TO PLACE A DOCUMENT ORDER:

Tel: 877-606-7323 (inside USA and Canada)
Tel: 724-776-4970 (outside USA)
Fax: 724-776-0790
Email: custsvc@sae.org
<http://www.sae.org>

SAE WEB ADDRESS:



SAE J1273 Revised AUG2004

9. Hose Storage 13
10. Notes 14

1. **Scope**—SAE J1273 provides guidelines for selection, routing, fabrication, installation, replacement, maintenance, and storage of hose and hose assemblies for fluid-power systems. Many of these SAE Recommended Practices also may be suitable for other hoses and systems.

2. **References**

2.1 **Applicable Publications**—The following publications form a part of this specification to the extent specified herein. Unless otherwise specified, the latest issue of SAE publications shall apply.

2.1.1 SAE PUBLICATIONS—Available from SAE, 400 Commonwealth Drive, Warrendale, PA 15096-0001.

SAE J343—Test and Procedures for SAE 100 R Series Hydraulic Hose and Hose Assemblies

SAE J514—Hydraulic Tube Fittings

SAE J517—Hydraulic Hose

SAE J1927—Cumulative Damage Analysis for Hydraulic Hose Assemblies

2.1.2 ISO PUBLICATION—Available from ANSI, 25 West 43rd Street, New York, NY 10036-8002.

ISO 3457—Earth moving machinery—Guards and shields—Definitions and specifications

3. **Definitions**—These explanations serve only to clarify this document and are not intended to stand alone. They are presented sequentially, with the former helping to explain the latter.

3.1 **Fluid Power**—Energy transmitted and controlled using pressurized hydraulic fluids or compressed air.

3.2 **Hose**—Flexible conductor. In this document, the term hose also may refer to a hose assembly with related accessories used in fluid power applications.

3.3 **Hose Fitting or Fitting**—Connector which can be attached to the end of a hose.

3.4 **Hose Assembly**—Hose with hose fittings attached.

3.5 **Hose Failure**—Occurrence in which a hose stops meeting system requirements.

3.6 **Hose Service Life**—Length of time a hose meets system requirements without needing replacement.

4. **Safety Considerations**—Listed in 4.1 to 4.7 are some potential conditions and situations that may lead to personal injury and/or property damage. This list is not necessarily all inclusive. Consider reasonable and feasible means, including those described in this section, to reduce the risk of injuries or property damage.

Training, including the information in this document, for operators, maintenance personnel, and other individuals working with hoses under pressure is encouraged.

4.1 **Fluid Injections**—Fine streams of escaping pressurized fluid can penetrate skin and enter a human body. These fluid injections may cause severe tissue damage and loss of limb.

Consider various means to reduce the risk of fluid injections, particularly in areas normally occupied by operators. Consider careful routing, adjacent components, warnings, guards, shields, and training programs.

SAE J1273 Revised AUG2004

Relieve pressure before disconnecting hydraulic or other lines. Tighten all connections before applying pressure.

Avoid contact with escaping fluids. Treat all leaks as though pressurized and hot enough to burn skin. Never use any part of your body to check a hose for leaks.

If a fluid-injection accident occurs, see a doctor immediately. **DO NOT DELAY OR TREAT AS A SIMPLE CUT!** Any fluid injected into the skin must be surgically removed *within a few hours* or gangrene may result. Doctors unfamiliar with this type of injury should consult a knowledgeable medical source.

- 4.2 Whipping Hose**—If a pressurized hose assembly blows apart, the fittings can be thrown off at high speed, and the loose hose can flail or whip with great force. This is particularly true in compressible-fluid systems.

When this risk exists, consider guards and restraints to protect against injury.

- 4.3 Burns from Conveyed Fluids**—Fluid-power media may reach temperatures that can burn human skin. If there is risk of burns from escaping fluid, consider guards and shields to prevent injury, particularly in areas normally occupied by operators.

- 4.4 Fire and Explosions from Conveyed Fluids**—Most fluid-power media, including fire-resistant hydraulic fluids, will burn under certain conditions. Fluids which escape from pressurized systems may form a mist or fine spray which can flash or explode upon contact with an ignition source.

Consider selecting, guarding, and routing hose to minimize the risk of combustion (see Section 5 and ISO 3457).

- 4.5 Fire and Explosions from Static-Electric Discharge**—Fluid passing through hose can generate static electricity, resulting in static-electric discharge. This may create sparks that can ignite system fluids or gases in the surrounding atmosphere.

When this potential exists, select hose specifically designed to carry the static-electric charge to ground.

- 4.6 Electrical Shock**—Electrocution could occur if hose conducts electricity through a person. Most hoses are conductive. Many contain metal or have metal fittings. Even nonconductive hoses can be conduits for electricity if they carry conductive fluids.

Be aware of routing or using hose near electrical sources. When this cannot be avoided, select appropriate hose. Nonconductive hoses should be considered. SAE J517—100R7 and 100R8 hoses, with orange covers marked "Nonconductive" are available for applications requiring nonconductive hose.

- 4.7 Mechanisms Controlled by Fluid Power**—Mechanisms controlled by fluids in hoses can become hazardous when a hose fails. For example, when a hose bursts, objects supported by fluid pressure may fall, or vehicles or machines may lose their brakes or steering.

If mechanisms are controlled by fluid power, consider safe modes of failure that minimize risks of injury or damage.

- 5. Hose Selection and Routing**—A wide variety of interacting factors influence hose service life and the ability of each fluid-power system to operate satisfactorily, and the combined effects of these factors on service life are often unpredictable. Therefore, these documents should not be construed as design standards. For applications outside the specifications in SAE J517, SAE J514, or other relevant design standards, performance of hose assemblies should be determined by appropriate testing.

SAE J1273 Revised AUG2004

Carefully analyze each system. Then design routings and select hose and related components to meet the system-performance and hose-service-life requirements, and to minimize the risks of personal injury and/or property damage. Consider the following factors:

- 5.1 System Pressures**—Excessive pressure can accelerate hose assembly failure. Analyze the steady-state pressures, and the frequency and amplitude of pressure surges, such as pulses and spikes. These are rapid and transient rises in pressure which may not be indicated on many common pressure gages and can be identified best on high-frequency-response electronic measuring instruments.

For maximum hose service life, hose selection should be based on a system pressure, including surges, that is less than the hose maximum working pressure. Hose may be used above its maximum working pressure where reduced life expectancy is acceptable. SAE J1927 provides one method to help predict wire-reinforced hose service life for a given hydraulic application, where the surge pressure peaks vary, and/or the highest pressure peaks occur infrequently.

- 5.2 Suction**—For suction applications, such as inlet flow to pumps, select hose to withstand both the negative and positive pressures the system imposes on the hose.
- 5.3 External Pressure**—In certain applications, such as in autoclaves or under water, the external environmental pressures may exceed the fluid pressure inside the hose. In these applications, consider the external pressures, and if necessary, consult the manufacturers.
- 5.4 Temperature**—Exceeding hose temperature ratings may significantly reduce hose life. Select hose so the fluid and ambient temperatures, both static and transient, fall within the hose ratings. The effects of external heat sources should not raise the temperature of the hose above its maximum operating temperature. Select hose, heat shields, sleeving, and other methods for these requirements, and route or shield hose to avoid hose damage from external heat sources.
- 5.5 Permeation**—Permeation, or effusion, is seepage of fluid through the hose. Certain materials in hose construction are more permeable than others. Consider the effects of permeation when selecting hose, especially with gaseous fluids. Consult the hose and fluid manufacturers for permeability information.
- 5.6 Hose-Material Compatibility**—Variables that can affect compatibility of system fluids with hose materials include, but are not limited to:

- a. Fluid pressure
- b. Temperature
- c. Concentration
- d. Duration of exposure

Because of permeation (see 5.5), consider compatibility of system fluids with the hose, tube, cover, reinforcement, and fittings. Consult the fluid and hose manufacturers for compatibility information.

NOTE—Many fluid/elastomer compatibility tables in manufacturers' catalogs show ratings based on fluids at 21 °C, room temperature. These ratings may change at other temperatures. Carefully read the notes on the compatibility tables, and if in doubt, consult the manufacturer.

SAE J1273 Revised AUG2004

5.7 Environment—Environmental conditions can cause hose and fitting degradation. Conditions to evaluate include, but are not limited to:

- a. Ultraviolet light
- b. Salt water
- c. Air pollutants
- d. Temperature (see 5.4)
- e. Ozone
- f. Chemicals
- g. Electricity
- h. Abrasion

If necessary, consult the manufacturers for more information.

5.8 Static-Electric Discharge—Fluid passing through hose can generate static electricity resulting in static-electric discharge. This may create sparks that can puncture hose. If this potential exists, select hose with sufficient conductivity to carry the static-electric charge to ground.

5.9 Sizing—The power transmitted by pressurized fluid varies with pressure and rate of flow. Select hose with adequate size to minimize pressure loss, and to avoid hose damage from heat generation or excessive velocity. Conduct calculations, or consult the manufacturers for sizing at flow velocities.

5.10 Unintended Uses—Hose assemblies are designed for the internal forces of conducted fluids. Do not pull hose or use it for purposes that may apply external forces for which the hose or fittings were not designed.

5.11 Specifications and Standards—When selecting hose and fittings for specific applications, refer to applicable government, industry, and manufacturer's specifications and standards.

5.12 Unusual Applications—Applications not addressed by the manufacturer or by industry standards may require special testing prior to selecting hose.

5.13 Hose Cleanliness—The cleanliness requirements of system components, other than hose, will determine the cleanliness requirements of the application. Consult the component manufacturers' cleanliness information for all components in the system. Hose assemblies vary in cleanliness levels; therefore, specify hose assemblies with adequate cleanliness for the system.

5.14 Hose Fittings—Selection of the proper hose fittings for the hose and application is essential for proper operation and safe use of hose and related assembly equipment. Hose fittings are qualified with the hose. Therefore, select only hose fittings compatible with the hose for the applications.

Improper selection of hose fittings or related assembly equipment for the application can result in injury or damage from leaks, or from hose assemblies blowing apart (see 4.2, 6.2, 6.3, and 6.4).

5.15 Vibration—Vibration can reduce hose service life. If required, conduct tests to evaluate the frequency and amplitude of system vibration. Clamps or other means may be used to reduce the effects of vibration. Consider the vibration requirements when selecting hose and predicting service life.

5.16 Hose Cover Protection—Protect the hose cover from abrasion, erosion, snagging, and cutting. Special abrasion-resistant hoses and hose guards are available for additional protection. Route hose to reduce abrasion from hose rubbing other hose or objects that may abrade it. (See Figure 1)

SAE J1273 Revised AUG2004

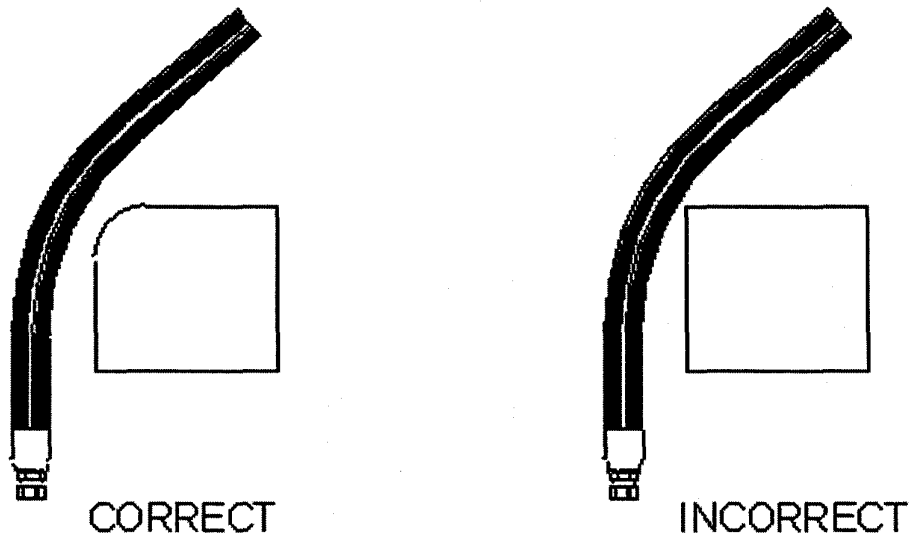

FIGURE 1—PREVENTION OF EXTERNAL DAMAGE

5.17 External Physical Abuse—Route hose to avoid:

- a. Tensile loads
- b. Side loads
- c. Flattening
- d. Thread damage
- e. Kinking
- f. Damage to sealing surfaces
- g. Abrasion
- h. Twisting

5.18 Swivel-Type Adapters—Swivel-type fittings or adapters do not transfer torque to hose while being tightened. Use these as needed to prevent twisting during installation.

5.19 Live Swivels—If two components in the system are rotating in relation to each other, live swivels may be necessary. These connectors reduce the torque transmitted to the hose.

5.20 Slings and Clamps—Use slings and clamps to support heavy or long hose and to keep it away from moving parts. Use clamps that prevent hose movement that will cause abrasion.

5.21 Minimum Bend Radius—The minimum bend radius is defined in SAE J343 and is specified in other SAE standards and hose manufacturer's product literature. Routing at less than minimum bend radius may reduce hose life. Sharp bending at the hose/fitting juncture may result in leaking, hose rupturing, or the hose assembly blowing apart (see 4.2 and Figures 2A and 2B).

SAE J1273 Revised AUG2004

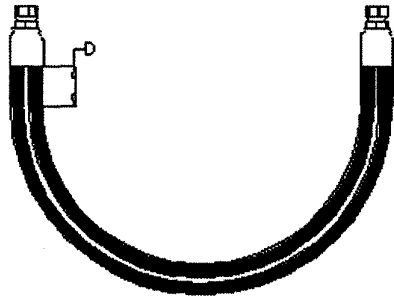

CORRECT



INCORRECT

FIGURE 2A—MINIMUM BEND RADIUS

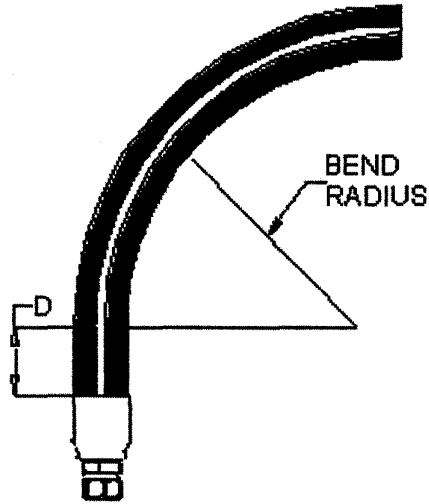

CORRECT

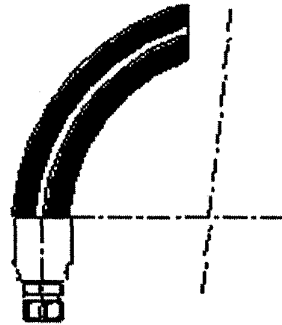

INCORRECT

FIGURE 2B—MINIMUM BEND RADIUS

B

SAE J1273 Revised AUG2004

5.22 Elbows and Adapters—In special cases, use elbows or adapters to relieve hose strain (see Figure 3).

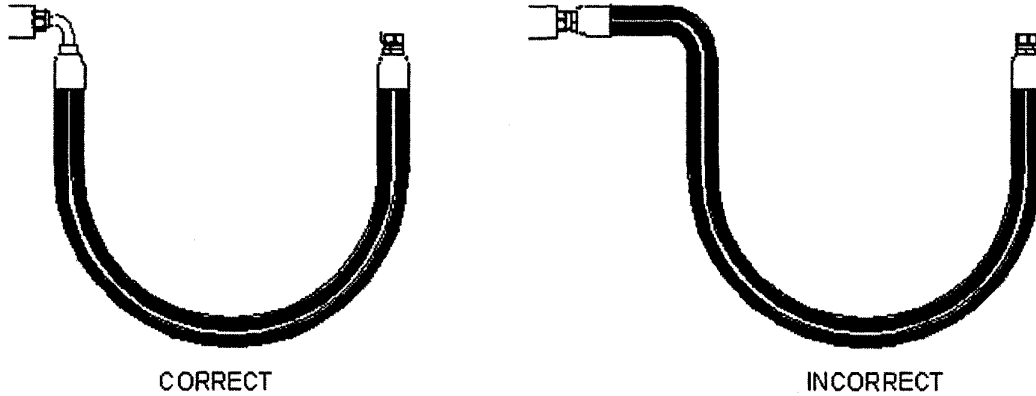

FIGURE 3—ELBOWS AND ADAPTERS

5.23 Lengths—Unnecessarily long hose can increase pressure drop and affect system performance. When pressurized, hose that is too short may pull loose from its fittings, or stress the fitting connections, causing premature metallic or seal failures. When establishing hose length, refer to Figures 4, 5, and 6; and use the following practices:

5.23.1 MOTION ABSORPTION—Provide adequate hose length to distribute movement and prevent bends smaller than the minimum bend radius.

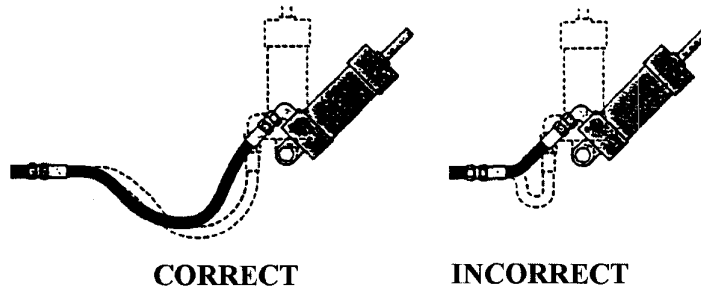

FIGURE 4—MOTION ABSORPTION

5.23.2 HOSE AND MACHINE TOLERANCES—Design hose to allow for changes in length due to machine motion and tolerances.

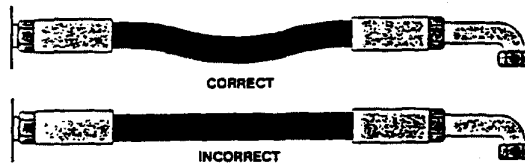

FIGURE 5—HOSE AND MACHINE TOLERANCES

SAE J1273 Revised AUG2004

5.23.3 HOSE LENGTH CHANGE DUE TO PRESSURE—Design hose to accommodate length changes from changing pressures. Do not cross or clamp together high- and low-pressure hoses. The difference in length changes could wear the hose covers.

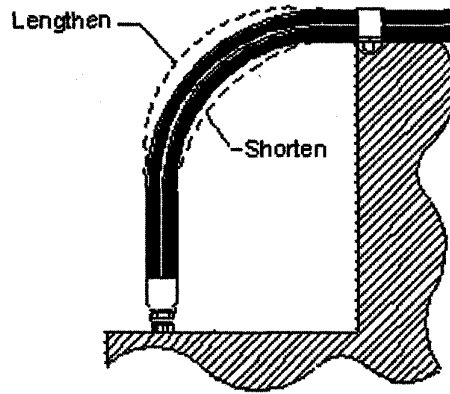

FIGURE 6—HOSE LENGTH CHANGE DUE TO PRESSURE

5.24 Hose Movement and Bending—Hose allows relative motion between system components. Analyze this motion when designing hose systems. The number of cycles per day may significantly affect hose life. Also avoid multiple planes of motion and twisting motion. Consider the motion of the hose when selecting hose and predicting service life. In applications that require hose to move or bend, refer to Figures 7A, 7B, and 8; and use these practices:

5.24.1 BEND IN ONLY ONE PLANE TO AVOID TWISTING

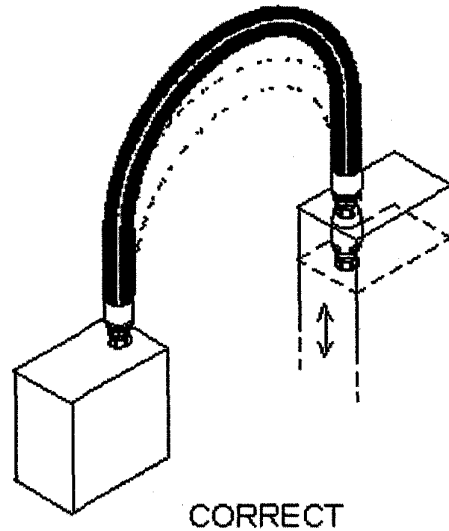

FIGURE 7A—BEND IN ONLY ONE PLANE TO AVOID TWISTING

B

SAE J1273 Revised AUG2004

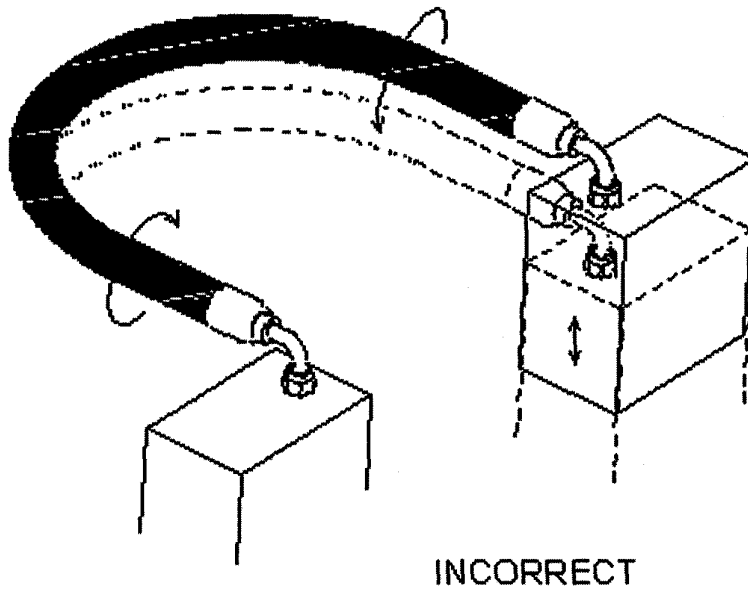

FIGURE 7B—BEND IN ONLY ONE PLANE TO AVOID TWISTING

5.24.2 PREVENT HOSE BENDING IN MORE THAN ONE PLANE—If hose follows a compound bend, couple it into separate segments, or clamp it into segments that flex in only one plane.

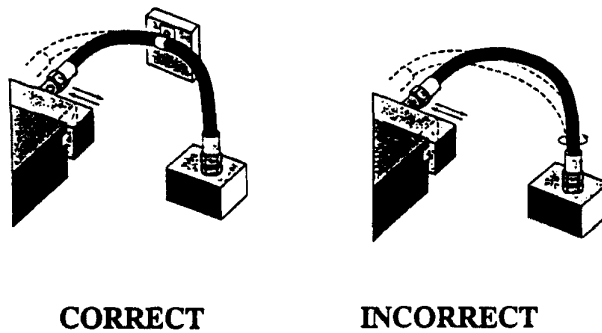

FIGURE 8—PREVENT HOSE BENDING IN MORE THAN ONE PLANE

6. **Hose-Assembly Fabrication**—Persons fabricating hose assemblies should be trained in the proper use of equipment and materials. The manufacturers' instructions and the practices listed as follows must be followed. Properly assembled fittings are vital to the integrity of a hose assembly. Improperly assembled fittings can separate from the hose and may cause serious injury or property damage from whipping hose, or from fire or explosion of vapor expelled from the hose.

SAE J1273 Revised AUG2004

6.1 Component Inspection—Prior to assembly, examine components for:

- a. Style or type
- b. Cleanliness
- c. Loose covers
- d. Nicks
- e. Size
- f. Inside obstructions
- g. Visible defects
- h. Damage
- i. Length
- j. Blisters
- k. Burrs

6.2 Hose Fittings—Hose fitting components from one manufacturer are not usually compatible with fitting components supplied by another manufacturer. For example, do not use a hose fitting nipple from one manufacturer with a hose socket from another manufacturer.

It is the responsibility of the fabricator to consult the manufacturer's written instructions or the manufacturer directly for information on proper fitting components.

6.3 Hose and Fitting Compatibility—Care must be taken to determine proper compatibility between the hose and fitting. Base selection on the manufacturers' recommendations substantiated by testing to industry standards such as SAE J517. Hose from one manufacturer is not usually compatible with fittings from another. Do not intermix hose and fittings from two manufacturers without approval from both manufacturers.

6.4 Hose Assembly Equipment—Assembly equipment from one manufacturer is usually not interchangeable with that from another manufacturer. Hoses and fittings from one manufacturer should not generally be assembled with the equipment of another manufacturer.

6.5 Safety Equipment—During fabrication, use proper safety equipment, including eye protection, breathing apparatus, and adequate ventilation.

6.6 Reuse of Hose and Fittings—When fabricating hose assemblies, do **not** reuse:

- a. Field-attachable fittings that have blown or pulled off hose
- b. Any part of hose fittings that were permanently crimped or swaged to hose
- c. Hose that has been in service after system checkout (see 7.7)

6.7 Cleanliness of Hose Assemblies—Hose assemblies may be contaminated during fabrication. Clean hoses to specified cleanliness levels (see 5.13).

7. Hose Installation and Replacement—Use the following practices when installing hose assemblies in new systems or replacing hose assemblies in existing systems:

7.1 Pre-Installation Inspection—Before installing hose assemblies, examine:

- a. Hose length and routing for compliance with original design
- b. Assemblies for correct style, size, length, and visible nonconformities
- c. Fitting sealing surfaces for burrs, nicks, or other damage

NOTE—When replacing hose assemblies in existing systems, verify that the replacement is of equal quality to the original assembly.

B

SAE J1273 Revised AUG2004

- 7.2 **Handling During Installation**—Handle hose with care during installation. Kinking hose, or bending at less than minimum bend radius may reduce hose life. Avoid sharp bending at the hose/fitting juncture (see 5.21).
- 7.3 **Twist Angle and Orientation**—Pressure applied to a twisted hose may shorten the life of the hose or loosen the connections. To avoid twisting, use the hose lay line or marking as a reference (see Figure 9).

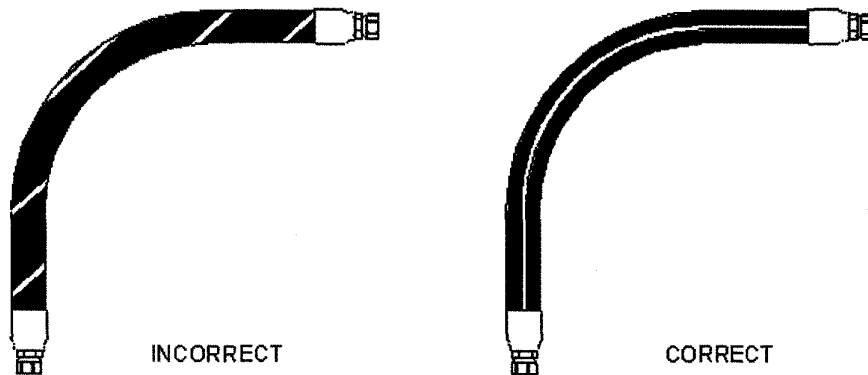

FIGURE 9—TWIST ANGLE AND ORIENTATION

- 7.4 **Securement and Protection**—Install necessary restraints and protective devices. Determine that such devices do not create additional stress or wear points.
- 7.5 **Routing**—Review proper routing practices provided in Section 5 and make appropriate corrections to obtain optimum performance.
- 7.6 **Assembly Torque**—The connection end of a hose fitting is normally threaded to obtain a tight pressure seal when attached to a port, an adapter, or another fitting. Sometimes bolts or screws provide the threaded connection. Each size and type of connection requires different torque values, and these may vary due to type of material or exterior coating.

Follow appropriate torquing instructions to obtain a proper pressure seal without over-torquing. A properly calibrated torque wrench should be used to tighten each connection, except when the manufacturer specifies tightening a specified number of hex flat turns beyond finger tight to obtain a seal.
- 7.7 **System Checkouts**—In hydraulic or other liquid systems, eliminate all air entrapment after completing the installation. Follow manufacturers' instructions to test the system for possible malfunctions and leaks.
 - 7.7.1 To avoid injury during system checkouts:
 - a. Do not touch any part of the system when checking for leaks (see 4.1).
 - b. Stay out of potentially hazardous areas while testing hose systems (see Section 4).
 - c. Relieve system pressure before tightening connections.

SAE J1273 Revised AUG2004

8. Maintenance Inspection—A hose and fitting maintenance program may reduce equipment downtime, maintain peak operating performance, and reduce the risk of personal injury and/or property damage. The user should design and implement a maintenance program that suits the specific application and each specific hose in that application.

8.1 Inspection Frequency—Evaluate factors such as the nature and severity of the application, past history, and manufacturers' information to establish the frequency of visual inspections and functional tests.

8.2 Visual Inspection (Hose and Fittings)—Visually inspect hose and fittings for:

- a. Leaks at hose fitting or in hose
- b. Damaged, cut, or abraded cover
- c. Exposed reinforcement
- d. Kinked, crushed, flattened, or twisted hose
- e. Hard, stiff, heat cracked, or charred hose
- f. Blistered, soft, degraded, or loose cover
- g. Cracked, damaged, or badly corroded fittings
- h. Fitting slippage on hose
- i. Other signs of significant deterioration

If any of these conditions exist, evaluate the hose assemblies for correction or replacement.

8.3 Visual Inspection (All Other Components)—When visually inspecting hose and fittings, inspect for related items including:

- a. Leaking ports
- b. Damaged or missing hose clamps, guards, or shields
- c. Excessive dirt and debris around hose
- d. System fluid: level, type, contamination, condition, and air entrainment

If any of these are found, address them appropriately.

8.4 Functional Test—Functional tests determine if systems with hose are leak free and operating properly. Carry out functional tests per information from equipment manufacturers.

9. Hose Storage—Age control and the manner of storage can affect hose life. Use the following practices when storing hose.

9.1 Age Control—Maintain a system of age control to determine that hose is used before its shelf life has expired. Shelf life is the period of time when it is reasonable to expect the hose to retain full capabilities for rendering the intended service.

Store hose in a manner that facilitates age control and first-in, first-out usage based on manufacturing date on hose or hose assembly. Per SAE J517:

- a. Shelf life of rubber hose in bulk form, or in hose assemblies passing visual inspection and proof test, is forty quarters (ten years) from the date of manufacture.
- b. Shelf life of thermoplastic and polytetrafluoroethylene hose is considered to be unlimited.

SAE J1273 Revised AUG2004

9.2 Storage—Store hose and hose assemblies in a cool, dark, dry area with the ends capped. When storing hose, take care to avoid damage that could reduce hose life, and follow the manufacturers' information for storage and shelf life. Examples of factors that can adversely affect hose products in storage are:

- a. Temperature
- b. Ozone
- c. Oils
- d. Corrosive liquids and fumes
- e. Rodents
- f. Humidity
- g. Ultraviolet light
- h. Solvents
- i. Insects
- j. Radioactive materials

If there are questions regarding the quality or usability of hose or hose assemblies, evaluate appropriately:

- a. Flex the hose to the minimum bend radius and compare it with new hose. After flexing, examine the cover and tube for cracks. If any appear, no matter how small, reject the hose.
- b. If the hose is wire reinforced, and the hose is unusually stiff, or a cracking sound is heard during flexing, check for rust by cutting away a section of the cover from a sample. Rust would be another reason for rejection.
- c. If doubt still persists, contact hose assembler to conduct proof-pressure tests or any other tests needed to verify hose quality.

10. Notes

10.1 Marginal Indicia—The (R) is for the convenience of the user in locating areas where technical revisions have been made to the previous issue of the report. If the symbol is next to the report title, it indicates a complete revision of the report.

PREPARED BY THE SAE FLUID CONDUCTORS AND CONNECTORS TECHNICAL COMMITTEE SC3—
TRAINING AND EDUCATION SUBCOMMITTEE

SAE J1273 Revised AUG2004

Rationale—To correct verbiage in Section 9.1.

Relationship of SAE Standard to ISO Standard—Not applicable.

Application—SAE J1273 provides guidelines for selection, routing, fabrication, installation, replacement, maintenance, and storage of hose and hose assemblies for fluid-power systems. Many of these SAE Recommended Practices also may be suitable for other hoses and systems.

Reference Section

SAE J343—Test and Procedures for SAE 100 R Series Hydraulic Hose and Hose Assemblies

SAE J514—Hydraulic Tube Fittings

SAE J517—Hydraulic Hose

SAE J1927—Cumulative Damage Analysis for Hydraulic Hose Assemblies

ISO 3457—Earth moving machinery—Guards and shields—Definitions and specifications

Developed by the SAE Fluid Conductors and Connectors Technical Committee SC3—Training and Education Subcommittee

Sponsored by the SAE Fluid Conductor and Connectors Technical Committee

Limited Warranty

Harsco Rail warrants products of its manufacture to be free of defects in material and workmanship, under normal use and service for a period of six (6) months from date of delivery to the original user. The obligation of Harsco Rail under this warranty is limited to repairing or replacing at its factories, or other location designated by it, any part or parts thereof which are returned within 30 days of the date when failure occurs or defect is noted, with transportation charges prepaid, and which upon examination appears to the satisfaction of Harsco Rail to have been defective. Such free repair or replacement does not include transportation charges, or the cost of installing the new part or any other expense incident thereto. Harsco Rail will not be liable for other loss, damage, or expense directly or indirectly arising from the use of its product, nor will Harsco Rail be liable for special, incidental, or consequential damages.

Ordinary wear and tear, and damage from abuse, misuse, neglect or alteration are not covered by this warranty. Harsco Rail assumes no liability for expense incurred or repairs made outside its factories except by written consent. This warranty is null and void if instructions and operating procedures are not followed.

Equipment and parts not manufactured by Harsco Rail, but which are furnished in connection with Harsco Rail products, are covered directly by the warranty of the manufacturer supplying them. However, Harsco Rail will assist in obtaining adjustment on such equipment or parts when necessary.

THIS WARRANTY IS IN LIEU OF ALL OTHER WARRANTIES EXPRESSED OR IMPLIED INCLUDING ANY IMPLIED WARRANTIES OF MERCHANTABILITY OR FITNESS FOR A PARTICULAR PURPOSE, WHICH ARE HEREBY DISCLAIMED AND OF ANY OTHER OBLIGATION OR LIABILITY OF HARSCO RAIL. THE REMEDY SET FORTH ABOVE IS BUYER'S EXCLUSIVE REMEDY FOR A BREACH OF THE WARRANTY. UNDER NO CIRCUMSTANCES WILL HARSCO RAIL BE RESPONSIBLE FOR INCIDENTAL, CONSEQUENTIAL, SPECIAL OR OTHER INDIRECT DAMAGES.

Indemnity

Buyer agrees to indemnify and hold Harsco Rail harmless for all loss, cost including but not limited to legal and other cost of proceedings, and damages suffered by Buyer or claimed by third parties by or related to Buyer's use of Harsco Rail's products.

Product Improvement Liability Disclaimer

Harsco Rail reserves the right to make any changes in or improvements to its products without incurring any liability or obligation whatsoever and without being required to make any corresponding changes or improvements to products previously manufactured or sold.

Hazardous Material Disclaimer

The parts/assemblies that are used in this Product are classified as "articles" according to 29 CFR 1910.1200 (C). They are formed to a specific shape or design during manufacture, have end use function dependent upon their shape or design, and do not release any hazardous chemical under normal conditions of use. Accordingly, we are not required to supply Material Safety Data Sheets (MSDS) or to label shipping containers for "articles". However, lubricants, liquids, gaseous chemicals and solids used in operation or maintenance of the product may require that user's take occupational protective measures. MSDS sheets for such materials will be supplied to your Purchasing Manager/Safety Director to be used in your employee safety training education and environmental health training.

HARSCO

RAIL

HARSCO RAIL
HARSCO CORPORATION
415 North Main Street
Fairmont, Minnesota, 56031-1837 U.S.A.

BULLETIN 1269A

Printed In U.S.A.

ISSUED 3 - 2011

© 2011 HARSCO RAIL, HARSCO CORPORATION