

HTT

Harsco Track Technologies

Harsco

**HR4000 SERIES C1
FRONT UNIVERSAL HY-RAIL®
GUIDE WHEEL UNIT
HYDRAULICALLY OPERATED**

**OPERATOR'S SERVICE
AND PARTS MANUAL**

ISSUED 9 - 2004

BULLETIN 1442

© 2004 HARSCO TRACK TECHNOLOGIES, HARSCO CORPORATION



■ **THIS MANUAL CONTAINS VITAL INFORMATION FOR THE SAFE USE AND EFFICIENT OPERATION OF THE VEHICLE EQUIPPED WITH HY-RAIL® GUIDE WHEEL EQUIPMENT. CAREFULLY READ THIS OPERATOR'S MANUAL BEFORE USING THE VEHICLE. FAILURE TO ADHERE TO THE INSTRUCTIONS COULD RESULT IN BODILY INJURY AND/OR PROPERTY DAMAGE.**

HARSCO TRACK TECHNOLOGIES is the brand name and trademark of products manufactured by Harsco Track Technologies, Harsco Corporation.

HY-RAIL® is a registered trademark of Harsco Track Technologies, Harsco Corporation.

When this manual is received, record the rail pilot unit serial numbers in the spaces provided in the General Information and Parts Sections for future reference, in case the serial number tags ever become unreadable. A Manual must remain with the vehicle. Additional or replacement manuals may be obtained by calling or writing Harsco Track Technologies, Harsco Corporation.

All information, illustrations and specifications in this manual are based on the latest information available at the time of publication. Harsco Track Technologies, Harsco Corporation reserves the right to make changes at any time without notice.

FACILITY LOCATIONS

Harsco Track Technologies

415 North Main Street
Fairmont, MN
56031-1837
Tel: (507) 235-3361
Fax: (507) 235-7370

Harsco Track Technologies

200 South Jackson Road
Ludington, MI
49431
Tel: (231) 843-3431
Fax: (231) 843-4830

Harsco Track Technologies

2401 Edmund Road, Box 20
Cayce-West Columbia, SC
29171-0020
Tel: (803) 822-9160
Fax: (803) 822-7471

Harsco Track Technologies

Giltway, Giltbrook
Nottingham, NG16 2GQ
England
Tel: 0115 938 7000
Fax: 0115 938 7001

Harsco Track Technologies

4 Strathwyn Street, PO Box 5287
Brendale, Queensland 4500
Australia
Tel: 61 7 205 6500
Fax: 61 7 205 7369

TABLE OF CONTENTS

GENERAL INFORMATION

SECTION

1

OPERATION

SECTION

2

ADJUSTMENTS

SECTION

3

MAINTENANCE

SECTION

4

TROUBLESHOOTING

SECTION

5

APPENDICES

SECTION

6

PARTS

SECTION

7

VEHICLE APPLICATIONS

SECTION

8

SECTION

9

SECTION

10

SECTION 1 - GENERAL INFORMATION
TABLE OF CONTENTS

1.1	Safety Information	1 - 2
1.1.1	Hazard Seriousness	1 - 2
1.2	Description	1 - 5
1.3	Vehicle Orientation	1 - 5
1.4	Serial Numbers	1 - 6
1.5	Specifications	1 - 7
1.5.1	Vehicle	1 - 7
1.5.2	Guide Wheel Unit	1 - 7

1.1 Safety Information



SAFETY IS A CRITICAL FACTOR IN THE DESIGN OF HARSCO TRACK TECHNOLOGIES EQUIPMENT. THE BEST SAFETY PROGRAM STARTS WITH A SAFETY CONSCIOUS OPERATOR. THE SAFETY INFORMATION HIGHLIGHTED IN THIS BULLETIN DESCRIBES SAFE OPERATING PRACTICES FOR THE BENEFIT OF THE WORKERS WHO WILL USE OUR EQUIPMENT IN THEIR DAILY JOBS.

1.1.1 Hazard Seriousness

Signal Words: **DANGER**, **WARNING** and **CAUTION** are used to identify levels of hazard seriousness.



DANGER - Immediate hazards which WILL result in severe bodily injury or death.



WARNING - Hazards or unsafe practices which COULD result in severe bodily injury or death.



CAUTION - Hazards or unsafe practices which COULD result in minor bodily injury and / or product or property damage.

1.1 Safety Information



- **APPLY THE VEHICLE PARKING BRAKE AND STOP THE ENGINE WHEN PERFORMING MAINTENANCE, MAKING ADJUSTMENTS, WORKING UNDER VEHICLE OR GUIDE WHEEL EQUIPMENT OR WHENEVER UNINTENDED MOVEMENT OF THE VEHICLE COULD OCCUR, UNLESS OTHERWISE INSTRUCTED IN THIS MANUAL.**
- **MAKE SURE ALL PERSONS ARE CLEAR OF VEHICLE BEFORE PERFORMING ANY OPERATING FUNCTIONS.**
- **KEEP ALL PARTS OF THE BODY AND LOOSE CLOTHING CLEAR OF ALL MOVING PARTS OF THE VEHICLE OR GUIDE WHEEL EQUIPMENT.**
- **UNDERSTAND EQUIPMENT OPERATION AND BE AWARE OF ALL PINCH POINTS BEFORE OPERATING OR MAKING ADJUSTMENTS TO GUIDE WHEEL EQUIPMENT.**
- **IF A DERAILMENT SHOULD OCCUR WHILE VEHICLE IS OPERATING IN ELECTRIFIED 3RD-RAIL TERRITORY, VEHICLE OR GUIDE WHEEL EQUIPMENT MIGHT BE IN ELECTRICAL CONTACT WITH ELECTRIFIED RAIL. DO NOT ATTEMPT TO EXIT FROM VEHICLE UNTIL ELECTRICAL POWER TO 3RD-RAIL HAS BEEN TURNED OFF.**
- **DO NOT EXCEED 25 MPH (40 km/h) WHEN OPERATING VEHICLE ON TRACK. RAILROAD RULES GOVERNING SPEEDS SHOULD BE OBSERVED AT ALL TIMES. REDUCE SPEED WHEN PROPELLING VEHICLE THROUGH SWITCHES, CROSSINGS, BRANCH LINES AND ANY SPECIAL TRACK WORKS. OPERATING VEHICLE AT UNSAFE SPEEDS COULD RESULT IN DERAILMENT OF VEHICLE.**
- **CHECK AND CORRECT GUIDE WHEEL EQUIPMENT ALIGNMENT PROMPTLY IF MISALIGNMENT IS INDICATED.**

1

1.1 Safety Information



■ **AT MAXIMUM LOADED GROSS VEHICLE WEIGHT ON TRACK (including driver, passengers, equipment, tools, payload, etc.) DO NOT EXCEED ANY OF THE FOLLOWING:**

- **VEHICLE'S G.V.W.R. (Gross Vehicle Weight Rating).**
- **VEHICLE'S FRONT G.A.W.R. (Gross Axle Weight Rating) OR THE FRONT GUIDE WHEEL UNIT RATED LOAD CAPACITY, WHICHEVER IS LOWER.**
- **VEHICLE'S REAR G.A.W.R. (Gross Axle Weight Rating) OR THE SUM OF THE REAR GUIDE WHEEL UNIT RATED LOAD CAPACITY PLUS (+) VEHICLE'S REAR TIRE/WHEEL RATED LOAD CAPACITY, WHICHEVER IS LOWER.**
- **COMPONENTS RATED LOAD CAPACITY:**
 - A. **TIRE MANUFACTURER'S RATED LOAD CAPACITY**
 - B. **VEHICLE'S WHEEL RATED LOAD CAPACITY**
 - C. **FRONT GUIDE WHEEL UNIT RATED LOAD CAPACITY:**
 - 20,000 lbs (9,072 kg)
 - 10,000 lbs (4,536 kg) maximum per guide wheel

FAILURE TO HEED THESE WARNINGS COULD RESULT IN SEVERE BODILY INJURY.



■ **OBSERVE AND FOLLOW ALL RAILROAD SAFETY RULES AND REGULATIONS.**

■ **KNOW THE POSITIONS AND FUNCTIONS OF ALL CONTROLS BEFORE ATTEMPTING TO OPERATE VEHICLE.**

■ **THIS GUIDE WHEEL EQUIPMENT IS DESIGNED WITH YOUR SAFETY IN MIND. NEVER DISCONNECT AND/OR ATTEMPT TO OVERRIDE SAFETY FEATURES.**

FAILURE TO HEED THESE PRECAUTIONS COULD RESULT IN BODILY INJURY AND/OR PROPERTY DAMAGE.

Note: To help ensure safe operation of this equipment, keep all safety decals clean and legible. Replace safety decals when necessary with new decals, listed in the Parts Section of this manual.

1.2 Description

The HR4000 Series C1 HY-RAIL® guide wheel equipment can be applied to the front of various cab chassis trucks with single or tandem rear axles and dual wheels. The vehicle's G.V.W.R. (gross vehicle weight rating) and/or G.A.W.R. (gross axle weight rating) must comply with the specified limits listed in the Harsco Track Technologies HY-RAIL® Vehicle Specifications Manual. For information regarding special applications not listed in the Harsco Track Technologies HY-RAIL® Vehicle Specifications Manual, contact Harsco Track Technologies, Harsco Corporation, Fairmont, Minnesota.

The guide wheel unit is raised and lowered hydraulically. Hydraulic power may be supplied from the vehicle system or from an optional power pack. The guide wheel unit is mounted onto the vehicle frame. When the guide wheels are in the "highway" position, the weight of the guide wheel unit is carried on the vehicle frame, above the springs. Load bearing guide wheels assemblies guide the vehicle during on track operation. The guide wheel unit is designed to extend under the vehicle's front suspension, when in the "rail" position and lift the front of the vehicle, raising the front tires above the rails to ensure that the tires do not come into contact with the rails while the vehicle is propelling through crossings, switches, etc. The guide wheel unit utilizes the vehicle's suspension to support the vehicle front load when on track. A steering lock is used during on track operation. The steering lock holds the vehicle's steering wheel in place to ensure the vehicle's front tires remain straight.

The vehicle's rear inner dual wheels are used for propulsion on the track. On track braking is provided by the vehicle's rear brakes, the front guide wheel unit's brakes and the rear guide wheel unit's brakes, if so equipped. Since the guide wheel unit brakes are air actuated, the vehicle on which the guide wheel equipment is mounted should be equipped with air brakes. If not, an electric / air system is available to provide air for the guide wheel unit brakes.

1.3 Vehicle Orientation

Front - rear and left - right are determined from the vehicle operator's seat.

1.4 Serial Numbers

1

When this bulletin is received, complete the following record from the serial number tag on the guide wheel unit. Always provide these factory serial numbers when calling or writing about the unit. The serial number tag is located on the frame assembly of the unit.

FIGURE 1-1
GUIDE WHEEL UNIT SERIAL NUMBER TAG

HTT Harsco Track Technologies a harsco company™		PATENT NUMBER <input type="text"/>
WHEN ORDERING PARTS FOR THIS ACCESSORY ALWAYS GIVE THE FOLLOWING INFORMATION		
Fairmont ™ HY-RAIL® GUIDE WHEEL EQUIPMENT		
SERIAL NUMBER <input type="text"/>	SYMBOL <input type="text"/>	MODEL NUMBER <input type="text"/>
FAIRMONT, MN. 56031 U.S.A.		
52400K		

1.5 Specifications

1.5.1 Vehicle

See the Harsco Track Technologies HY-RAIL® Vehicle Specifications Manual for vehicle specifications. For information regarding special applications not listed in the Harsco Track Technologies Vehicle Specifications Manual, contact Harsco Track Technologies, Harsco Corporation, Fairmont, Minnesota.

1.5.2 Guide Wheel Unit

Track Gauge	56-1/2 in	(1435 mm)
Guide Wheels - Flange Diameter	18 in	(457 mm)
- Tread Diameter	16 in	(406 mm)
Weight	1,100 lbs	(500 kg)
Maximum Load Capacity (with vehicle at curb weight)	20,000 lbs	(9,072 kg)
Maximum Load Per Guide Wheel (with vehicle at curb weight)	10,000 lbs	(4,536 kg)
Hydraulic Operating Pressure	2,800 PSI	(193 bar)

**SECTION 2 - OPERATION
TABLE OF CONTENTS**

2.1 Speedometer 2 - 3

2.2 Preparing Vehicle For Operation 2 - 3

2.3 Preparing Guide Wheel Equipment For Operation 2 - 4

2.4 Misalignment Indicators 2 - 4

2.5 Placing Vehicle On Track 2 - 5

2.5.1 Lower Front Guide Wheels 2 - 6

2.5.2 Rail Brake Control 2 - 7

2.5.3 Steering Locks 2 - 8

2.6 Guide Wheel Load On Track 2 - 9

2.6.1 Checking Front Guide Wheel Load On Track 2 - 10

2.6.2 Checking Vehicle Tire Clearance Above Rails 2 - 10

2.7 Propelling On Track 2 - 12

2.8 Braking On Track 2 - 13

2.9 Vehicles Equipped With Crane Or Aerial Lift Device 2 - 13

2.10 Removing Vehicle From Track 2 - 14

2.10.1 Raise Front Guide Wheels 2 - 15

2.10.2 Steering Locks 2 - 15

2.11 Highway Operation 2 - 16

2.12 Towing Trailer / Equipment With Vehicle On Track 2 - 17

2.13 Towing Trailer / Equipment With Vehicle On Road 2 - 20

2.14 Towing Disabled Vehicle On Track 2 - 23

2.15 Towing Disabled Vehicle On Road 2 - 26

2.1 Speedometer



- **WHEN WHEEL/TIRE MODIFICATIONS ARE APPLIED, CHECK AND CHANGE SPEEDOMETER DRIVE RATIO IF NECESSARY. THE SPEEDOMETER DRIVE RATIO WILL INFLUENCE THE OPERATION OF THE VEHICLE'S ANTI-LOCK BRAKE SYSTEMS, ELECTRONICALLY CONTROLLED TRANSMISSION SHIFT TIMING AND SPEEDOMETER DISPLAY OF THE TRUE VEHICLE SPEED. FAILURE TO MAINTAIN CORRECT SPEEDOMETER DRIVE RATIO COULD RESULT IN SEVERE BODILY INJURY.**

2

Some vehicles require special larger diameter wheels and/or wheel spacers to properly space the vehicle tires for on track operation. Use of these wheel modifications may effect the speedometer drive ratio calibration. The speedometer drive ratio will influence the operation of the vehicle's anti-lock brake systems, electronically controlled transmission shift timing and speedometer display of the true vehicle speed. The vehicle speedometer must be re-calibrated when wheel modifications are applied to the vehicle. See the vehicle manufacturer or dealer for speedometer calibration information.

2.2 Preparing Vehicle for Operation

Be sure the vehicle is in operating condition by checking the following:

- a. Engine oil level.
- b. Radiator fluid level.
- c. Fuel tank level.
- d. Hydraulic reservoir oil level.
- e. Brakes work properly.
- f. Parking brake works properly.
- g. Head, brake and signal lights work properly.
- h. Tires properly inflated to the manufacturer's recommended maximum pressure printed on the sidewall of the tires, or the wheel manufacturer's recommended maximum pressure stamped on the wheel, whichever is lower.
- i. Vehicle wheels: Lug nuts / bolts tightened to the proper torque, inspect vehicle wheels, lug bolts and lug nuts for wear or damage. For vehicle wheel, lug bolt and lug nut inspection information refer to the USER'S GUIDE TO WHEELS AND RIMS produced by THE MAINTENANCE COUNCIL. To obtain this guide, contact:

THE MAINTENANCE COUNCIL
AMERICAN TRUCKING ASSOCIATION
2200 MILL ROAD
ALEXANDRIA, VA. 22314
Phone: (703) 838-1763

- j. Any other normal maintenance requirements.

2.3 Preparing Guide Wheel Equipment For Operation

Be sure the guide wheel equipment is in operating condition by checking the following:

- a. Air and hydraulic hoses and fittings for damage, wear or leaks.
- b. Overall for damaged or worn parts.
- c. Properly lubricated at the recommended operating mileage intervals.
- d. Brakes work properly.
- e. Hydraulic pressure properly adjusted.

2

2.4 Misalignment Indicators



■ **BEFORE OPERATING A VEHICLE WITH NEWLY INSTALLED GUIDE WHEEL EQUIPMENT ON TRACK, VERIFY THAT THE GUIDE WHEEL EQUIPMENT ALIGNMENT PROCEDURE HAS BEEN COMPLETED. CHECK AND CORRECT ALIGNMENT PROMPTLY IF MISALIGNMENT IS INDICATED. MISALIGNMENT OF GUIDE WHEEL EQUIPMENT COULD RESULT IN DERAILMENT OF VEHICLE AND SEVERE BODILY INJURY.**

The following conditions may indicate that minor adjustments to the guide wheel equipment alignment are necessary. If any of these conditions occur during operation, perform the Track Test, see Adjustment Section - Vehicle Track Test and/or complete the Alignment Procedure, see Adjustment - Guide Wheel Equipment Alignment Procedure.

1. Excessive flange or tread wear on any of the rail guide wheels.
2. Vehicle pulls noticeably to the left or the right during on track operation.
3. Vibration felt throughout the vehicle at various speeds during on track operation.

2.5 Placing Vehicle On Track



- PLACE VEHICLE AUTOMATIC TRANSMISSION IN "PARK" OR MANUAL TRANSMISSION IN "NEUTRAL". APPLY THE PARKING BRAKE.
- UNDERSTAND EQUIPMENT OPERATION AND BE AWARE OF ALL PINCH POINTS BEFORE OPERATING OR MAKING ADJUSTMENTS TO GUIDE WHEEL EQUIPMENT.
- BEFORE PROPELLING VEHICLE ON THE TRACK, MAKE SURE:
 - FRONT AND REAR GUIDE WHEELS ARE LOWERED AND LOCKED IN RAIL POSITION, AND SECURED WITH LOCK PIN.
 - ALL RAIL GUIDE WHEEL FLANGES ARE ENGAGED ON INSIDE RAIL.
 - VEHICLE FRONT TIRES ARE A MINIMUM OF 1-1/2" (38 mm) ABOVE THE RAIL.
 - STEERING WHEEL LOCK IS ENGAGED.
 - BRAKE CONTROL VALVE IS IN THE "ON" POSITION AND GUIDE WHEEL BRAKE EQUIPMENT IS FUNCTIONAL.

FAILURE TO HEED THESE WARNINGS COULD RESULT IN DERAILMENT OF VEHICLE AND SEVERE BODILY INJURY.



- WHEN USING VEHICLE MECHANICAL PTO HYDRAULIC PUMP TO LOWER GUIDE WHEEL EQUIPMENT, DO NOT EXCEED HYDRAULIC SYSTEM FLOW OF 5 TO 8 GPM. EXCESSIVE FLOW COULD DAMAGE HYDRAULIC SYSTEM COMPONENTS
- OBSERVE AND FOLLOW ALL RAILROAD SAFETY RULES AND REGULATIONS.
- IF THE VEHICLE IS EQUIPPED WITH A STROBE LIGHT (BEACON) AND RAILROAD RULES AND REGULATIONS REQUIRE ITS USE, THE STROBE LIGHT (BEACON) MUST BE ILLUMINATED WHEN PLACING THE VEHICLE ON TRACK AND WHEN OPERATING THE VEHICLE ON TRACK.

FAILURE TO HEED THESE PRECAUTIONS COULD RESULT IN BODILY INJURY AND/OR PROPERTY DAMAGE.

2.5 Placing Vehicle On Track

1. Ensure that highway vehicles are not approaching the grade crossing while placing the vehicle on track. Flag the crossing per railroad rules and regulations to ensure safety.
2. At a road crossing, drive the vehicle about 25 feet (7.6 m) past the track. Back the vehicle onto the rails so that the rear vehicle wheels are centered on the rails. On vehicles with dual rear wheels, the inner dual wheels must be centered on the rails. It may be necessary to move the vehicle back and forth several times to get the wheels centered on the rail properly.
3. Place the vehicle automatic transmission in "PARK" or manual transmission in "NEUTRAL". Apply the parking brake.
4. Engage the mechanical PTO hydraulic pump or start the auxiliary hydraulic power source. If the vehicle is equipped with an auxiliary control valve, place the valve in the proper position to direct hydraulic oil flow to the guide wheel equipment.
5. Lower and lock the rear guide wheels first. The rear guide wheels should be lowered first so the front tires of the vehicle can be maneuvered to align the front guide wheels with the rails. See the Operator's Service And Parts Manual provided with the rear guide wheel unit for the procedure to lower the rear guide wheels.

2.5.1 Lowering Front Guide Wheels - See Figure 2-1

1. Push Control Valve Handle (1) down to disengage the locks. If the locks do not readily disengage, move Control Valve Handle (2) slightly to raise or lower the guide wheels to release any tension on the lock pins. Make sure the locks are disengaged.
2. Pull control valve handle (2) up to lower the guide wheels. Make sure the guide wheels are fully lowered and the rail guide wheel flanges are engaged on the inside of the rails. Release the Control Valve Handle.
3. Make sure the vehicle front wheels are raised and suspended at least 1-1/2 inch (38 mm) above the top of the rails.
4. Disengage the mechanical PTO hydraulic pump or stop the auxiliary hydraulic power source. If the vehicle is equipped with an auxiliary control valve, place the valve in the proper position to shut off hydraulic oil flow to the guide wheel equipment.

2.5 Placing Vehicle On Track

2.5.1 Lowering Front Guide Wheels

FIGURE 2-1
LOWERING FRONT GUIDE WHEELS

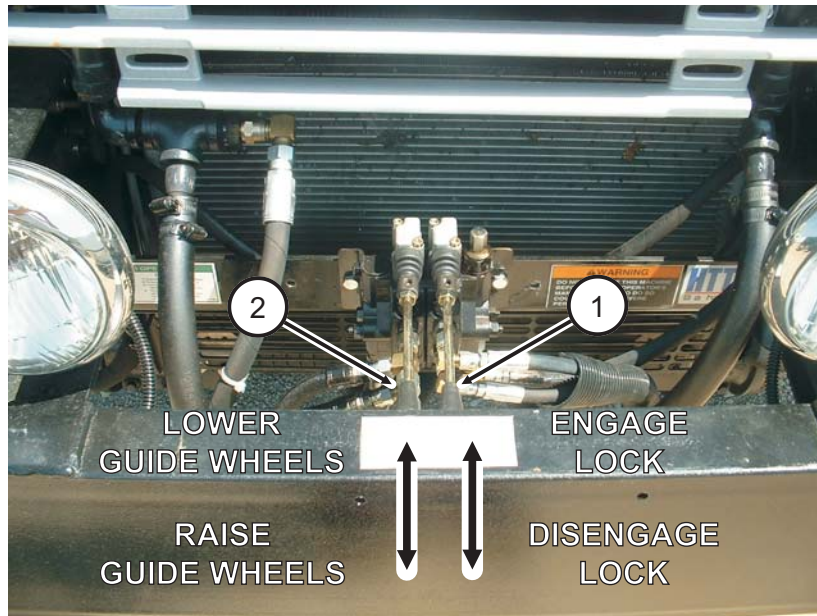

04-227

2.5.2 Rail Brake Control

If so equipped, move the Rail Wheel Brake Control Valve to the ON position to activate the guide wheel equipment brakes whenever the vehicle is on track. The vehicle brake pedal will actuate the vehicle brakes and the guide wheel equipment brakes simultaneously.

2.5 Placing Vehicle On Track

2.5.3 Steering Locks - See Figures 2-2, 2-3, 2-4 and 2-5

Set the vehicle front wheels straight ahead and secure the steering wheel in that position by engaging the steering lock on the steering column. Steering locks may vary from vehicle to vehicle but will operate similarly.

2

Note: Do not place your hands or any pressure on the steering wheel after the steering lock is engaged.

FIGURE 2-2
DEAD BOLT TYPE
STEERING LOCK DISENGAGED

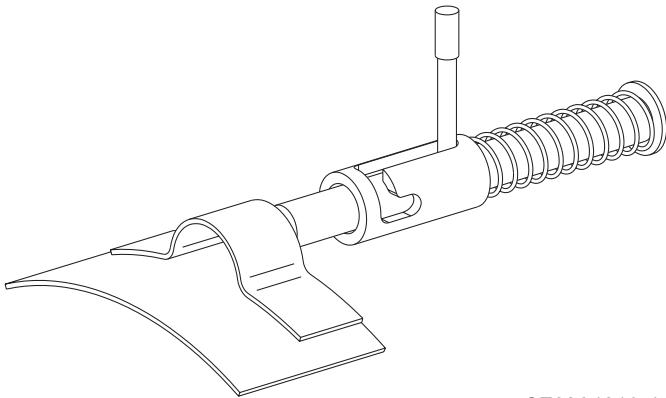

SE99A191A-1

FIGURE 2-3
DEAD BOLT TYPE
STEERING LOCK ENGAGED

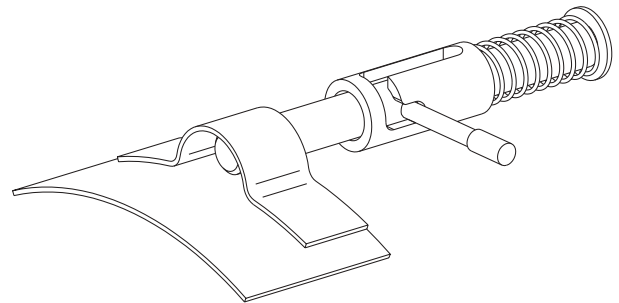

SE99A192A-1

FIGURE 2-4
LOCK TAB TYPE
STEERING LOCK DISENGAGED

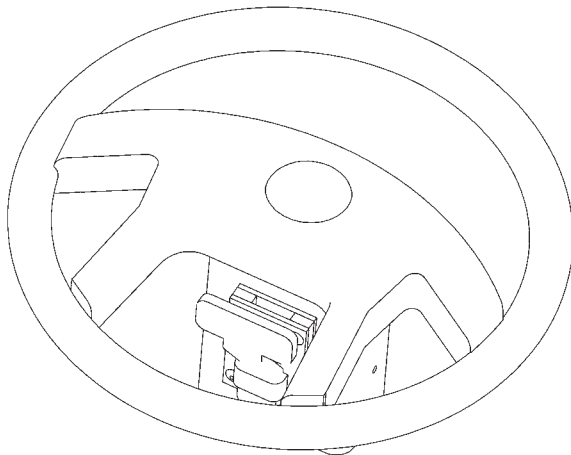
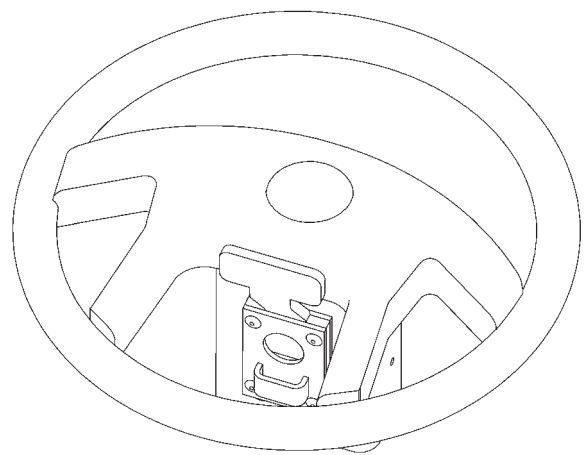

FIGURE 2-5
LOCK TAB TYPE
STEERING LOCK ENGAGED



2.6 Guide Wheel Load On Track



- **IMPROPER LOADING OF GUIDE WHEEL EQUIPMENT CAN CAUSE DERAILMENT OF VEHICLE.**
- **ALWAYS CHECK THE GUIDE WHEEL LOAD BEFORE OPERATING THE VEHICLE ON TRACK.**
- **NEVER OPERATE THE VEHICLE ON TRACK IF LOAD EXCEEDS THE MAXIMUM RATED LOAD OF THE FRONT AND/OR REAR GUIDE WHEEL UNITS. THE MAXIMUM LOAD ON THE FRONT GUIDE WHEEL UNIT IS 20,000 LBS (9,072kg) OR 10,000 LBS (4,536 kg) MAXIMUM PER GUIDE WHEEL.**
- **NEVER OPERATE THE VEHICLE ON TRACK IF CLEARANCE BETWEEN VEHICLE FRONT TIRES AND RAIL IS LESS THAN 1-1/2" (38 mm).**
- **MISUSE OF THE WHEEL LOAD JACK MAY CAUSE THE GAUGE TO EXPLODE. READ ANSI B40.1 AND APPARATUS INSTALLATION/ OPERATION INSTRUCTIONS BEFORE USE.**

FAILURE TO HEED THESE WARNINGS COULD RESULT IN DERAILMENT OF VEHICLE AND/OR SEVERE BODILY INJURY.



- **APPLY PARKING BRAKE AND STOP ENGINE BEFORE USING WHEEL LOAD JACK.**
- **DO NOT USE THE WHEEL LOAD JACK TO LIFT VEHICLE. EXCESSIVE WEIGHT MAY CAUSE JACK TO FAIL.**
- **REPLACE WHEEL LOAD JACK GAUGE IF LOAD LIMIT DECAL IS MISSING OR UNREADABLE.**

FAILURE TO HEED THESE CAUTIONS COULD RESULT IN BODILY INJURY AND/OR PROPERTY DAMAGE.

Whenever the vehicle is loaded or additional load is added to the existing vehicle load on track, check the load on the front guide wheel unit guide wheels using the 159510 wheel load jack.

The 159510 wheel load jack is designed to be used to check the guide wheel load on the HR4500, HR4000 and the HR3000 front guide wheel units. When checking the guide wheel load on the HR4000 Series C1, always use the scale on the gauge marked "HR4000".

2.6 Guide Wheel Load On Track

2.6.1 Checking Front Guide Wheel Load - See Figures 2-6 and 2-7

1. Position the vehicle on track so the front guide wheel unit axle is located directly over a tie.
2. Apply the parking brake. Stop the engine.
3. Place the wheel load jack under the axle on the tie and next to the rail.
4. Jack the guide wheel unit front axle up until the tread on the front guide wheel clears the top of the rail. The gauge reading indicates the load on the front guide wheel. The indicated front guide wheel load must not exceed the load limit printed on the wheel load jack gauge. The wheel load jack will not hold the gauge reading for an extended period of time. The gauge readings must be taken as the jack is slowly operated.

Note: An easy way to tell when the guide wheel just clears the top of the rail is to jack the guide wheel up approximately 1/4" (6.4 mm) above the top of the rail. Place a piece of paper between the rail and the guide wheel. Lower the guide wheel onto the paper. Slowly jack the guide wheel up while applying a steady pulling force on the paper until it can be pulled out. Note the gauge reading when the paper can be pulled out.

5. The maximum load on the front guide wheel unit is 20,000 lbs (9,072 kg) or 10,000 lbs (4,536 kg) maximum per guide wheel. The guide wheel load must also be equal or within ± 100 lbs (45 kg) on the both the left and right ends of the guide wheel unit.

If the indicated front guide wheel load does not exceed the maximum load capacity, the load on the front guide wheel is acceptable.

If the indicated front guide wheel load does exceed the maximum load capacity, the load must be redistributed or some of the load removed. Never operate the vehicle on track if the load on the front guide wheel exceeds the maximum load capacity of 20,000 lbs (9,072 kg) or 10,000 lbs (4,536 kg) maximum per guide wheel.

6. Repeat Steps 3 through 5 to check the load on the opposite front guide wheel.
7. When finished checking the front guide wheel load, remove the wheel load jack and store it in the vehicle cab.
8. If the load limit decal is missing or unreadable on the wheel load jack gauge, replace the gauge as an assembly with the decal already installed (order HTT part no. 159512).

Whenever the vehicle is loaded or additional load is added to the existing vehicle load on track, check the load on the front guide wheels. See the Operator's Service And Parts Manual provided with the rear guide wheel unit for the procedure for checking the load on the rear guide wheel unit.

2.6 Guide Wheel Load On Track

FIGURE 2-6
WHEEL LOAD JACK PLACEMENT UNDER
FRONT GUIDE WHEEL UNIT AXLE

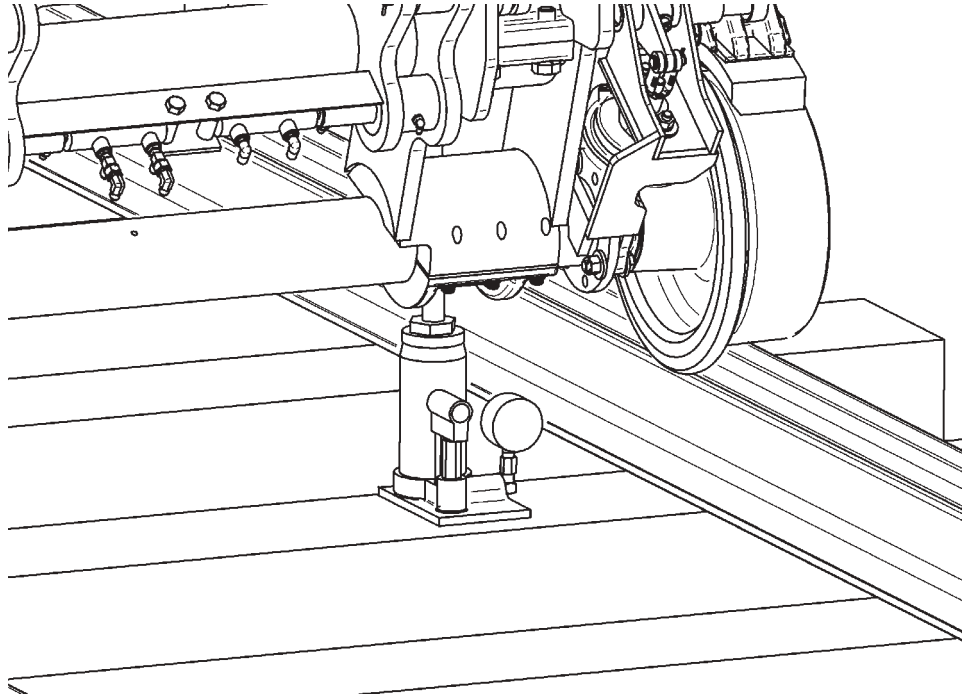

2

FIGURE 2-7
WHEEL LOAD JACK GAUGE FACE

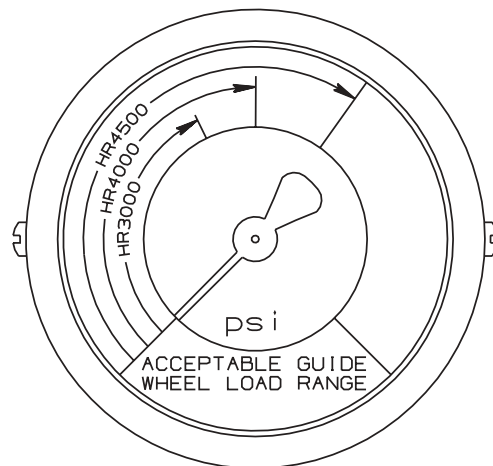

SE159521A-1

2.6.2 Check Vehicle Front Tire Clearance Above Rail

If the vehicle's front tire clearance above the rail is less than 1-1/2" (38 mm) see the Adjustment Section - Vehicle Front Wheel Clearance. Never operate the vehicle on track when the front tire clearance above the rail is less than 1-1/2" (38 mm).

2.7 Propelling On Track



2

- **IMPROPER LOADING OF HY-RAIL® EQUIPPED VEHICLE CAN CAUSE DERAILMENT OF VEHICLE.**
- **ALWAYS CHECK GUIDE WHEEL LOAD BEFORE OPERATING THE VEHICLE ON TRACK.**
- **NEVER OPERATE VEHICLE ON TRACK IF LOAD EXCEEDS MAXIMUM RATED LOAD OF FRONT AND/OR REAR GUIDE WHEEL UNITS.**
- **NEVER OPERATE VEHICLE ON TRACK IF CLEARANCE BETWEEN VEHICLE FRONT TIRE AND RAIL IS LESS THAN 1-1/2" (38 mm).**

FAILURE TO HEED THESE WARNINGS COULD RESULT IN DERAILMENT OF VEHICLE AND/OR SEVERE BODILY INJURY.



- **BEFORE OR WHEN PROPELLING ON TRACK:**
 - **OBSERVE AND FOLLOW ALL RAILROAD SAFETY RULES AND REGULATIONS.**
 - **OPERATOR MUST LOOK IN ALL DIRECTIONS FOR PERSONS OR OBJECTS ON OR ADJACENT TO THE TRACK.**
 - **DO NOT ACCELERATE SUDDENLY. TRACTION IS REDUCED ON TRACK, SPINNING VEHICLE TIRES COULD DAMAGE THEM.**
 - **DO NOT EXCEED 25 MPH (40 km/h) WHEN OPERATING VEHICLE ON TRACK. RAILROAD RULES GOVERNING SPEEDS SHOULD BE OBSERVED AT ALL TIMES. REDUCE SPEED WHEN PROPELLING VEHICLE THROUGH SWITCHES, ROAD CROSSINGS, BRANCH LINES AND ANY SPECIAL TRACK WORKS. OPERATING VEHICLE AT UNSAFE SPEEDS COULD RESULT IN DERAILMENT OF THE VEHICLE.**
 - **STEERING LOCK MUST BE ENGAGED AT ALL TIMES WHEN OPERATING VEHICLE ON TRACK.**
 - **IF THE VEHICLE IS EQUIPPED WITH A STROBE LIGHT (BEACON) AND RAILROAD RULES AND REGULATIONS REQUIRE ITS USE, THE STROBE LIGHT (BEACON) MUST BE ILLUMINATED WHEN OPERATING THE VEHICLE ON TRACK.**

FAILURE TO HEED THESE PRECAUTIONS COULD RESULT IN BODILY INJURY AND/OR PROPERTY DAMAGE.

Vehicles equipped with the HR4000 Series C1 HY-RAIL® Guide Wheel Equipment use the vehicle propulsion system to propel on track. Do not accelerate suddenly. Traction is reduced on track. Spinning the vehicle tires could damage them.

2.8 Braking On Track



- PERSONS WHO OPERATE THE VEHICLE MUST BE FAMILIAR WITH TRACK AND WEATHER CONDITIONS THAT MAY AFFECT STOPPING DISTANCE. BE ALERT TO THESE CONDITIONS AND ALLOW ADEQUATE STOPPING DISTANCE.
- BE PREPARED TO BRAKE AT ALL HIGHWAY CROSSINGS. THIS VEHICLE MAY NOT OPERATE TRACK SIGNAL CIRCUITS, AND ONCOMING VEHICLES OR PEDESTRIANS MAY NOT YIELD THE RIGHT OF WAY.
- RAIL WHEEL BRAKE CONTROL VALVE MUST BE IN THE "ON" POSITION WHENEVER VEHICLE IS ON TRACK.

FAILURE TO HEED THESE PRECAUTIONS COULD RESULT IN BODILY INJURY AND/OR PROPERTY DAMAGE.

The HR4000 Series C1 HY-RAIL® Guide Wheel Equipment may be equipped with brakes. If the guide wheel unit is equipped with brakes, the vehicle uses a combination of the front guide wheel unit brakes and the vehicle's rear axle brake system for braking on track. The front guide wheel unit brakes will apply simultaneously when the vehicle brakes are applied. Stopping distance is greater on track than on typical road surfaces. Apply the brakes gradually to avoid sliding the vehicle tires and rail guide wheels.

2.9 Vehicles Equipped With Crane Or Aerial Lift Device



- WHEN OPERATING CRANE, AERIAL LIFT DEVICE, ETC., WHILE THE VEHICLE'S GUIDE WHEELS ARE ON THE RAILS, DO NOT OVERLOAD THE GUIDE WHEEL EQUIPMENT OR EXCEED THE CAPACITY OF ANY OF THE EQUIPMENT BEING USED.
- THE UNIT SHOULD BE EQUIPPED WITH OUTRIGGERS TO HELP PREVENT ACCIDENTS AND THE POSSIBILITY OF DAMAGE TO THE GUIDE WHEEL EQUIPMENT. WHEN USING THE EQUIPMENT TO TRANSFER ANY LOAD, SET THE OUTRIGGERS ON A STABLE BASE TO PREVENT SETTLING OF THE OUTRIGGERS AND SHIFTING OF THE VEHICLE.
- IF OPERATING CONDITIONS REQUIRE LIFTING A LOAD WITH THE CRANE WHILE ON RAIL, BUT WITHOUT THE OUTRIGGERS BEING USED, THE LOAD APPLIED BY LIFTING WITH THE CRANE MUST NOT OVERLOAD ANY COMPONENT OF THE GUIDE WHEEL EQUIPMENT.
- CAREFULLY READ THE CRANE OR AERIAL LIFT DEVICE OPERATOR'S MANUAL FOR THE SAFE USE AND EFFICIENT OPERATION OF THE EQUIPMENT.

FAILURE TO HEED THESE WARNINGS COULD CAUSE DERAILMENT OF THE VEHICLE RESULTING IN SEVERE BODILY INJURY AND/OR DEATH.

2.10 Removing Vehicle From Track



2

- PLACE VEHICLE AUTOMATIC TRANSMISSION IN "PARK" OR MANUAL TRANSMISSION IN "NEUTRAL". APPLY THE PARKING BRAKE.
- UNDERSTAND EQUIPMENT OPERATION AND BE AWARE OF ALL PINCH POINTS BEFORE OPERATING OR MAKING ADJUSTMENTS TO GUIDE WHEEL EQUIPMENT.
- BEFORE PROPELLING VEHICLE OFF TRACK, MAKE SURE:
 - FRONT AND REAR GUIDE WHEELS ARE RAISED, LOCKED IN THE HIGHWAY POSITION, AND SECURED WITH THE LOCK PINS.
 - STEERING WHEEL LOCK IS DISENGAGED.

FAILURE TO HEED THESE WARNINGS COULD RESULT IN SEVERE BODILY INJURY.



- WHEN USING VEHICLE MECHANICAL PTO HYDRAULIC PUMP TO RAISE GUIDE WHEEL EQUIPMENT, DO NOT EXCEED HYDRAULIC SYSTEM FLOW OF 5 TO 8 GPM. EXCESSIVE FLOW COULD DAMAGE HYDRAULIC SYSTEM COMPONENTS
- OBSERVE AND FOLLOW ALL RAILROAD SAFETY RULES AND REGULATIONS.
- IF THE VEHICLE IS EQUIPPED WITH A STROBE LIGHT (BEACON) AND RAILROAD RULES AND REGULATIONS REQUIRE ITS USE, THE STROBE LIGHT (BEACON) MUST BE ILLUMINATED WHEN OPERATING AND REMOVING THE VEHICLE FROM TRACK.

FAILURE TO HEED THESE PRECAUTIONS COULD RESULT IN BODILY INJURY AND/OR PROPERTY DAMAGE.

1. Ensure that highway vehicles are not approaching the grade crossing while placing the vehicle on track. Flag the crossing per railroad rules and regulations to ensure safety.
2. Approach the crossing and stop with the vehicle front wheels on the crossing.
3. Place the vehicle automatic transmission in "PARK" or manual transmission in "NEUTRAL". Apply the parking brake.
4. If so equipped, move the Rail Wheel Brake control valve to the OFF position, whenever the vehicle is removed from the track for highway use.
5. Engage the mechanical PTO hydraulic pump or start the auxiliary hydraulic power source. If the vehicle is equipped with an auxiliary control valve, place the valve in the proper position to direct hydraulic oil flow to the guide wheel equipment.

2.10 Removing Vehicle From Track

2.10.1 Raising Front Guide Wheels - See Figure 2-8

1. Push control valve handle (2) down to raise the guide wheels. Make sure the guide wheels are fully raised. Release the Control Valve Handle.
2. Pull Control Valve Handle (1) up to engage the locks. If the locks do not readily engage, move Control Valve Handle (2) slightly to raise or lower the guide wheels to allow the lock pins to engage. Make sure the locks are engaged.
3. Raise and lock the rear guide wheels in the "highway" position. See the Operator's Service And Parts Manual provided with the rear guide wheel unit for the procedure to raise the rear guide wheels.
4. Disengage the mechanical PTO hydraulic pump or stop the auxiliary hydraulic power source. If the vehicle is equipped with an auxiliary control valve, place the valve in the proper position to shut off hydraulic oil flow to the guide wheel equipment.

FIGURE 2-8
RAISING FRONT GUIDE WHEELS

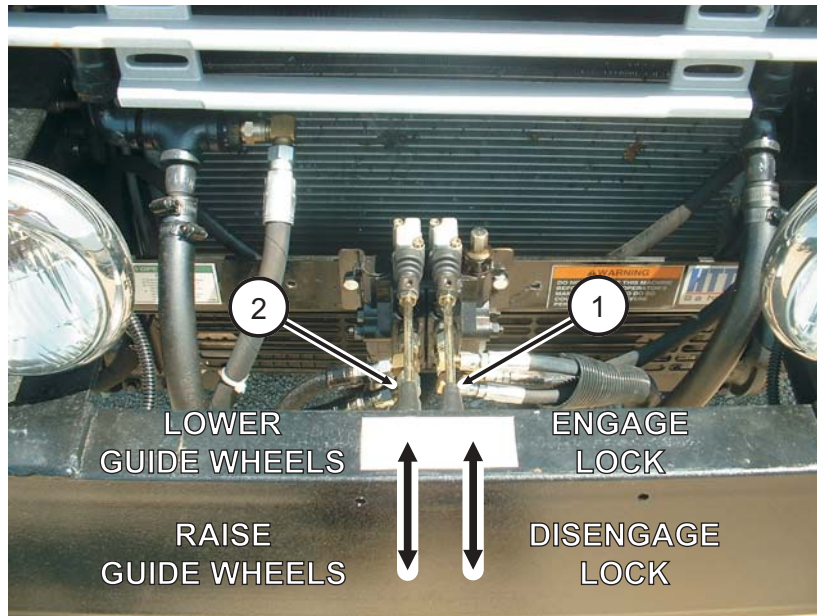

04-227

2.10.2 Steering Locks - See Figures 2-2, 2-3, 2-4 and 2-5

1. Disengage the vehicle steering lock located on the steering column. Steering locks may vary from vehicle to vehicle but will operate similarly.

2.11 Highway Operation



2

- THIS MULTIPURPOSE VEHICLE HAS SPECIAL DESIGN AND EQUIPMENT FEATURES FOR OFF-ROAD USE. IT HANDLES DIFFERENTLY FROM AN ORDINARY PASSENGER CAR IN DRIVING CONDITIONS WHICH MAY OCCUR ON STREETS, HIGHWAYS AND OFF-ROAD. WEIGHT AND LOCATION OF AVAILABLE PAYLOAD MAY ALSO AFFECT THE HANDLING OF THIS VEHICLE. DRIVE WITH CARE AND WEAR SAFETY BELTS AT ALL TIMES. READ VEHICLE OWNER'S MANUAL FOR ADDITIONAL PRECAUTIONS.

2.12 Towing Trailer / Equipment With Vehicle On Track



- VEHICLE USED FOR TOWING MUST BE RATED BY VEHICLE MANUFACTURER FOR WEIGHT OF TRAILER / EQUIPMENT TO BE TOWED. DO NOT EXCEED VEHICLE MANUFACTURER'S MAXIMUM RATED TOWING CAPACITY.
- TOWING VEHICLE MUST WEIGH AS MUCH OR MORE THAN TRAILER / EQUIPMENT BEING TOWED.
- VEHICLE USED FOR TOWING MUST HAVE AN ADEQUATE BRAKE SYSTEM TO SAFELY DECELERATE AND STOP TOWING VEHICLE AND TRAILER / EQUIPMENT BEING TOWED.
- TOWING TRAILER / EQUIPMENT LENGTHENS STOPPING DISTANCES. ALLOW ADEQUATE DISTANCE FOR STOPPING. ANTICIPATE STOPS SO YOU CAN BRAKE GRADUALLY.
- STOPPING DISTANCE IS GREATER ON TRACK THAN ON TYPICAL ROAD SURFACES. APPLY BRAKES GRADUALLY TO AVOID SLIDING VEHICLE TIRES AND GUIDE WHEELS.
- TOW TRAILER / EQUIPMENT AT A REASONABLE SPEED (20 MPH MAXIMUM) TAKING INTO ACCOUNT TRACK CONDITIONS, TRACK GRADE, WEATHER, VISIBILITY AND STOPPING DISTANCE TO ASSURE SAFE OPERATION. RAILROAD RULES GOVERNING SPEEDS AND RIGHT OF WAY SHOULD BE OBSERVED AT ALL TIMES.
- TRAILER / EQUIPMENT BEING TOWED MUST BE IN A SAFE, USABLE CONDITION TO BE TOWED.
- MAKE SURE THAT VEHICLE'S:
 - FRONT AND REAR GUIDE WHEEL ARE LOWERED AND LOCKED IN THE RAIL POSITION.
 - ALL GUIDE WHEEL FLANGES ARE ENGAGED ON INSIDE OF RAILS.
 - FRONT TIRES ARE A MINIMUM OF 1-1/2" (38 mm) ABOVE RAIL.
 - VEHICLE STEERING WHEEL LOCK ENGAGED WITH FRONT WHEELS STRAIGHT AHEAD.

FAILURE TO HEED THESE WARNINGS COULD RESULT IN SEVERE BODILY INJURY.

2.12 Towing Trailer / Equipment With Vehicle On Track



2

- CAREFULLY AND THOROUGHLY PREPARE VEHICLE FOR TOWING, MAKING SURE TO USE THE RIGHT TOWING EQUIPMENT AND TO ATTACH IT PROPERLY.
- TOWING EQUIPMENT (HITCHES, TOW BARS, ETC.) MUST BE ATTACHED TO VEHICLE FRAME. DO NOT MOUNT OR ATTACH TOWING EQUIPMENT TO VEHICLE'S GUIDE WHEEL EQUIPMENT.
- TOWING EQUIPMENT (HITCHES, TOW BARS, ETC.) MUST HAVE A RATED TOWING CAPACITY EQUAL TO OR GREATER THAN WEIGHT OF TRAILER / EQUIPMENT BEING TOWED.
- USE A RIGID TYPE TOW BAR WITH SAFETY LOCKING COUPLERS. DO NOT USE CHAIN, WIRE ROPE ETC.
- OBSERVE AND FOLLOW ALL RAILROAD SAFETY RULES AND REGULATIONS.
- DO NOT ACCELERATE SUDDENLY. TRACTION IS REDUCED ON RAIL, SPINNING VEHICLE TIRES COULD DAMAGE THEM.
- ALWAYS CHOCK TRAILER WHEELS BEFORE UNHOOKING TRAILER FROM TOWING VEHICLE.

FAILURE TO HEED THESE PRECAUTIONS COULD RESULT IN BODILY INJURY AND/OR PROPERTY DAMAGE.

2.12 Towing Trailer / Equipment With Vehicle On Track

1. See your vehicle's operators manual for towing information.
2. Use the vehicle manufacturer's recommendations to determine the maximum weight the towing vehicle can tow. Do not exceed vehicle manufacturer's maximum rated towing capacity.
3. The towing vehicle must have an adequate brake system to safely decelerate and stop the towing vehicle and the trailer / equipment being towed. The towing vehicle must weigh as much or more than the trailer / equipment being towed.
4. Make sure that the vehicle's:
 - a. Front and rear guide wheels are lowered and locked in the rail position.
 - b. All guide wheel flanges are engaged on the inside of the rails.
 - c. Front tires are a minimum of 1-1/2" (38 mm) above the rail.
 - d. Vehicle front wheels are set straight ahead and the steering wheel lock is engaged on the steering column.
5. Make sure the towing vehicle and the trailer / equipment are in good working condition (tires, brakes, lights, etc.) and that current maintenance has been performed on the vehicle and trailer / equipment.
6. The towing equipment (hitches, tow bars, etc.) on the towing vehicle must have a rating equal to or greater than the weight of the trailer / equipment being towed.
7. The towing equipment (hitches, tow bars, etc.) must be attached to the towing vehicle frame. Do not mount or attach the towing equipment to the vehicle's guide wheel equipment.
8. Observe and follow all railroad safety rules and regulations.
9. Do not accelerate suddenly. Traction is reduced on rail. Spinning the vehicle tires could damage them.
10. Stopping distance is greater on rail than on typical road surfaces. Apply the vehicle brakes gradually to avoid sliding the vehicle tires and the guide wheels. Towing trailer / equipment lengthens stopping distances. Allow adequate distance for stopping. Anticipate stops so that you can brake gradually.
11. Tow the trailer / equipment on the track at a reasonable speed (20 MPH maximum) taking into account track conditions, track grade, weather, visibility and stopping distance to assure safe operation. Railroad rules and regulations governing speed limits and right of way should be observed at all times.
12. Always chock the trailer wheels before unhooking the trailer from the towing vehicle.

2.13 Towing Trailer / Equipment With Vehicle On Road



2

- VEHICLE USED FOR TOWING MUST BE RATED BY VEHICLE MANUFACTURER FOR WEIGHT OF TRAILER / EQUIPMENT TO BE TOWED. DO NOT EXCEED VEHICLE MANUFACTURER'S MAXIMUM RATED TOWING CAPACITY.
- VEHICLE USED FOR TOWING MUST HAVE AN ADEQUATE BRAKE SYSTEM TO SAFELY DECELERATE AND STOP TOWING VEHICLE AND TRAILER / EQUIPMENT BEING TOWED.
- TOWING TRAILER / EQUIPMENT LENGTHENS STOPPING DISTANCES. ALLOW ADEQUATE DISTANCE FOR STOPPING. ANTICIPATE STOPS SO YOU CAN BRAKE GRADUALLY.
- TOW TRAILER / EQUIPMENT AT A REASONABLE SPEED TAKING INTO ACCOUNT ROAD CONDITIONS, ROAD GRADE, WEATHER, VISIBILITY AND STOPPING DISTANCE TO ASSURE SAFE OPERATION. POSTED SPEED LIMITS SHOULD BE OBSERVED AT ALL TIMES.
- TRAILER / EQUIPMENT BEING TOWED MUST BE IN A SAFE, USABLE CONDITION TO BE TOWED.
- MAKE SURE THAT VEHICLE'S:
 - FRONT AND REAR GUIDE WHEELS ARE RAISED AND LOCKED IN HIGHWAY POSITION.
 - VEHICLE STEERING WHEEL LOCK DISENGAGED.

FAILURE TO HEED THESE WARNINGS COULD RESULT IN SEVERE BODILY INJURY.

2.13 Towing Trailer / Equipment With Vehicle On Road



- THIS MULTIPURPOSE VEHICLE HAS SPECIAL DESIGN AND EQUIPMENT FEATURES FOR OFF-ROAD USE. IT HANDLES DIFFERENTLY FROM AN ORDINARY PASSENGER CAR IN DRIVING CONDITIONS WHICH MAY OCCUR ON STREETS, HIGHWAYS AND OFF-ROAD. WEIGHT AND LOCATION OF AVAILABLE PAYLOAD MAY ALSO AFFECT THE HANDLING OF THIS VEHICLE. DRIVE WITH CARE AND WEAR SAFETY BELTS AT ALL TIMES. READ VEHICLE OWNER'S MANUAL FOR ADDITIONAL PRECAUTIONS.
- OBSERVE AND FOLLOW ALL FEDERAL, STATE AND LOCAL DRIVING RULES AND REGULATIONS.
- STATE LAWS MAY REQUIRE TOWING VEHICLE AND TRAILER / EQUIPMENT BEING TOWED TO BE EQUIPPED WITH SPECIAL SAFETY EQUIPMENT (MIRRORS ON BOTH SIDES OF TOWING VEHICLE, TRAILER BRAKES, TRAILER LIGHTS, ETC.).
- CAREFULLY AND THOROUGHLY PREPARE YOUR VEHICLE FOR TOWING, MAKING SURE TO USE THE RIGHT TOWING EQUIPMENT AND TO ATTACH IT PROPERLY.
- TOWING EQUIPMENT (HITCHES, TOW BARS, ETC.) MUST BE ATTACHED TO VEHICLE FRAME. DO NOT MOUNT OR ATTACH TOWING EQUIPMENT TO VEHICLE'S GUIDE WHEEL EQUIPMENT.
- TOWING EQUIPMENT (HITCH, TOW BAR, ETC.) MUST HAVE A RATED TOWING CAPACITY EQUAL TO OR GREATER THAN WEIGHT OF TRAILER / EQUIPMENT BEING TOWED.
- ALWAYS CHOCK TRAILER WHEELS BEFORE UNHOOKING TRAILER FROM TOWING VEHICLE.

FAILURE TO HEED THESE PRECAUTIONS COULD RESULT IN BODILY INJURY AND/OR PROPERTY DAMAGE.

2.13 Towing Trailer / Equipment With Vehicle On Road

1. See your vehicle's operators manual for towing information.
2. Use the vehicle manufacturer's recommendations to determine the maximum weight the towing vehicle can tow. Do not exceed vehicle manufacturer's maximum rated towing capacity.
3. The towing vehicle must have an adequate brake system to safely decelerate and stop the towing vehicle and the trailer / equipment being towed. Towing trailer / equipment lengthens stopping distances. Allow adequate distance for stopping. Anticipate stops so that you can brake gradually.
4. Make sure that the vehicle's:
 - a. Front and rear guide wheels are raised and locked in the highway position.
 - b. Vehicle steering wheel lock is disengaged on the steering column.
5. Make sure the towing vehicle and the trailer / equipment are in good working condition (tires, brakes, lights, etc.) and that current maintenance has been performed on the vehicle and trailer / equipment.
6. The towing equipment (hitches, tow bars, etc.) on the towing vehicle must have a rating equal to or greater than the weight of the trailer / equipment being towed.
7. The towing equipment (hitches, tow bars, etc.) must be attached to the towing vehicle frame. Do not mount or attach the towing equipment to the vehicle's guide wheel equipment.
8. Observe and follow all federal, state and local driving rules, regulations and laws.
9. State laws may require the towing vehicle and/or the trailer / equipment being towed to be equipped with special safety equipment (mirrors on both sides of the towing vehicle, trailer brakes, trailer lights, etc.).
10. Tow the trailer / equipment on the road at a reasonable speed taking into account road conditions, road grade, weather, visibility and stopping distance to assure safe operation. Always observe posted speed limits.
11. Always chock the trailer wheels before unhooking the trailer from the towing vehicle.

2.14 Towing Disabled Vehicle On Track



- TOWING VEHICLE / MACHINE MUST WEIGH AS MUCH OR MORE THAN DISABLED VEHICLE BEING TOWED.
- VEHICLE / MACHINE USED FOR TOWING MUST HAVE AN ADEQUATE BRAKE SYSTEM TO SAFELY DECELERATE AND STOP TOWING VEHICLE / MACHINE AND DISABLED VEHICLE BEING TOWED.
- TOWING DISABLED VEHICLE LENGTHENS STOPPING DISTANCES. ALLOW ADEQUATE DISTANCE FOR STOPPING. ANTICIPATE STOPS SO YOU CAN BRAKE GRADUALLY.
- TOW DISABLED VEHICLE AT A REASONABLE SPEED (10 MPH MAXIMUM) TAKING INTO ACCOUNT TRACK CONDITIONS, TRACK GRADE, WEATHER, VISIBILITY AND STOPPING DISTANCE TO ASSURE SAFE OPERATION. RAILROAD RULES GOVERNING SPEED LIMITS AND RIGHT OF WAY SHOULD BE OBSERVED AT ALL TIMES.
- STOPPING DISTANCE IS GREATER ON TRACK THAN ON TYPICAL ROAD SURFACES. APPLY BRAKES GRADUALLY TO AVOID SLIDING TOWING VEHICLE / MACHINE WHEELS.
- MAKE SURE THAT DISABLED VEHICLE'S:
 - FRONT AND REAR GUIDE WHEELS ARE LOWERED AND LOCKED IN RAIL POSITION.
 - ALL GUIDE WHEEL FLANGES ARE ENGAGED ON INSIDE OF RAILS.
 - FRONT TIRES ARE A MINIMUM OF 1-1/2" (38 mm) ABOVE RAIL.
 - VEHICLE STEERING WHEEL LOCK ENGAGED WITH FRONT WHEELS STRAIGHT AHEAD.

FAILURE TO HEED THESE WARNINGS COULD RESULT IN SEVERE BODILY INJURY.

2.14 Towing Disabled Vehicle On Track



2

- TOW BAR MUST BE ATTACHED TO DISABLED VEHICLE'S FRAME. DO NOT MOUNT OR ATTACH TOW BAR TO DISABLED VEHICLE'S GUIDE WHEEL EQUIPMENT.
- TOW BAR MUST HAVE A RATED TOWING CAPACITY EQUAL TO OR GREATER THAN WEIGHT OF DISABLED VEHICLE BEING TOWED.
- USE A RIGID TYPE TOW BAR WITH SAFETY LOCKING COUPLERS. DO NOT USE CHAIN, WIRE ROPE ETC.
- OBSERVE AND FOLLOW ALL RAILROAD SAFETY RULES AND REGULATIONS.
- DO NOT ACCELERATE SUDDENLY. TRACTION IS REDUCED ON RAIL, SPINNING TOWING VEHICLE / MACHINE WHEELS COULD DAMAGE THEM.
- TOW DISABLED VEHICLE TO NEAREST ROAD CROSSING AND REMOVE FROM TRACK.

FAILURE TO HEED THESE PRECAUTIONS COULD RESULT IN BODILY INJURY AND/OR PROPERTY DAMAGE.

2.14 Towing Disabled Vehicle On Track

1. See your vehicle's operators manual for towing information.
2. The towing vehicle / machine must have an adequate brake system to safely decelerate and stop the towing vehicle / machine and the disabled vehicle being towed. The towing vehicle / machine must weigh as much or more than the disabled vehicle towed.
3. Make sure that the disabled vehicle's:
 - a. Front and rear guide wheels are lowered and locked in the rail position.
 - b. All guide wheel flanges are engaged on the inside of the rails.
 - c. Front tires are a minimum of 1-1/2" (38 mm) above the rail.
 - d. Vehicle front wheels are set straight ahead and the steering wheel lock is engaged on the steering column.
4. Make sure the towing vehicle / machine is in good working condition (tires, brakes, lights, etc.) and that current maintenance has been performed on the vehicle / machine.
5. The towing equipment (hitches, tow bars, etc.) on the towing vehicle / machine must have a rating equal to or greater than the weight of the disabled vehicle being towed.
6. The tow bar must be mounted or attached to the disabled vehicle's frame. Do not mount or attach the tow bar to the disabled vehicle's guide wheel equipment. Use a rigid type tow bar with safety locking couplers.
7. Observe and follow all railroad safety rules and regulations.
8. Do not accelerate suddenly. Traction is reduced on rail. Spinning the towing vehicle tires / machine wheels could damage them.
9. Stopping distance is greater on rail than on typical road surfaces. Apply the towing vehicle / machine brakes gradually to avoid sliding the vehicle tires / machine wheels. Towing disabled vehicle lengthens stopping distances. Allow adequate distance for stopping. Anticipate stops so that you can brake gradually.
10. Tow the disabled vehicle on the track at a reasonable speed (10 MPH maximum) taking into account track conditions, track grade, weather, visibility and stopping distance to assure safe operation. Railroad rules and regulations governing speed limits and right of way should be observed at all times.
11. Tow the disabled vehicle to the nearest road crossing and remove the vehicle from the track.

2.15 Towing Disabled Vehicle On Road



2

- TOW DISABLED VEHICLE PER VEHICLE MANUFACTURER'S TOWING SPECIFICATIONS LISTED IN YOUR VEHICLE'S OPERATORS MANUAL.
- VEHICLE USED FOR TOWING MUST HAVE AN ADEQUATE BRAKE SYSTEM TO SAFELY DECELERATE AND STOP TOWING VEHICLE AND DISABLED VEHICLE BEING TOWED.
- TOW DISABLED VEHICLE AT A REASONABLE SPEED TAKING INTO ACCOUNT ROAD CONDITIONS, ROAD GRADE, WEATHER, VISIBILITY AND STOPPING DISTANCE TO ASSURE SAFE OPERATION. POSTED SPEED LIMITS SHOULD BE OBSERVED AT ALL TIMES.
- MAKE SURE DISABLED VEHICLE'S:
 - FRONT AND REAR GUIDE WHEELS ARE RAISED AND LOCKED IN HIGHWAY POSITION.
 - VEHICLE STEERING WHEEL LOCK DISENGAGED.

FAILURE TO HEED THESE WARNINGS COULD RESULT IN SEVERE BODILY INJURY.



- TOWING EQUIPMENT (TOW TRUCK, TOW BARS, ETC.) MUST BE ATTACHED TO DISABLED VEHICLE'S FRAME. DO NOT MOUNT OR ATTACH TOWING EQUIPMENT TO DISABLED VEHICLE'S GUIDE WHEEL EQUIPMENT.
- TOWING EQUIPMENT (TOW TRUCK, TOW BARS, ETC.) MUST HAVE A RATED TOWING CAPACITY EQUAL TO OR GREATER THAN WEIGHT OF DISABLED VEHICLE BEING TOWED.
- OBSERVE AND FOLLOW ALL FEDERAL, STATE AND LOCAL DRIVING RULES AND REGULATIONS.
- STATE LAWS MAY REQUIRE TOWING VEHICLE AND DISABLED VEHICLE TO BE EQUIPPED WITH SPECIAL SAFETY EQUIPMENT (LIGHTS, ETC.).

FAILURE TO HEED THESE PRECAUTIONS COULD RESULT IN BODILY INJURY AND/OR PROPERTY DAMAGE.

2.15 Towing Disabled Vehicle On Road

1. See your vehicle's operators manual for towing information.
2. The towing vehicle must have an adequate brake system to safely decelerate and stop the towing vehicle and the disabled vehicle being towed.
3. Make sure that the disabled vehicle's:
 - a. Front and rear guide wheels are raised and locked in the highway position.
 - b. Vehicle steering wheel lock is disengaged on the steering column.
4. Make sure the towing vehicle is in good working condition (tires, brakes, lights, etc.) and that current maintenance has been performed on the vehicle.
5. The towing equipment (tow truck, tow bars, etc.) on the towing vehicle must have a rating equal to or greater than the weight of the disabled vehicle being towed.
6. The towing equipment (tow truck, tow bars, etc.) must be mounted or attached to the disabled vehicle's frame. Do not mount or attach the towing equipment to the disabled vehicle's guide wheel equipment.
7. Observe and follow all federal, state and local driving rules, regulations and laws.
8. State laws may require the towing vehicle and disabled vehicle being towed to be equipped with special safety equipment (lights, etc.).
9. Tow the disabled vehicle on the road at a reasonable speed taking into account road conditions, road grade, weather, visibility and stopping distance to assure safe operation. Always observe posted speed limits.

**SECTION 3 - ADJUSTMENTS
TABLE OF CONTENTS**

3.1 Guide Wheel Equipment Alignment Procedure 3 - 3

3.1.1 Vehicle Check 3 - 3

3.1.2 Placing Vehicle On Track 3 - 4

3.1.3 Guide Wheel Track Gauge 3 - 5

3.1.4 Front Guide Wheel Load On Track 3 - 5

3.1.5 String Lining Set-Up 3 - 7

3.1.6 Guide Wheel Alignment 3 - 8

3.1.6.1 Checking Guide Wheel Side to Side Alignment 3 - 8

3.1.6.2 Adjusting Guide Wheel Side to Side Alignment 3 - 8

3.1.6.3 Checking Guide Wheel Tracking 3 - 10

3.1.6.4 Adjusting Guide Wheel Tracking 3 - 10

3.1.7 Vehicle Track Test 3 - 12

3.2 Adjustments 3 - 14

3.2.1 Vehicle Front Tire Clearance - Rail Position 3 - 14

3.2.2 Brake Shoe Clearance 3 - 16

3.2.2.1 Checking Brake Shoe Clearance 3 - 16

3.2.2.2 Adjusting Brake Shoe Clearance 3 - 16

3.2.3 Rail Sweep Clearance 3 - 18

3.2.3.1 Checking Rail Sweep Clearance 3 - 18

3.2.3.2 Adjusting Rail Sweep Clearance 3 - 18

3.1 Guide Wheel Equipment Alignment Procedure



■ **ENGINE MUST BE RUNNING TO OPERATE MECHANICAL PTO HYDRAULIC PUMP TO RAISE / LOWER THE GUIDE WHEELS. BEFORE PERFORMING ANY ADJUSTMENTS TO GUIDE WHEEL EQUIPMENT OR VEHICLE, ALWAYS PLACE AUTOMATIC TRANSMISSION IN "PARK" OR MANUAL TRANSMISSION IN "NEUTRAL". APPLY THE PARKING BRAKE. FAILURE TO COMPLY COULD RESULT IN SEVERE BODILY INJURY.**

The Guide Wheel Alignment Procedure must be completed when the guide wheel equipment is applied to the vehicle, or when any of the misalignment indicators occur. See Operation - Misalignment Indicators.

See The Operator's Service and Parts Manual provided with the rear guide wheel unit for the proper alignment procedure for the rear guide wheel unit.

3.1.1 Vehicle Check

1. The vehicle must be at curb weight with permanent attachments: spare tire, tool box less tools, utility box, crane, aerial lift boom, etc. and without: passengers, baggage, load, etc.
2. Weigh the entire vehicle and record this weight. Weigh both the front and rear axles of the vehicle separately and record these weights. These weights will be used when calculating the guide wheel load.
3. The weight of the vehicle should not exceed the GVWR (Gross Vehicle Weight Rating) and the weight on the front and rear axles should not exceed their respective GAWR (Gross Axle Weight Rating).
4. Permanent attachments to the vehicle such as a tool box, utility box, crane, aerial lift boom, etc. which could cause uneven loading on the guide wheels should be compensated for, by adjusting the vehicle suspension by adding leaf springs, coil springs, torsion bars, etc.
5. Tires must be inflated to the tire manufacturer's recommended maximum pressure printed on the sidewalls of the tires or wheel manufacturer's recommended maximum pressure, stamped on the wheel, whichever is lower.
6. Visually inspect the entire vehicle, especially the guide wheel equipment, for loose or missing bolts, and bent or damaged components. Tighten, repair, or replace as necessary.
7. Verify that the vehicle the guide wheel equipment is to be mounted to is equipped correctly (springs, tires, wheels, etc.). See the Harsco Track Technologies HY-RAIL® Vehicle Specifications Manual.

3.1 Guide Wheel Equipment Alignment Procedure

3.1.1 Vehicle Check

8. Check the following measurements on the vehicle that the guide wheel equipment is to be mounted on before applying the guide wheel equipment to the vehicle.
 - a. Frame must be square. Diagonal measurements of the frame should be equal within 1/8 inch (3.2 mm).
 - b. Wheelbase (as measured on each side) must be equal within 1/16 inch (1.8 mm).
 - c. Vehicle axles must be square with the frame within 1/64 inch per foot (.4 mm per 304 mm). Harsco Track Technologies, Harsco Corporation recommends that this be checked by a reputable alignment shop.
9. Follow the mounting instructions on the application drawings which are supplied with each Guide Wheel Equipment Group.

Note: The applicator of the guide wheel equipment must make sure the application drawings remain with the vehicle for further reference. If the application drawings are not with the vehicle, contact Harsco Track Technologies, Fairmont Minnesota Facility to obtain these drawings.

10. After mounting the guide wheel equipment to the vehicle, have the caster, camber, and toe-in checked on the vehicle front wheels. If necessary, adjust to vehicle manufacturer's recommendations.
11. Have the headlight aim checked and adjusted, if necessary.

3.1.2 Placing Vehicle On Track

1. Place the vehicle on straight, level, tangent track or an alignment rack constructed for guide wheel equipment alignment. If track or an alignment rack is not available, use 4 x 4 inch lumber on a level floor to simulate track. Space the lumber so it measures 56-1/2 inches (1.435 m) between the inside edges.
2. Place the vehicle automatic transmission in "Park" or manual transmission in "Neutral". Apply the parking brake. Lower and lock the guide wheels in the rail position. See Operation - Placing Vehicle On Track.
3. Set the vehicle front wheels straight ahead. Secure the steering wheel using the steering lock. Stop the engine.

3.1 Guide Wheel Equipment Alignment Procedure

3.1.3 Guide Wheel Track Gauge - See Figure 3-1

1. Measure the track gauge of the front guide wheel unit. Measure from the back of the left wheel flange, directly below the center line of the wheel spindle, to the same point on the right wheel flange. This dimension must be 53-1/4 to 53-3/8 inches (1353 mm to 1356 mm). The track gauge is preset at the factory and is non-adjustable.

FIGURE 3-1
GUIDE WHEEL TRACK GAUGE

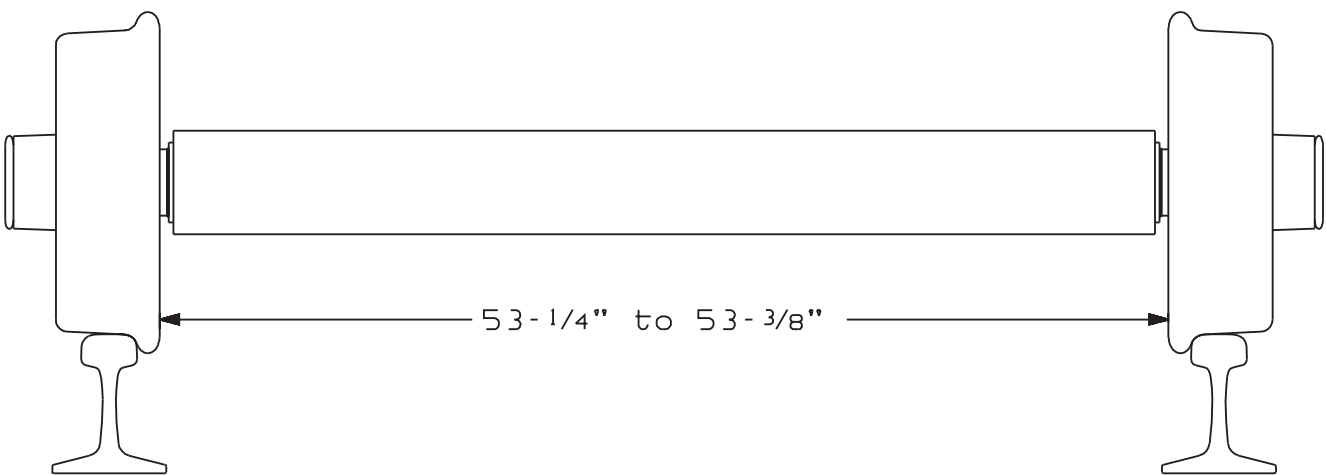

3.1.4 Front Guide Wheel Load On Track

1. The front guide wheel unit load capacity on track is non-adjustable. Whenever the vehicle is loaded or additional load is added to the existing vehicle load on track, check the load on the front guide wheels using the 159510 Wheel Load jack. See the Operation Section - Guide Wheel Load On Track.

3.1 Guide Wheel Equipment Alignment Procedure

FIGURE 3-2
GUIDE WHEEL EQUIPMENT ALIGNMENT

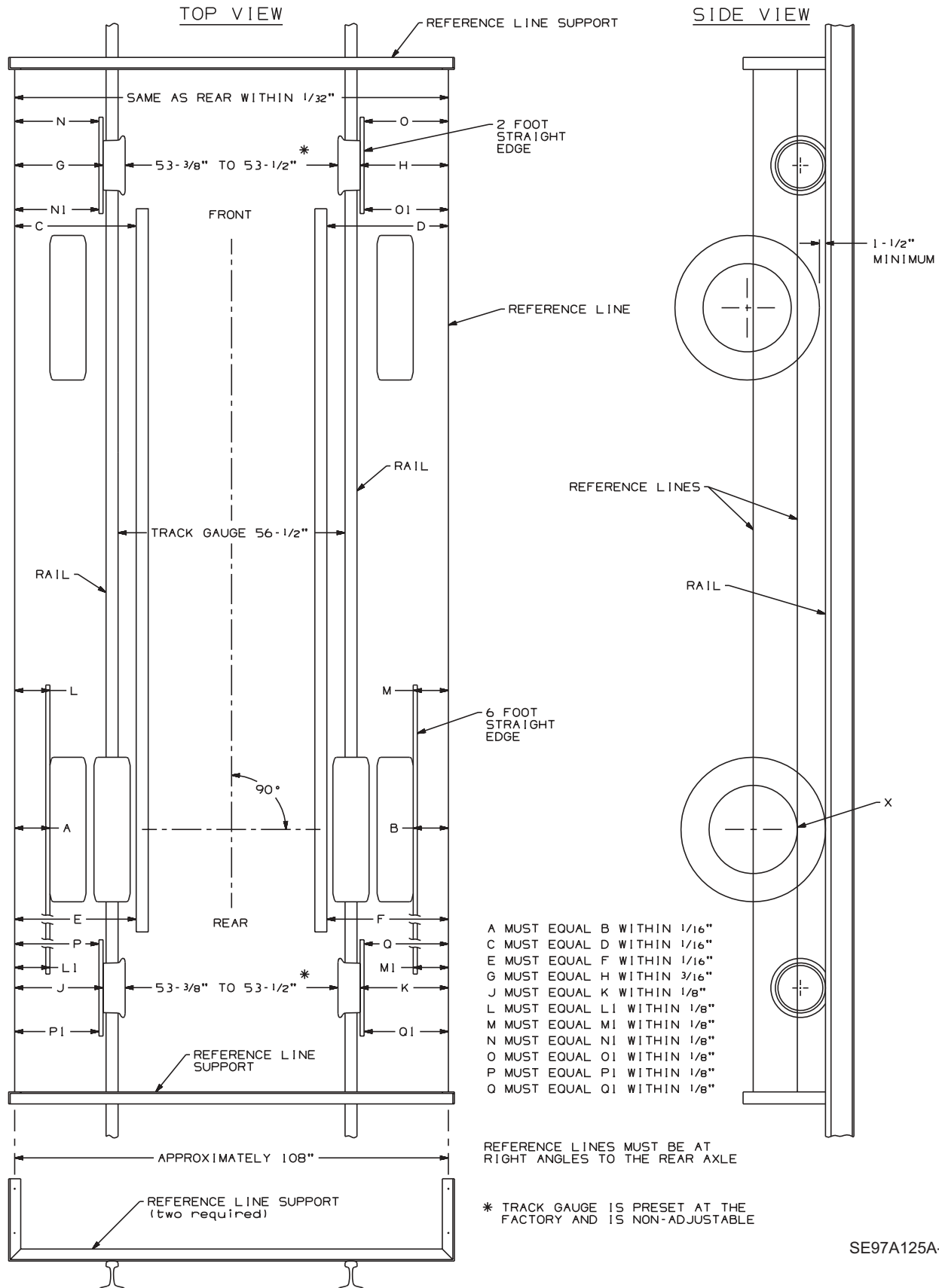

3

3.1 Guide Wheel Equipment Alignment Procedure

3.1.5 String Lining Set-Up - See Figure 3-2

1. The string lining procedure is only a guide to check and make alignment adjustments to the guide wheel equipment. String lining the vehicle and guide wheel equipment will not guarantee that the guide wheel equipped vehicle will track properly. Harsco Track Technologies recommends that all HY-RAIL® equipped vehicles be track tested. The vehicle should be at its normal operating load for track testing. The vehicle should be track tested when:
 - a. The guide wheel equipment is installed on the vehicle.
 - b. Any adjustments are made to the guide wheel equipment.
 - c. The load on the vehicle is changed.
 - d. Periodically to ensure that the vehicle is tracking properly.
2. Lower and lock both the front and rear guide wheel units in the "rail" position. See Operation Section - Placing Vehicle On Track. Set the vehicle wheels straight ahead. Secure the vehicle steering wheel using the steering lock.
3. Establish parallel reference lines on each side of the vehicle as shown in Figure 3-2. Parallel reference lines can be established by building two supports or brackets. These can be built out of scrap angle iron or other material. The supports must be high enough so the top reference line is through the center of the rear axle. The supports need to be a few inches longer than the width of the vehicle. Wires or cords stretched between the front and rear supports will be the reference lines. The wires or cords should be spaced approximately 108 inches (2743 mm) apart. The distance between the wires or cords must be equal or within 1/32 inch (.8 mm) at each support.
4. Clamp the supports to the rail in front of and behind the vehicle. The supports should be at right angles to the rail. Stretch the wires or cords between the supports, so the lower reference line is level with the bottom edge of the rear vehicle wheel rim(s) (point X) and the upper reference line is through the center of the rear axle(s). The reference lines must be level.
5. Shift the supports on the rail until dimension A equals (=) B and dimension C equals (=) D or within 1/16 inch (1.6 mm). Measurements A and B should be taken from the edge of the rear vehicle rim(s) directly below the axle (point X) to the reference lines. Measurements C and D are taken from the front of the vehicle frame. When shifting the supports, keep them at right angles to the rail so the reference lines stay level and parallel to each other.
6. Hold a six (6) foot straight edge against the outer edge of the rear, outside tires with the straight edge centered on the tires. Record dimensions L, L1, M and M1 to the reference line. Rotate the rear tires 180 degrees and record a second set of dimensions at L, L1, M and M1. Average the two dimensions taken at L, L1, M and M1.

Example: $[L \text{ (first dimension)} + L \text{ (second dimension)}] \div 2 = L \text{ (average dimension)}$

3.1 Guide Wheel Equipment Alignment Procedure

3.1.5 String Lining Set-Up - See Figure 3-2

7. Shift the supports on the rail until dimension L (average) equals (=) M (average) and dimension L1 (average) equals (=) M1 (average) or within 1/8 inch (3.2 mm). When shifting the supports, keep them at right angles to the rail so the reference lines stay level and parallel to each other. The reference lines will be parallel only when the rear axle is straight.
8. After the reference lines have been established, measurements can be taken from these lines to the guide wheels to help ensure correct alignment.

3

3.1.6 Guide Wheel Alignment

3.1.6.1 Checking Guide Wheel Side to Side Alignment - See Figure 3-2

1. Take measurements G and H. Measure from the outer edge of the guide wheel, directly below the center line of the wheel spindle, to the reference lines. Check that dimension G equals (=) H or is within 3/16 inch (4.8 mm). If not, determine the amount of side to side adjustment that will be required. Adjustment is accomplished by moving 1/16" and / or 1/18" shims between the mounting block (1) and the guide wheel unit upper structure (2).

3.1.6.2 Adjusting Guide Wheel Side to Side Alignment - See Figures 3-2, 3-3

1. Move the control valve handle to raise the guide wheels until all weight of the vehicle is removed from the guide wheel unit. Let the guide wheels rest on the rails.
2. Make sure the parking brakes are applied. Stop the vehicle engine.
3. To adjust the side to side alignment of the front guide wheel unit (dimensions G and H are equal or within 3/16 inch), remove the four 1/4 inch cap screws and nuts (3) that secure the 1/16" and 1/8" shims (4 & 5) in place.
 - a. If dimension G is greater than dimension H, remove an equal number of shim(s) (4) from both sides of the guide wheel unit, between the mounting block and the guide wheel unit upper structure. Insert shim(s) (4) between the mounting block and the guide wheel unit upper structure with shims (5). This will move the guide wheel unit towards the left and shorten dimension G. The measured thickness of the shim(s) that are moved should be equal to one-half (1/2) of the measured difference between G and H.
 - b. If dimension H is greater than dimension G, remove an equal number of shim(s) (5) from both sides of the guide wheel unit, between the mounting block and the guide wheel unit upper structure. Insert shim(s) (5) between the mounting block and the guide wheel unit upper structure with shims (4). This will move the guide wheel unit towards the right and shorten dimension H. The measured thickness of the shim(s) that are moved should be equal to one-half (1/2) of the measured difference between G and H.

3.1 Guide Wheel Equipment Alignment Procedure

3.1.6 Guide Wheel Alignment

3.1.6.2 Adjusting Guide Wheel Side to Side Alignment

4. Install the four 1/4 inch cap screws and nuts (3) that secure the 1/16" and 1/8" Shims (2 & 3) in place. Tighten the hex nuts securely.
5. Start the vehicle engine. Lower the guide wheel unit to the rail position. As the guide wheel unit is lowering to the rail, observe the guide wheel unit to vehicle component (engine, radiator, steering linkage, etc.) clearance. Make sure the guide wheel unit does not contact vehicle components as it is lowered to the rail and when it is in the rail position.
6. Recheck measurements G and H. Check that dimension G equals (=) H or is within 3/16 inch (4.8 mm). If not, repeat Steps 2, 3, 4 and 5 until dimension G equals (=) H or is within 3/16 inch (4.8 mm).

3

FIGURE 3-3
GUIDE WHEEL ALIGNMENT

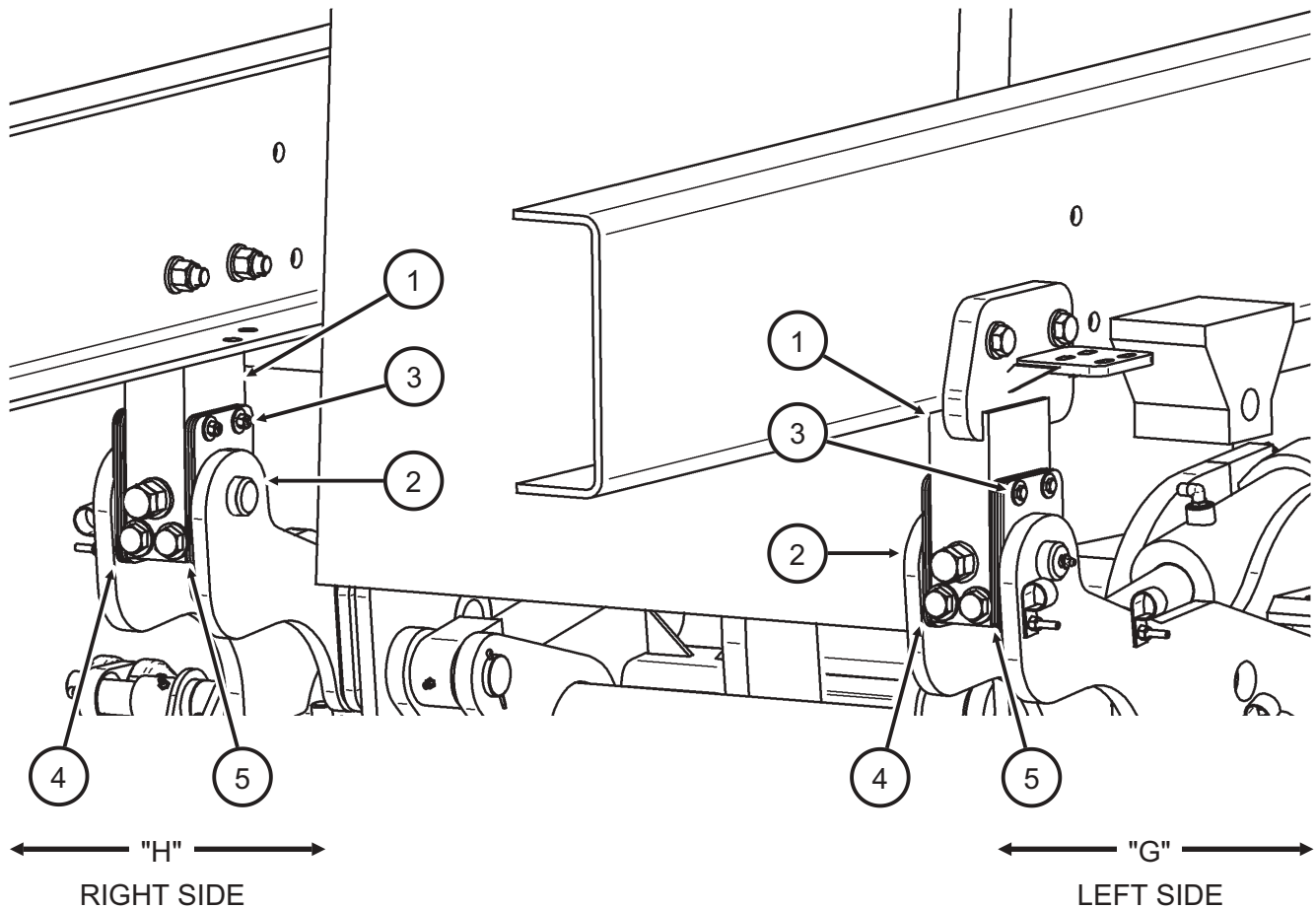

3.1 Guide Wheel Equipment Alignment Procedure

3.1.6 Guide Wheel Alignment

3.1.6.3 Checking Guide Wheel Tracking - See Figure 3-2

1. The front guide wheels must track straight. Hold a two foot long straight edge against the outer edge of the front guide wheel. Take measurements N and N1 and measurements O and O1. Check that dimension N equals (=) N1 and that dimension O equals (=) O1 or they are within 1/8 inch (3.2 mm). If not, adjustment is required. Adjustment is accomplished by moving 1/16" and / or 1/18" shims between the mounting block (1) and the guide wheel unit upper structure mounting pin (2).

3

3.1.6.4 Adjusting Guide Wheel Tracking - See Figures 3-2, 3-4

1. Move the control valve handle to raise the guide wheels until all weight of the vehicle is removed from the guide wheel unit. Let the guide wheels rest on the rails.
2. Make sure the parking brakes are applied. Stop the vehicle engine.
3. To adjust the guide wheel tracking, loosen and remove cap screws and hex nuts (3). Use caution, shims (4) may be loose and will fall out. Loosen the jam nut (5) on adjusting bolt (6). Turn adjusting bolt (6) counter-clockwise to remove the pressure of mounting pin (2) against shims (4). Again, use caution as shims (4) will fall out.
 - a. If dimension N is greater than N1 and dimension O is less than O1, rotate the left adjusting bolt (6) counter-clockwise to move the left side of the guide wheel unit rearward or rotate the right adjusting bolt (6) clockwise to move the right side of the guide wheel unit forward.
 - b. If dimension N is less than N1 and dimension O is greater than O1, rotate the left adjusting bolt (6) clockwise to move the left side of the guide wheel unit forward or rotate the right adjusting bolt (6) counter-clockwise to move the right side of the guide wheel unit rearward.
4. Insert an appropriate number of shims (4) to fill the space between the rear of mounting pin (2) and mounting block (1). Rotate adjusting bolt (6) counter-clockwise to snug mounting pin (2) against spacers (4). Tighten jam nut (3). Insert the extra shims (4) between the front of mounting pin (2) and mounting block (1). Insert cap screws and nuts (3) and tighten securely.
5. Start the vehicle engine. Lower the guide wheel unit to the rail position. As the guide wheel unit is lowering to the rail, observe the guide wheel unit to vehicle component (engine, radiator, steering linkage, etc.) clearance. Make sure the guide wheel unit does not contact vehicle components as it is lowered to the rail and when it is in the rail position.

3.1 Guide Wheel Equipment Alignment Procedure

3.1.6 Guide Wheel Alignment

3.1.6.4 Adjusting Guide Wheel Tracking

6. Recheck measurements N and N1 and measurements O and O1. Check that dimension N equals (=) N1 and that dimension O equals (=) O1 or they are within 1/8 inch (3.2 mm). If not, repeat Steps 2, 3, 4 and 5 until dimension N equals (=) N1 and dimension O equals (=) O1 or they are within 1/8 inch (3.2 mm)

FIGURE 3-4
GUIDE WHEEL ALIGNMENT

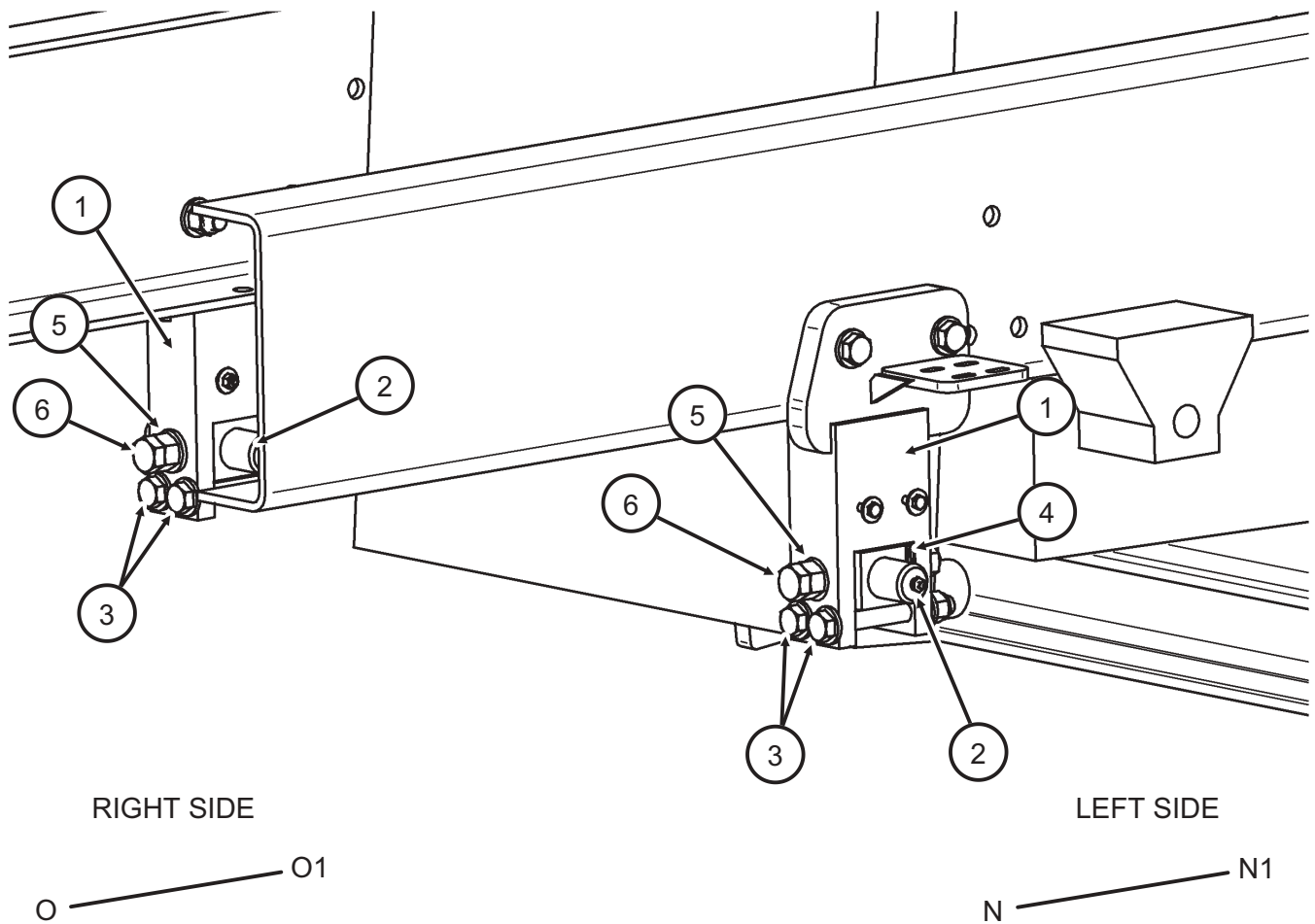

3.1 Guide Wheel Equipment Alignment Procedure

3.1.7 Vehicle Track Test



■ **CHECK AND CORRECT ALIGNMENT PROMPTLY IF MISALIGNMENT IS INDICATED. MISALIGNMENT OF GUIDE WHEEL EQUIPMENT COULD RESULT IN DERAILMENT OF THE VEHICLE AND SEVERE BODILY INJURY.**

3

1. Harsco Track Technologies recommends that all HY-RAIL® equipped vehicles be track tested. The vehicle should be at its normal operating load for track testing. The vehicle should be track tested when:
 - a. The guide wheel equipment is installed on the vehicle.
 - b. Any adjustments are made to the guide wheel equipment.
 - c. The load on the vehicle is changed.
 - d. Periodically to ensure that the vehicle is tracking properly.
2. The vehicle must be placed on straight, level, tangent track. See Operation Section - Placing Vehicle On Track.
3. Apply spray paint to the flanges and treads of all guide wheels.
4. Lower and lock both guide wheel units in the "rail" position.
5. Operate the vehicle for a short distance at a normal operating speed but not through switches and crossings.
6. The paint should wear evenly around the flanges and treads of all guide wheels. If the paint is worn evenly on all guide wheels, the vehicle and guide wheel equipment is properly aligned.
7. If the paint wore off the right front guide wheel flange and not off the left front guide wheel flange, the guide wheel unit is "flanging right".
 - a. Raise the guide wheel unit from the "rail" position. Let the guide wheels rest on the rail. See Adjusting Guide Wheel Tracking. Slightly move the right side of the guide wheel unit forward or the left side of the guide wheel unit rearward.
 - b. Repaint the flanges and treads on all guide wheels. Lower and lock the guide wheel unit in the "rail" Position. Operate the vehicle for a short distance at a normal operating speed. If the paint is worn evenly on all guide wheels, the vehicle and guide wheel equipment is properly aligned.
 - c. If the paint continues to wear off the right front guide wheel flange and not off the left front guide wheel flange, repeat Steps a. and b.

3.1 Guide Wheel Equipment Alignment Procedure

3.1.7 Vehicle Track Test

8. If the paint wore off the left front guide wheel flange and not off the right front guide wheel flange, the guide wheel unit is "flanging left".
 - a. Raise the guide wheel unit from the "rail" position. Let the guide wheels rest on the rail. See Adjusting Guide Wheel Tracking. Slightly move the left side of the guide wheel unit forward or the right side of the guide wheel unit rearward.
 - b. Repaint the flanges and treads on all guide wheels. Lower and lock the guide wheels in the "rail" Position. Operate the vehicle for a short distance at a normal operating speed. If the paint is worn evenly on all guide wheels, the vehicle and guide wheel equipment is properly aligned.
 - c. If the paint continues to wear off the left front guide wheel flange and not off the right front guide wheel flange, repeat Steps a. and b.
9. If the preceding procedure did not correct the tracking problem, note which guide wheels, flange and/or tread the paint is worn on.
 - a. Repaint the flanges and treads on all guide wheels.
 - b. Operate the vehicle in reverse for a short distance at a normal operating speed.
 - c. Note which guide wheels, flange and/or tread the paint is worn on.

If the paint wore off the right front flange when traveling forward and then off the left rear flange when traveling in reverse or off the left front flange when traveling forward and then off the right rear flange when traveling in reverse, the vehicle is probably not aligned properly. Have the frame checked for proper alignment. See Vehicle Check.
10. If the vehicle continues to track improperly, repeat the String Lining and Guide Wheel Alignment Procedure.

3.2 Adjustments

3.2.1 Vehicle Front Tire Clearance - Rail Position - See Figure 3-5

The vehicle's front tire clearance should be checked whenever the vehicle is placed on rail or whenever the load on the vehicle is changed significantly.

1. Place the vehicle on straight, level, tangent track. Place the vehicle automatic transmission in "Park" or manual transmission in "Neutral". Apply the parking brake. Lower and lock both guide wheel units in the "rail" position. See Operation Section - Placing Vehicle On Track.
2. When the front guide wheels are lowered and locked in the "rail" position, the guide wheel unit suspension linkage will raise the vehicle's front tires above the rails. This is necessary to ensure clearance when the vehicle passes through switches, turnouts, crossings, frogs, etc. As the vehicle is loaded, the front tire clearance will decrease. The front tires must always clear the top of the rails by a minimum of 1-1/2 inches (38 mm) whenever the vehicle is on track.
3. The vehicle front tire clearance is not adjustable. Vehicle front tire clearance is preset when the guide wheel unit is mounted to the vehicle.
4. When the guide wheel unit is mounted to the vehicle, the wheel arms are set to 15° - 20° over center. Stop blocks, one per each side of the guide wheel unit, are welded to the upper structure. These stop blocks not only prevent the wheel arms from traveling further rearward but are also the determining factor for vehicle front tire clearance.
5. When on rail, if the vehicle front tire clearance is less than 1-1/2 inch (38 mm) above the rail, some of the load must be removed from the vehicle until the minimum clearance of 1-1/2 inch (38 mm) is obtained. If the minimum clearance of 1-1/2 inch (38 mm) cannot be obtained, contact the HY-RAIL® Service Department at Harsco Track Technologies, Harsco Corporation, Fairmont, Minnesota.

3.2 Adjustments

3.2.1 Vehicle Front Tire Clearance - Rail Position

FIGURE 3-5
VEHICLE FRONT TIRE CLEARANCE

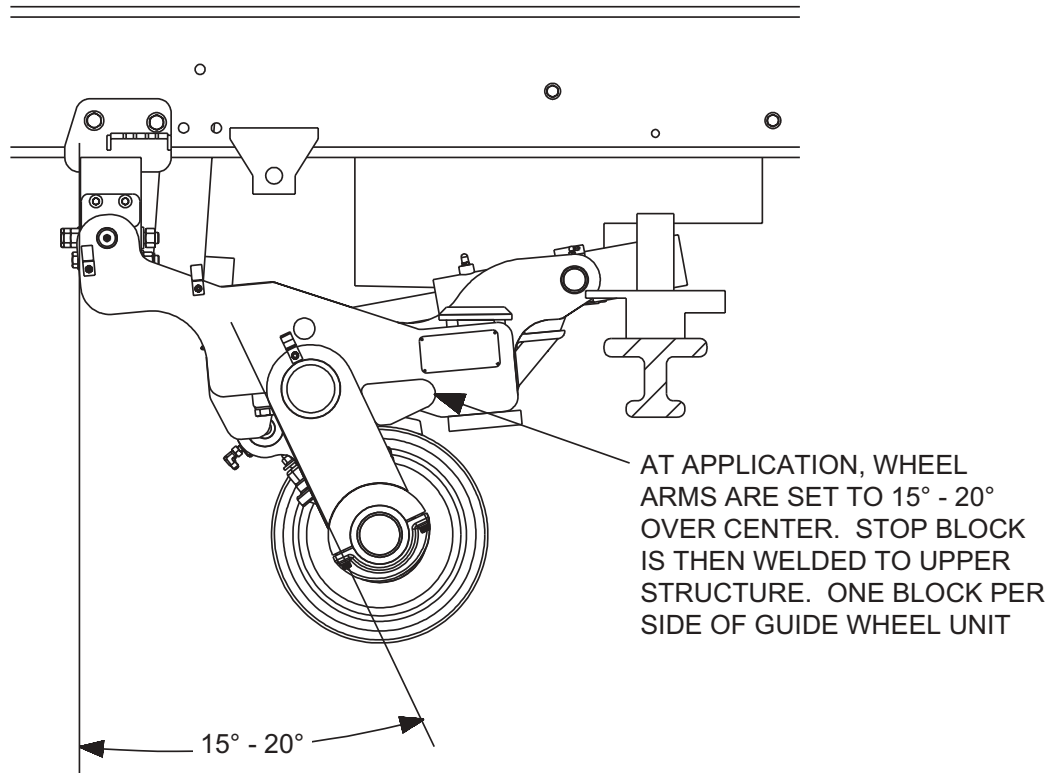

3.2 Adjustments

3.2.2 Brake Shoe Clearance

3.2.2.1 Checking Brake Shoe Clearance - See Figure 3-6

1. Apply the vehicle parking brakes. Be sure the vehicle air brake system is at operating pressure to fully release the guide wheel brakes. If so equipped, move the rail wheel brake control valve to the On position.
2. Measure the clearance between the brake shoe and the guide wheel tread. The clearance must not exceed 1/8 inch (3.2 mm), or adjustment is required.
3. Repeat Step 2 to check the brake shoe clearance on the other guide wheel brake.

3.2.2.2 Adjusting Checking Brake Shoe Clearance - See Figure 3-6

1. Remove the cotter pin from the pin (1). Remove the pin (1) from the yoke (2) on the brake actuator. Loosen jam nut (3) and turn yoke (2) counter-clockwise to adjust the brake shoe closer to the guide wheel tread or clockwise to adjust the brake shoe away from the guide wheel tread.
2. Adjust so the brake shoe is 1/32 - 1/16 inch (.8 - 1.6 mm) away from the guide wheel tread. Install the pin (1) through the yoke (2) and brake arm (4) and secure using the cotter pin. Tighten jam nut (3) securely. Recheck the brake shoe clearance.
3. Repeat this procedure to adjust the brake shoe clearance on the other guide wheel brake.

3.2 Adjustments

3.2.2 Brake Shoe Clearance

FIGURE 3-6
BRAKE SHOE CLEARANCE

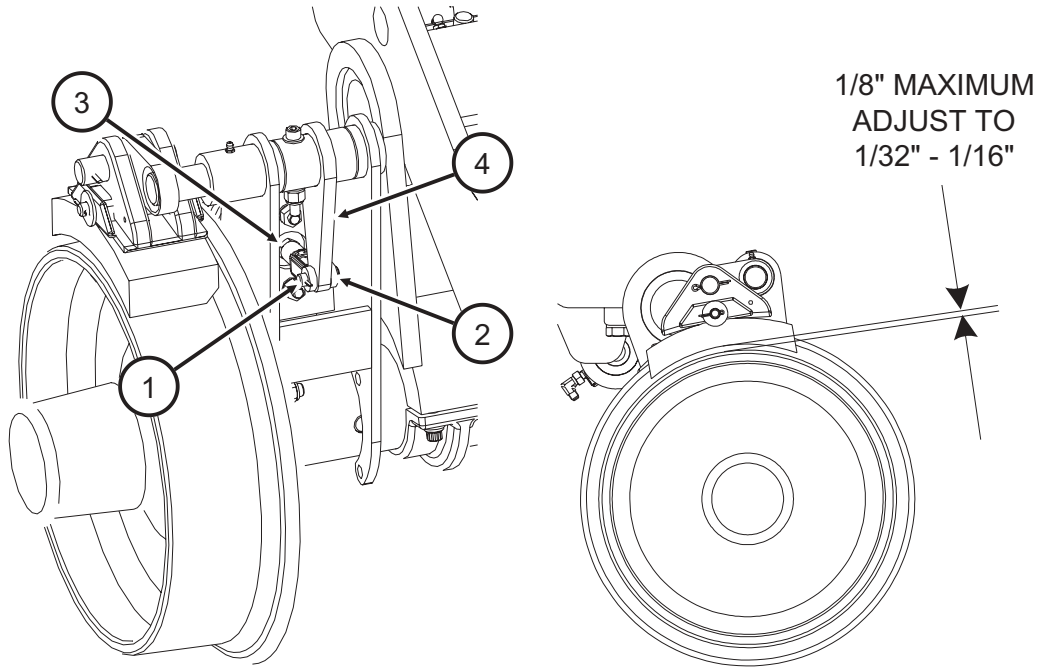

3.2 Adjustments

3.2.3 Rail Sweep Clearance

3.2.3.1 Checking Rail Sweep Clearance - See Figure 3-8

1. Place the vehicle on straight, level track. Place the vehicle automatic transmission in "Park" or manual transmission in "Neutral". Apply the vehicle parking / emergency brake. Lower and lock the front and rear guide wheels in the "rail" position.
2. The rubber rail sweeps should clear the top of the rail by $3/16$ inch (4.8 mm). If not, see Adjustment.

3.2.3.2 Adjusting Rail Sweep Clearance - See Figure 3-8

1. Loosen the two hex nuts (1) on cap screws (2). Slide the rubber sweep (3) down until it clears the top of the rail by $3/16$ inch (4.8 mm). Re-tighten the two hex nuts (1) and cap screws (2).
2. Repeat this procedure to adjust the rail sweep clearance on the other guide wheel.
3. When the rubber sweep is worn so it cannot be adjusted, replace the rubber sweep (3).

FIGURE 3-8
RAIL SWEEP CLEARANCE

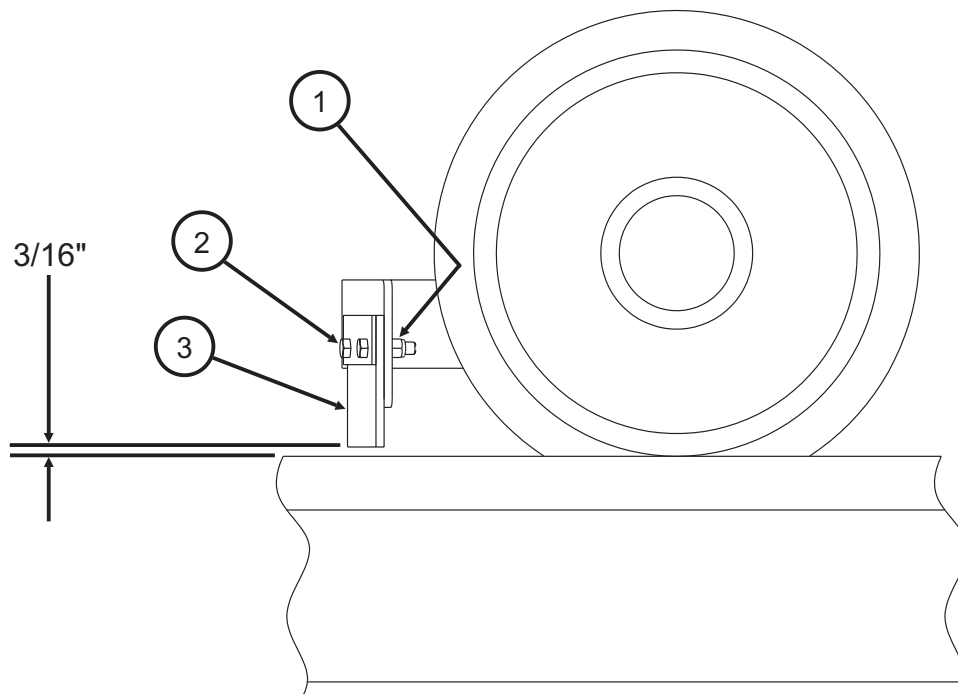

SE97A122A-1

**SECTION 4 - MAINTENANCE
TABLE OF CONTENTS**

4.1 Maintenance Schedule 4 - 2
4.1.1 Daily 4 - 2
4.1.2 Weekly 4 - 2
4.1.3 At 50 Vehicle Miles (80 Vehicle km) 4 - 3
4.1.4 At 2,000 Track Miles (3200 km) 4 - 3
4.1.5 At 10,000 Track Miles (16000 km) 4 - 3

4.2 Waste Disposal 4 - 3

4.3 Guide Wheel Equipment Lubrication 4 - 4
4.3.1 Guide Wheel Unit Lubrication 4 - 4
4.3.2 Re-Packing Guide Wheel Bearings. 4 - 5

4.4 Guide Wheels. 4 - 6
4.4.1 Allowable Wear. 4 - 6

4.5 Hoses And Fittings. 4 - 7
4.5.1 Inspection, Maintenance, Replacement And Installation. 4 - 7
4.5.2 Hose Band 4 - 7

4.6 Vehicle Wheels. 4 - 8
4.6.1 Wheel Replacement 4 - 8
4.6.2 Tire Replacement 4 - 8

4.7 Bolt Torque Requirements 4 - 8

4.1 Maintenance Schedule



■ **RE-TORQUE VEHICLE WHEEL LUG NUTS AND GUIDE WHEEL LUG NUTS AFTER THE FIRST 50 MILES OF OPERATION. THEREAFTER TORQUE WHEEL LUG NUTS ACCORDING TO VEHICLE MANUFACTURER'S WHEEL TORQUE SPECIFICATIONS. FAILURE TO COMPLY COULD RESULT IN SEVERE BODILY INJURY.**

4.1.1 Daily

1. Inspect the front and rear guide wheel units for damaged, worn or missing parts.
2. Check the mechanical and hydraulic locks and lock pins for ease of operation.
3. Check the hydraulic reservoir to ensure that the oil level is full. If low, fill to the proper level with the correct fluid.
4. When the vehicle is operated on the track, listen for unusual noises. Unusual noises may indicate incorrectly lowered guide wheels, damaged or missing parts, or insufficient lubrication. Pay attention to the quality of the ride. Check the guide wheel equipment alignment if the vehicle crowds one side of the track instead of floating from side to side. See Adjustments - Guide Wheel Equipment Alignment Procedure.

4

4.1.2 Weekly

1. Check the guide wheel equipment alignment. See Adjustment Section, Guide Wheel Equipment Alignment Procedure - Vehicle Track Test.
2. Inspect the guide wheel tread and flanges for wear or damage. See Maintenance - Guide Wheel Allowable Wear.
3. Spin each guide wheel by hand, checking for ease of rotation. If the guide wheel does not rotate easily, the guide wheel bearings may be lacking lubrication or may be damaged. Inspect, re-pack or replace the bearings if necessary.
4. Inspect the vehicle wheels, studs, lug nuts and tires for wear, damage, cuts etc.
5. Check the vehicle tires for correct inflation pressure. Operate at the tire manufacturer's recommended maximum pressure printed on the sidewalls of the tires, or the wheel manufacturer's recommended maximum pressure stamped on the wheel, whichever is lower.
6. Check all bolts for tightness. See Appendices - Appendix A, Bolt Torque Requirement Chart.

4.1 Maintenance Schedule

4.1.3 At 50 Vehicle Miles (80 Vehicle km)

Torque the vehicle wheel lug nuts and guide wheel lug nuts to the recommended specifications. Thereafter refer to the vehicle manufacturer's wheel torque specifications.

4.1.4 At 2,000 Track Miles (3200 km)

Lubricate the guide wheel unit locations provided with grease fittings. See Guide Wheel Equipment Lubrication.

4.1.5 At 10,000 Track Miles (16000 km)

Re-pack and adjust the guide wheel bearings. See Re-packing Guide Wheel Bearings.

4.2 Waste Disposal

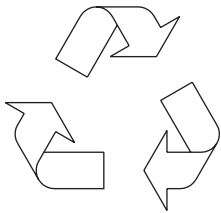

Dispose of waste properly. Improper disposal of waste can threaten the environment. The operation and maintenance of Harsco Track Technologies equipment may involve the use of such items as hydraulic oil, engine oil, fuel, coolant, brake fluid, filters, batteries, etc.

Use leak proof containers when draining fluids. Do not pour waste onto the ground, down a drain, or into any water source. Inquire on the proper way to recycle or dispose of waste according to applicable Federal, State and/or local regulations.

4.3 Guide Wheel Equipment Lubrication

Lubricate the guide wheel equipment every 2000 track miles (maximum) or each time the vehicle is serviced.

4.3.1 Guide Wheel Unit Lubrication - See Figure 4-1

1. Apply the vehicle parking brake. Stop the vehicle engine. Turn the vehicle's ignition switch off.
2. Lubricate grease fittings (A) using Mobil Special Moly, or equivalent.
3. Re-pack the guide wheel bearings (B) every 10,000 track miles (maximum) or at least once every two years (minimum), whichever occurs first. See Re-packing Guide Wheel Bearings.

FIGURE 4-1
GUIDE WHEEL UNIT LUBRICATION

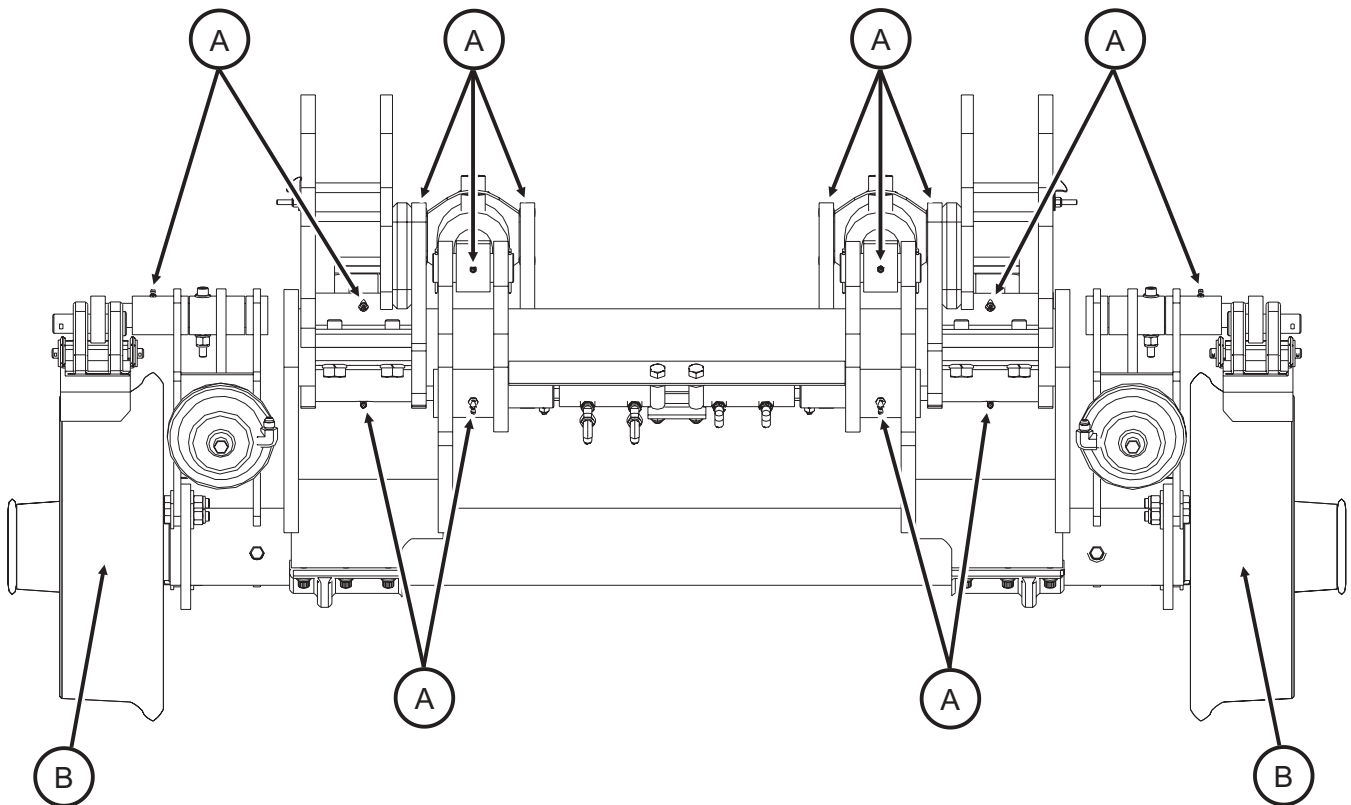

4.3 Guide Wheel Equipment Lubrication

4.3.2 Re-Packing Guide Wheel Bearings - See Figure 4-2

Re-pack the guide wheel bearings every 10,000 track miles (maximum) or at least once every two years (minimum), whichever occurs first.

1. Apply the parking brake. Raise and lock the front and rear guide wheel units in the "highway" position. Stop the vehicle engine. Shut off the vehicle ignition switch.
2. Remove the hub cap (1). Remove the 3/16 x 2-1/2 inch cotter pin (2), 1-1/2 inch castle nut (3) and spindle washer (4).
3. Pull the guide wheel (5) from the spindle (6). Remove the outer bearing cone (7) from the guide wheel (5). Remove the grease seal (11) and inner bearing cone (9) from the guide wheel (5).
4. Clean all components of old grease and dirt.
5. Inspect the spindle, bearing cones and cups (7 & 8, 9 & 10) for nicks, gouges and wear. If any of these are evident, replace the component.
6. Measure the guide wheel wear. See Maintenance - Guide Wheels, Allowable Wear.
7. Coat the spindle surface, grease seal surface, both bearing cup surfaces, pack both bearing cones and fill the guide wheel cavity 1/2 full (50 %) using Mobil HP grease, or equivalent.
8. Install the inner bearing cone (9) into the guide wheel (5). Install a new grease seal (11) into the wheel.
9. Slide the guide wheel (5) with the inner bearing (9) and grease seal (11) onto the spindle (6). Install the outer bearing cone (7), spindle washer (4) and 1-1/2 inch castle nut (3) onto the spindle (6).
10. Torque the castle nut (3) to approximately 20 ft lbs. Then loosen the castle nut. This is especially important if new bearing cups have been installed.
11. Torque the castle nut (3) to 7 ft lbs (zero clearance). Then back the castle nut off 1/2 to 1 flat of the nut (.001 - .010 inch clearance). Secure the castle nut using a new cotter pin (2).
12. Install the hub cap (1) onto the guide wheel.

FIGURE 4-2
RE-PACKING GUIDE WHEEL
BEARINGS

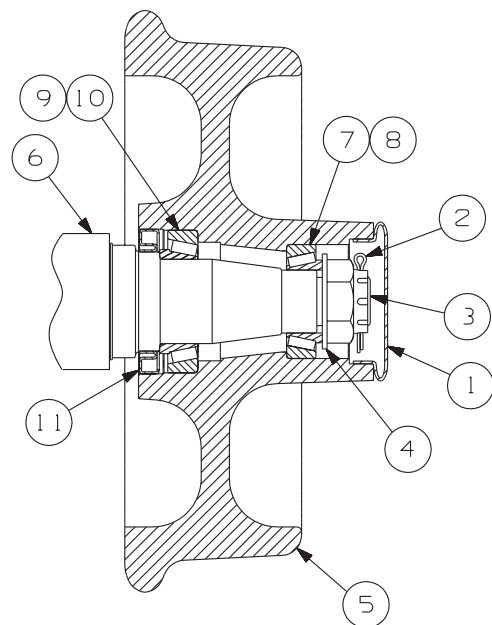

4.4 Guide Wheels

4.4.1 Allowable Wear - See Figure 4-3



■ **REPLACE ANY GUIDE WHEEL IMMEDIATELY WHICH SHOWS DAMAGE AND/OR HAS WORN MORE THAN THE ALLOWABLE LIMITS. FAILURE TO COMPLY COULD RESULT IN DERAILMENT OF THE VEHICLE, AND SEVERE BODILY INJURY.**

1. Tools needed: Harsco Track Technologies wheel caliper (M019889), or equivalent.
2. Measure the guide wheel flange at Position "A" with the wheel caliper. The minimum allowable flange dimension at Position "A" is 7/8 inch (22.2 mm).

If the guide wheel flange dimension is less than the allowable limit, replace the guide wheel immediately.

3. Measure the guide wheel tread at Position "B" with the wheel caliper. The minimum allowable tread dimension at Position "B" is 1/2 inch (12.7 mm).

If the guide wheel tread dimension is less than the allowable limit, replace the guide wheel immediately.

4. The entire guide wheel must not have any gouges or cracks. If any of these are evident, replace the guide wheel immediately.

FIGURE 4-3
ALLOWABLE GUIDE WHEEL WEAR

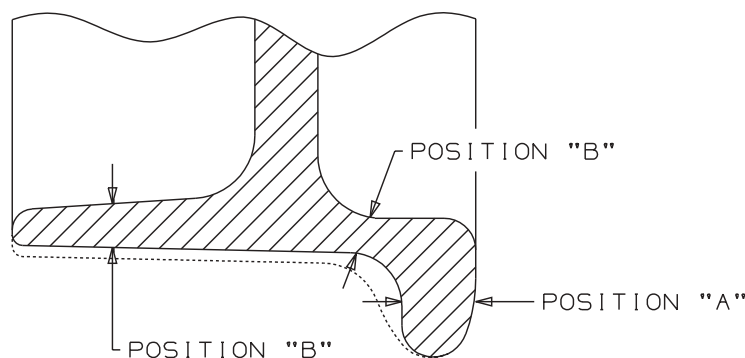

SE93A124A-1

4.5 Hoses and Fittings



■ ALL HOSES AND FITTINGS ON THIS EQUIPMENT MUST COMPLY WITH SAE STANDARD J1273 RECOMMENDED PRACTICE FOR SELECTION, INSTALLATION AND MAINTENANCE OF HOSE AND HOSE ASSEMBLIES. FAILURE TO COMPLY TO THIS STANDARD COULD RESULT IN SEVERE BODILY INJURY.

4.5.1 Inspection, Maintenance, Replacement And Installation

The inspection, maintenance, replacement and installation of hydraulic hose assemblies and fittings on this equipment must conform with SAE Standard J1273. See Appendices Section - Appendix B.

4.5.2 Hose Band - See Figure 4-4

All Harsco Track Technologies original and replacement hose assemblies manufactured for this equipment at the Harsco Track Technologies, Harsco Corporation Fairmont, Minnesota plant facility are supplied with a hose band displaying the date of manufacture and the Harsco Track Technologies part number. See Figure 4-4 for explanation of the hose band. The hose assembly illustrated in the example was manufactured in August 2004 and is Harsco Track Technologies part number 188662.

FIGURE 4-4
HOSE BAND

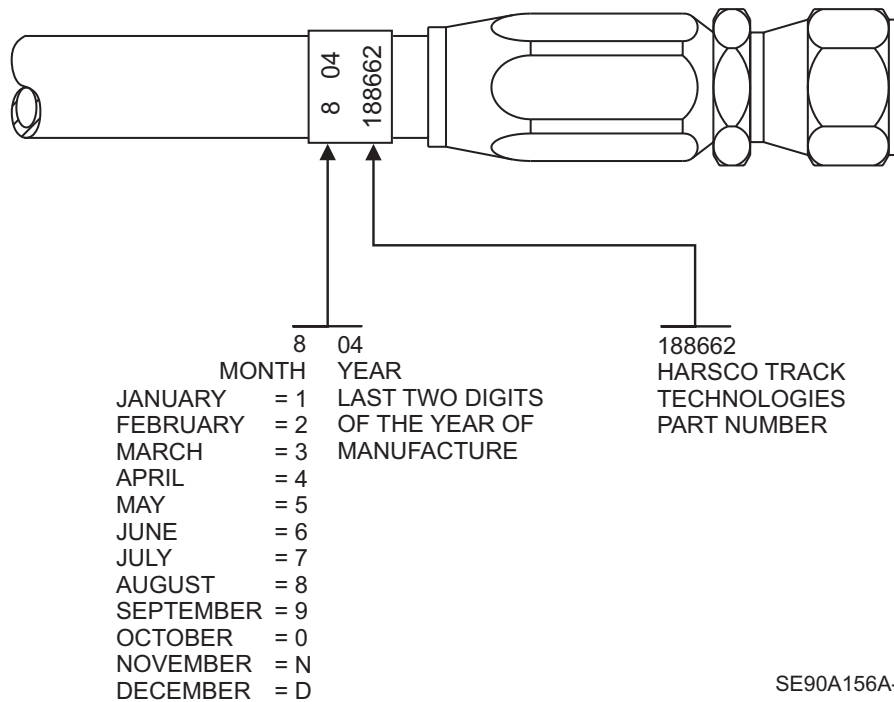

4.6 Vehicle Wheels

4.6.1 Wheel Replacement



- **USE REPLACEMENT WHEELS AS RECOMMENDED IN THE HARSCO TRACK TECHNOLOGIES HY-RAIL® VEHICLE SPECIFICATIONS MANUAL. FAILURE TO COMPLY COULD RESULT IN BODILY INJURY AND/OR PROPERTY DAMAGE.**

Use replacement wheel rim(s) as recommended in the Harsco Track Technologies HY-RAIL® Vehicle Specifications Manual to ensure correct vehicle wheel spacing and accurate guide wheel load. The wheels and tires should be static balanced or balanced after installation on the vehicle for best results. Torque vehicle wheel lug nuts to recommended specifications.

4.6.2 Tire Replacement

4



- **USE REPLACEMENT TIRES WITH THE SAME ROLLING RADIUS, TREAD WIDTH, PLY RATING, AND LOAD RATING AS RECOMMENDED IN THE HARSCO TRACK TECHNOLOGIES HY-RAIL® VEHICLE SPECIFICATIONS MANUAL. FAILURE TO COMPLY COULD RESULT IN BODILY INJURY AND/OR PROPERTY DAMAGE.**

Replacement tires must have the same rolling radius, tread width, ply rating, and load rating as recommended in the Harsco Track Technologies HY-RAIL® Vehicle Specifications Manual. Using tires of equal diameter will help keep the speedometer reading and the guide wheel load accurate. Tires must have a minimum 6-1/2 inches of tread width.

Inflate tires to the tire manufacturer's recommended maximum pressure printed on the sidewall of the tire or to the wheel manufacturer's recommended maximum pressure stamped on the wheel, whichever is lower. The wheels and tires should be static balanced or balanced after installation on the vehicle for best results. Torque vehicle wheel lug nuts to recommended specifications.

4.7 Bolt Torque Requirements



- **CHECK ALL BOLTS AND NUTS PERIODICALLY. KEEP BOLTS AND NUTS TIGHTENED TO THE TORQUE SPECIFIED IN APPENDICES SECTION - APPENDIX A. IF BOLT REPLACEMENT BECOMES NECESSARY, REPLACE WORN BOLT WITH EQUAL S.A.E. GRADE NUMBER BOLT. FAILURE TO COMPLY COULD RESULT IN BODILY INJURY, AND/OR PROPERTY DAMAGE.**

See Appendices Section - Appendix A, for bolt torque requirements table and grade identification markings used by manufacturers.

**SECTION 5 - TROUBLESHOOTING
TABLE OF CONTENTS**

5.1 Troubleshooting Guide Wheel Equipment 5 - 2

5.1 Troubleshooting Guide Wheel Equipment

PROBLEM	PROBABLE CAUSE	POSSIBLE REMEDY
Hydraulic pump not delivering oil.	<p>Mechanical PTO not engaged or control valve not shifted to direct oil flow to guide wheel equipment.</p> <p>Switch for auxiliary electric powered hydraulic pump in OFF position.</p> <p>Hydraulic reservoir oil level low.</p> <p>Oil restricted to pump intake.</p> <p>Components bent, broken, worn, etc.</p>	<p>Engage mechanical PTO. Shift control valve to direct oil flow to guide wheel equipment.</p> <p>Move switch to ON position.</p> <p>Fill reservoir to full level with recommended hydraulic oil.</p> <p>Check all strainers and filters for dirt and sludge. Clean and replace if necessary.</p> <p>Replace components.</p>
<p>5 Guide wheel unit does not lower or raise.</p>	<p>Lock pins engaged.</p> <p>Hydraulic pump not operating.</p> <p>Hydraulic reservoir oil level low.</p> <p>Components bent, broken, worn, etc.</p>	<p>Disengage lock pins. See Operation Section - Placing Vehicle On Track or Removing Vehicle From Track.</p> <p>Start hydraulic pump.</p> <p>Fill reservoir to full level with recommended hydraulic oil.</p> <p>Replace components.</p>
Guide wheel unit is difficult to lower or raise.	<p>Vehicle over-loaded.</p> <p>Components bent, broken, worn, etc.</p>	<p>Remove excess load from vehicle.</p> <p>Replace components.</p>
Lock will not engage when guide wheel unit is in "highway" position.	<p>Components bent, broken, worn, etc.</p>	<p>Replace components.</p>

5.1 Troubleshooting Guide Wheel Equipment

PROBLEM	PROBABLE CAUSE	POSSIBLE REMEDY
<p>Vehicle front tires clear rail less than 1-1/2" (38 mm) when vehicle is on track and loaded.</p>	<p>Vehicle overloaded.</p> <p>Guide wheel unit not applied properly.</p>	<p>Redistribute or remove some of the load.</p> <p>See application drawings supplied with guide wheel equipment group.</p>
<p>Vehicle derails.</p>	<p>Guide wheel units, vehicle rear axle, etc. not aligned with vehicle frame.</p>	<p>Check alignment. See Adjustment Section - Guide Wheel Equipment Alignment Procedure.</p>
<p>Vehicle pulls noticeably to the left or right when on track.</p>	<p>Vehicle loaded heavy on one side.</p> <p>Guide wheel units, vehicle rear axle, etc. not aligned with vehicle frame.</p> <p>Incorrect or worn vehicle rear tire.</p> <p>Vehicle rear tires under inflated.</p> <p>Guide wheel brake shoes dragging.</p>	<p>Move load to center of vehicle.</p> <p>Check alignment. See Adjustment Section - Guide Wheel Equipment Alignment Procedure.</p> <p>Check for correct rear tire. Replace if necessary. Replace worn rear tire.</p> <p>Check pressure. Inflate if low.</p> <p>Do not exceed tire manufacturer's recommended maximum pressure printed on the sidewalls, or wheel manufacturer's recommended maximum pressure stamped on the wheel, whichever is lower.</p> <p>Re-adjust brake shoes. See Adjustment Section - Brake Shoe Clearance.</p>

5.1 Troubleshooting Guide Wheel Equipment

PROBLEM	PROBABLE CAUSE	POSSIBLE REMEDY
<p>Vibration felt in the vehicle when traveling on track.</p>	<p>Guide wheel units mounting fasteners loose.</p> <p>Guide wheel bearings worn.</p> <p>Guide wheels worn.</p> <p>Vehicle rear rim bent.</p> <p>Vehicle rear tires out of balance.</p>	<p>Tighten all bolts to recommended torque.</p> <p>Replace bearings, wheel or axle.</p> <p>Check guide wheel wear. See Maintenance Section - Guide Wheels, Allowable Wear.</p> <p>Replace. See Parts Section - Vehicle Applications.</p> <p>Balance tires.</p>
<p>Vehicle load exceeds front Guide wheel unit maximum rated load.</p>	<p>Vehicle overloaded.</p>	<p>Redistribute or remove some of the load.</p>
<p>Vibration felt in the vehicle when traveling on highway.</p>	<p>Guide wheel units mounting fasteners loose.</p> <p>Guide wheel units not locked in "highway" position.</p> <p>Vehicle rim bent.</p> <p>Vehicle tires out of balance.</p>	<p>Tighten all bolts to recommended torque.</p> <p>STOP IMMEDIATELY. Make sure both guide wheel units are locked in "highway" position.</p> <p>Replace. See Parts Section - Vehicle Applications.</p> <p>Balance tires.</p>

5

**SECTION 6 - APPENDICES
TABLE OF CONTENTS**

6.1 Appendix A - Conversion Tables

BOLT TORQUE REQUIREMENTS - STANDARD TYPE FASTENERS..... 6 - 2
BOLT TORQUE REQUIREMENTS - SERRATED TYPE FLANGE FASTENERS 6 - 3
BOLT TORQUE REQUIREMENTS - METRIC TYPE FASTENERS..... 6 - 4
INCH TO MILLIMETERS 6 - 6
FEET TO METERS..... 6 - 6
POUNDS TO KILOGRAMS 6 - 7
POUNDS PER SQUARE INCH TO BAR 6 - 7
POUNDS PER SQUARE INCH TO KILOPASCALS..... 6 - 7
FAHRENHEIT TO CELSIUS (Centigrade) 6 - 8
MILES PER HOUR TO KILOMETERS PER HOUR 6 - 9
GALLONS TO LITERS 6 - 9

6.2 Appendix B - SAE J1273



SAE J1273 - DEC 2002
RECOMMENDED PRACTICES FOR HYDRAULIC HOSE ASSEMBLIES..... 6 - 11

6.1 Appendix A

FIGURE 6-1
STANDARD BOLT TORQUE REQUIREMENTS TABLE
STANDARD TYPE FASTENERS

The torque values listed below are for standard-type fasteners only. The torque values listed are based on wet and (lubricated) dry conditions. The torque values for 1/4 and 5/16 inch size fasteners are listed in lb-in and N-m torque equivalents. The torque values for all other size fasteners are listed lb-ft and N-m torque equivalents. Use lower grade torque values if bolt and nut have different SAE grades. Manufacturer's SAE grade markings may vary.

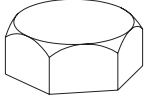
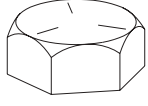
STANDARD MARKINGS AND TORQUE SPECIFICATIONS



SAE Grade	1 or 2				5				8			
Fastener Standard SAE Grade Markings												
Fastener Body Size Inch-Thread	Torque				Torque				Torque			
	Wet		Dry		Wet		Dry		Wet		Dry	
	lb-in	N-m	lb-in	N-m	lb-in	N-m	lb-in	N-m	lb-in	N-m	lb-in	N-m
1/4 - 20	49	5.5	65	7.3	75	8.5	100	11.3	107	12.0	142	16.0
1/4 - 28	56	6.5	74	8.3	86	9.7	114	12.8	122	13.8	162	18.3
5/16 - 18	103	11.6	137	15.5	157	17.7	208	23.5	220	24.8	293	33.1
5/16 - 24	113	12.7	150	16.9	173	19.5	230	25.9	244	27.5	325	36.7
Fastener Body Size Inch-Thread	Torque				Torque				Torque			
	Wet		Dry		Wet		Dry		Wet		Dry	
	lb-ft	N-m	lb-ft	N-m	lb-ft	N-m	lb-ft	N-m	lb-ft	N-m	lb-ft	N-m
3/8 - 16	15	20	20	27	23	31	31	42	32	43	43	58
3/8 - 24	17	23	23	31	26	35	35	47	37	50	49	66
7/16 - 14	24	32	32	43	37	50	49	66	52	70	69	93
7/16 - 20	27	36	36	49	42	57	56	76	58	78	77	104
1/2 - 13	39	53	52	70	57	77	76	103	80	108	106	144
1/2 - 20	41	55	55	74	64	87	85	115	90	122	120	163
9/16 - 12	53	72	71	96	82	111	109	148	115	156	153	207
9/16 - 18	59	80	78	106	91	123	121	164	129	175	172	233
5/8 - 11	73	99	97	131	113	155	150	203	160	217	213	289
5/8 - 18	83	112	110	149	128	173	170	230	180	244	239	324
3/4 - 10	129	175	172	233	200	271	266	361	282	382	375	508
3/4 - 16	144	195	192	260	223	302	297	403	315	427	419	568
7/8 - 9	124	168	165	224	323	438	430	583	454	615	604	819
7/8 - 14	138	187	184	249	355	481	472	640	501	679	666	903
1 - 8	188	255	250	339	483	655	642	870	681	923	906	1228
1 - 14	210	285	279	378	541	733	720	976	764	1036	1016	1377
1-1/8 - 7	266	361	354	480	596	808	793	1075	966	1310	1285	1742
1-1/8 - 12	297	403	395	535	668	906	888	1204	1083	1468	1440	1952
1-1/4 - 7	375	508	499	676	841	1140	1119	1517	1363	1848	1813	2458
1-1/4 - 12	415	563	552	748	930	1261	1237	1677	1509	2046	2007	2721
1-3/8 - 6	492	667	654	887	1102	1494	1466	1988	1787	2423	2377	3223
1-3/8 - 12	560	759	745	1010	1255	1701	1670	2264	2034	2758	2705	3667
1-1/2 - 6	653	885	868	1177	1463	1983	1946	2638	2371	3215	3153	4275
1-1/2 - 12	734	995	976	1323	1645	2230	2188	2966	2668	3617	3548	4810

6.1 Appendix A

FIGURE 6-2
STANDARD BOLT TORQUE REQUIREMENTS TABLE
SERRATED TYPE FLANGE FASTENERS

The torque values listed below are for serrated-type flange fasteners only. The torque values listed are based on wet (lubricated) and dry conditions. The torque values for all other size fasteners are listed in lb-ft and N-m torque equivalents. Use lower grade torque values if bolt and nut have different SAE grades. Manufacturer's SAE grade markings may vary.

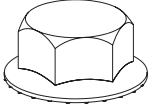
STANDARD MARKINGS AND TORQUE SPECIFICATIONS

SAE Grade	1 or 2				5			
Fastener Standard SAE Grade Markings								
Fastener Body Size Inch-Thread	Torque				Torque			
	Wet		Dry		Wet		Dry	
	lb-ft	N-m	lb-ft	N-m	lb-ft	N-m	lb-ft	N-m
1/4 - 20	8	10.8	11	14.9	11	14.9	15	20.3
1/4 - 28	9	12.2	12	16.3	12	16.3	16	21.7
5/16 - 18	13	17.6	17	23.0	20	27.1	27	36.6
5/16 - 24	13	17.6	17	23.0	32	43.3	43	58.3
3/8 - 16	23	31	31	42	40	54	53	72
3/8 - 24	25	34	33	45	43	58	57	77
7/16 - 14	38	51	51	69	55	74	73	99
7/16 - 20	40	54	53	72	60	81	80	108
1/2 - 13	60	81	80	108	95	129	127	172
1/2 - 20	65	88	87	118	100	135	133	180
9/16 - 12	78	106	104	141	140	190	187	253
9/16 - 18	85	115	113	153	150	203	200	271
5/8 - 11	125	169	167	226	190	258	253	343
5/8 - 18	135	183	180	244	220	298	293	397
3/4 - 10	225	305	300	407	350	474	467	633
3/4 - 16	250	339	333	451	400	542	533	723
7/8 - 9	350	474	467	633	550	746	733	994
7/8 - 14	375	508	500	678	600	813	800	1085
1 - 8	480	651	640	868	750	1017	1000	1356
1 - 14	500	678	666	903	800	1085	1066	1445

6.1 Appendix A

FIGURE 6-3
BOLT TORQUE REQUIREMENTS TABLE
METRIC TYPE FASTENERS

Do not use these values if a different torque value or tightening procedure is given for a specific application. Torque values listed are for general use only. Check tightness of fasteners periodically. Fasteners should be replaced with the same or higher property class. If higher property class fasteners are used, these should only be tightened to the strength of the original. Make sure fastener's threads are clean and that thread engagement is properly started. This will help prevent them from failing when tightening.

*Lubricated means coated with a lubricant such as engine oil, or fasteners with phosphate and oil coatings. Dry means plain or zinc plated without any lubrication.

Property Class and Head Markings	4.8				8.8				9.8							
Property Class and Head Markings	5				10											
Size	Class 4.8								Class 8.8 or 9.8							
	* Lubricated				* Dry				* Lubricated				* Dry			
	N - m		lb - ft		N - m		lb - ft		N - m		lb - ft		N - m		lb - ft	
M 6	4.8		3.5		6		4.5		9		6.5		11		8.5	
M 8	12		8.5		15		11		22		16		28		20	
M10	23		17		29		21		43		32		55		40	
M12	40		29		50		37		75		55		95		70	
M14	63		47		80		60		120		88		150		110	
M16	100		73		125		92		190		140		240		175	
M18	135		100		175		125		260		195		330		250	
M20	190		140		240		180		375		275		475		350	
M22	260		190		330		250		510		375		650		475	
M24	330		250		425		310		650		475		825		600	
M27	490		360		625		450		950		700		1200		875	
M30	675		490		850		625		1300		950		1650		1200	
M33	900		675		1150		850		1750		1300		2200		1650	
M36	1150		850		1450		1075		2250		1650		2850		2100	

6

6.1 Appendix A

FIGURE 6-4
BOLT TORQUE REQUIREMENTS TABLE
METRIC TYPE FASTENERS

Do not use these values if a different torque value or tightening procedure is given for a specific application. Torque values listed are for general use only. Check tightness of fasteners periodically. Fasteners should be replaced with the same or higher property class. If higher property class fasteners are used, these should only be tightened to the strength of the original. Make sure fastener's threads are clean and that thread engagement is properly started. This will help prevent them from failing when tightening.

* Lubricated means coated with a lubricant such as engine oil, or fasteners with phosphate and oil coatings.
Dry means plain or zinc plated without any lubrication.

Property Class and Head Markings								
Size	Class 10.9				Class 12.9			
	* Lubricated		* Dry		* Lubricated		* Dry	
	N - m	lb - ft	N - m	lb - ft	N - m	lb - ft	N - m	lb - ft
M 6	13	9.5	17	12	15	11.5	19	14.5
M 8	32	24	40	30	37	28	47	35
M10	63	47	80	60	75	55	95	70
M12	110	80	140	105	130	95	165	120
M14	175	130	225	165	205	150	260	190
M16	275	200	350	255	320	240	400	300
M18	375	275	475	350	440	325	560	410
M20	530	400	675	500	625	460	800	580
M22	725	540	925	675	850	625	1075	800
M24	925	675	1150	850	1075	800	1350	1000
M27	1350	1000	1700	1250	1600	1150	2000	1500
M30	1850	1350	2300	1700	2150	1600	2700	2000
M33	2500	1850	3150	2350	2900	2150	3700	2750
M36	3200	2350	4050	3000	3750	2750	4750	3500

6.1 Appendix A

FIGURE 6-5
INCH TO MILLIMETER CONVERSION TABLE
1 INCH = 25.4 MILLIMETERS

FRACTIONS	DECIMALS	MILLIMETERS	FRACTIONS	DECIMALS	MILLIMETERS
1/64	.016	0.397	33/64	.516	13.097
1/32	.031	0.794	17/32	.531	13.494
3/64	.047	1.191	35/64	.547	13.891
1/16	.063	1.588	9/16	.563	14.288
5/64	.078	1.984	37/64	.578	14.684
3/32	.094	2.381	19/32	.594	15.081
7/64	.109	2.778	39/64	.609	15.478
1/8	.125	3.175	5/8	.625	15.875
9/64	.141	3.572	41/64	.641	16.272
5/32	.156	3.969	21/32	.656	16.669
11/64	.172	4.366	43/64	.672	17.066
3/16	.188	4.763	11/16	.688	17.463
13/64	.203	5.159	45/64	.703	17.859
7/32	.219	5.556	23/32	.719	18.256
15/64	.234	5.953	47/64	.734	18.653
1/4	.250	6.350	3/4	.750	19.050
17/64	.266	6.747	49/64	.766	19.447
9/32	.281	7.144	25/32	.781	19.844
19/64	.297	7.541	51/64	.797	20.241
5/16	.313	7.938	13/16	.813	20.638
21/64	.328	8.334	53/64	.828	21.034
11/32	.344	8.731	27/32	.844	21.431
23/64	.359	9.128	55/64	.859	21.828
3/8	.375	9.525	7/8	.875	22.225
25/64	.391	9.922	57/64	.891	22.622
13/32	.406	10.319	29/32	.906	23.019
27/64	.422	10.716	59/64	.922	23.416
7/16	.438	11.113	15/16	.938	23.813
29/64	.453	11.509	61/64	.953	24.209
15/32	.469	11.906	31/32	.969	24.606
31/64	.484	12.303	63/64	.984	25.003
1/2	.500	12.700	1	1.000	25.400

FIGURE 6-6
FEET TO METERS CONVERSION TABLE
1 FOOT = 0.3048 METER

FEET	METERS	FEET	METERS	FEET	METERS	FEET	METERS	FEET	METERS
100	30.480	10	3.048	1	0.305	0.1	0.030	0.01	0.003
200	60.960	20	6.096	2	0.610	0.2	0.061	0.02	0.006
300	91.440	30	9.144	3	0.914	0.3	0.091	0.03	0.009
400	121.920	40	12.192	4	1.219	0.4	0.122	0.04	0.012
500	152.400	50	15.240	5	1.524	0.5	0.152	0.05	0.015
600	182.880	60	18.288	6	1.829	0.6	0.183	0.06	0.018
700	213.360	70	21.336	7	2.134	0.7	0.213	0.07	0.021
800	243.840	80	24.384	8	2.438	0.8	0.244	0.08	0.024
900	274.320	90	27.432	9	2.743	0.9	0.274	0.09	0.027
1,000	304.800	100	30.480	10	3.048	1.0	0.305	0.10	0.030

6

6.1 Appendix A

FIGURE 6-7
POUNDS TO KILOGRAMS CONVERSION TABLE
1 POUND = 0.4536 KILOGRAM

LB	KG	LB	KG	LB	KG	LB	KG	LB	KG
1,000	453.59	100	45.36	10	4.54	1	0.45	0.1	0.05
2,000	907.18	200	90.72	20	9.07	2	0.91	0.2	0.09
3,000	1,360.78	300	136.08	30	13.61	3	1.36	0.3	0.14
4,000	1,814.37	400	181.44	40	18.14	4	1.81	0.4	0.18
5,000	2,267.96	500	226.80	50	22.68	5	2.27	0.5	0.23
6,000	2,721.55	600	272.16	60	27.22	6	2.72	0.6	0.27
7,000	3,175.15	700	317.51	70	31.75	7	3.18	0.7	0.32
8,000	3,628.74	800	362.87	80	36.29	8	3.63	0.8	0.36
9,000	4,082.33	900	408.23	90	40.82	9	4.08	0.9	0.41
10,000	4,535.92	1,000	453.59	100	45.36	10	4.54	1.0	0.45

FIGURE 6-8
POUNDS PER SQUARE INCH TO BAR CONVERSION TABLE
1 PSI = 0.06895 BAR

PSI	BAR	PSI	BAR	PSI	BAR	PSI	BAR
1,000	68.95	100	6.90	10	0.69	1	0.07
2,000	137.90	200	13.79	20	1.38	2	0.14
3,000	206.84	300	20.68	30	2.07	3	0.21
4,000	275.80	400	27.58	40	2.76	4	0.28
5,000	344.70	500	34.47	50	3.45	5	0.35
6,000	413.64	600	41.36	60	4.14	6	0.41
7,000	482.58	700	48.26	70	4.83	7	0.48
8,000	551.52	800	55.15	80	5.52	8	0.55
9,000	620.46	900	62.05	90	6.21	9	0.62
10,000	689.48	1,000	68.95	100	6.90	10	0.69

6

FIGURE 6-9
POUNDS PER SQUARE INCH TO KILOPASCALS CONVERSION TABLE
1 PSI = 6.895 kPa

PSI	kPa	PSI	kPa
10	68.95	1	6.90
20	137.90	2	13.79
30	206.84	3	20.68
40	275.80	4	27.58
50	344.70	5	34.47
60	413.64	6	41.36
70	482.58	7	48.26
80	551.52	8	55.15
90	620.46	9	62.05
100	689.48	10	68.95

6.1 Appendix A

FIGURE 6-10
FAHRENHEIT TO CELSIUS (Centigrade) CONVERSION TABLE
(DEGREES F - 32°) ÷ 1.8 = DEGREES C

deg F	deg C	deg F	deg C	deg F	deg C	deg F	deg C
1	-17.2	51	10.6	101	38.3	151	66.1
2	-16.7	52	11.1	102	38.9	152	66.7
3	-16.1	53	11.7	103	39.4	153	67.2
4	-15.6	54	12.2	104	40.0	154	67.8
5	-15.0	55	12.8	105	40.6	155	68.3
6	-14.4	56	13.3	106	41.1	156	68.9
7	-13.9	57	13.9	107	41.7	157	69.4
8	-13.3	58	14.4	108	42.2	158	70.0
9	-12.8	59	15.0	109	42.8	159	70.6
10	-12.2	60	15.6	110	43.3	160	71.1
11	-11.7	61	16.1	111	43.9	161	71.7
12	-11.1	62	16.7	112	44.4	162	72.2
13	-10.6	63	17.2	113	45.0	163	72.8
14	-10.0	64	17.8	114	45.6	164	73.3
15	-9.4	65	18.3	115	46.1	165	73.9
16	-8.9	66	18.9	116	46.7	166	74.4
17	-8.3	67	19.4	117	47.2	167	75.0
18	-7.8	68	20.0	118	47.8	168	75.6
19	-7.2	69	20.6	119	48.3	169	76.1
20	-6.7	70	21.1	120	48.9	170	76.7
21	-6.1	71	21.7	121	49.4	171	77.2
22	-5.6	72	22.2	122	50.0	172	77.8
23	-5.0	73	22.8	123	50.6	173	78.3
24	-4.4	74	23.3	124	51.1	174	78.9
25	-3.9	75	23.9	125	51.7	175	79.4
26	-3.3	76	24.4	126	52.2	176	80.0
27	-2.8	77	25.0	127	52.8	177	80.6
28	-2.2	78	25.6	128	53.3	178	81.1
29	-1.7	79	26.1	129	53.9	179	81.7
30	-1.1	80	26.7	130	54.4	180	82.2
31	-0.6	81	27.2	131	55.0	181	82.8
32	0.0	82	27.8	132	55.6	182	83.3
33	0.6	83	28.3	133	56.1	183	83.9
34	1.1	84	28.9	134	56.7	184	84.4
35	1.7	85	29.4	135	57.2	185	85.0
36	2.2	86	30.0	136	57.8	186	85.6
37	2.7	87	30.6	137	58.3	187	86.1
38	3.3	88	31.1	138	58.9	188	86.7
39	3.9	89	31.7	139	59.4	189	87.2
40	4.4	90	32.2	140	60.0	190	87.8
41	5.0	91	32.8	141	60.6	191	88.3
42	5.6	92	33.3	142	61.1	192	88.9
43	6.1	93	33.9	143	61.7	193	89.4
44	6.7	94	34.4	144	62.2	194	90.0
45	7.2	95	35.0	145	62.8	195	90.6
46	7.8	96	35.6	146	63.3	196	91.1
47	8.3	97	36.1	147	63.9	197	91.7
48	8.9	98	36.7	148	64.4	198	92.2
49	9.4	99	37.2	149	65.0	199	92.8
50	10.0	100	37.8	150	65.5	200	93.3

6.1 Appendix A

FIGURE 6-11
MILES PER HOUR TO KILOMETERS
PER HOUR CONVERSION TABLE
1 MPH = 1.609 KM/H

MPH	KM/H	MPH	KM/H	MPH	KM/H
10	16.09	1	1.61	0.1	0.16
20	32.19	2	3.22	0.2	0.32
30	48.28	3	4.83	.03	0.48
40	64.37	4	6.44	0.4	0.64
50	80.47	5	8.05	0.5	0.80
60	96.56	6	9.66	0.6	0.97
70	112.65	7	11.27	0.7	1.13
80	128.75	8	12.87	0.8	1.29
90	144.84	9	14.48	0.9	1.45
100	160.93	10	16.09	1.0	1.61

FIGURE 6-12
U.S. GALLONS TO LITERS CONVERSION TABLE
1 U.S. GALLON = 3.785 LITERS

GAL	LITER	GAL	LITER	GAL	LITER	GAL	LITER
100	378.54	10	37.85	1	3.79	0.1	0.38
200	757.08	20	75.71	2	7.57	0.2	0.76
300	1,135.62	30	113.56	3	11.36	0.3	1.14
400	1,514.16	40	151.42	4	15.14	0.4	1.51
500	1,892.71	50	189.27	5	18.93	0.5	1.89
600	2,271.25	60	227.12	6	22.71	0.6	2.27
700	2,649.79	70	264.98	7	26.50	0.7	2.65
800	3,028.33	80	302.83	8	30.28	0.8	3.03
900	3,406.87	90	340.69	9	34.07	0.9	3.41
1,000	3,785.41	100	378.54	10	37.85	1.0	3.79

6.2 Appendix B

DISCLAIMER

HARSCO TRACK TECHNOLOGIES, HARSCO CORPORATION RECOMMENDS THAT ALL HOSE, HOSE ASSEMBLIES AND/OR FITTINGS REPLACED BY THE CUSTOMER SHOULD BE EQUAL TO OR EXCEED THE CURRENT SPECIFICATIONS OF THE ORIGINAL EQUIPMENT SUPPLIED BY HARSCO TRACK TECHNOLOGIES, HARSCO CORPORATION. HARSCO TRACK TECHNOLOGIES, HARSCO CORPORATION WILL NOT BE LIABLE FOR ANY CLAIMS OF PERSONAL INJURY RESULTING FROM THE USE OF HOSE, HOSE ASSEMBLIES AND/OR FITTINGS THAT DO NOT MEET CURRENT ORIGINAL EQUIPMENT SPECIFICATIONS. THE CUSTOMER IS ADVISED TO COMPLY WITH SAE J1273 DECEMBER 2002, RECOMMENDED PRACTICES FOR HYDRAULIC HOSE ASSEMBLIES.

 <div style="display: inline-block; vertical-align: middle; margin-left: 20px;"> <p style="margin: 0;">SURFACE VEHICLE RECOMMENDED PRACTICE</p> </div>		REV. DEC2002
	Issued 1979-09 Revised 2002-12	
	Superseding J1273 MAR2001	

Recommended Practices for Hydraulic Hose Assemblies

Foreword—This SAE Recommended Practice is intended as a guide to consider when selecting, routing, fabricating, installing, replacing, maintaining, and storing hose for fluid-power systems. It is subject to change to keep pace with experience and technical advances. For those new to hose use in fluid-power systems, this guide outlines practices to note during each phase of system design and use. Experienced designers and users skilled in achieving proper results, as well as the less experienced, can use this outline as a list of considerations to keep in mind.

Fluid power systems are complex and require extensive knowledge of both the system requirements and the various types of hose. Therefore, all-inclusive, detailed, step-by-step instructions are not practical and are beyond the scope of this document. Less experienced designers and users who need more information can consult specialists such as hose suppliers and manufacturers. This guide can improve the communication process.

Safety Considerations—These recommended practices involve safety considerations; note these carefully during all phases of design and use of hose systems. Improper selection, fabrication, installation, or maintenance of hose and hose assemblies for fluid-power systems may result in serious personal injury or property damage. These recommended practices can reduce the likelihood of component or system failure, thereby reducing the risk of injury or damage.

TABLE OF CONTENTS

1.	Scope	2
2.	References	2
3.	Explanation of Terms	2
4.	Safety Considerations	2
5.	Hose Selection and Routing	3
6.	Hose-Assembly Fabrication.....	10
7.	Hose Installation and Replacement	11
8.	Maintenance Inspection	13

SAE Technical Standards Board Rules provide that: "This report is published by SAE to advance the state of technical and engineering sciences. The use of this report is entirely voluntary, and its applicability and suitability for any particular use, including any patent infringement arising therefrom, is the sole responsibility of the user."

SAE reviews each technical report at least every five years at which time it may be reaffirmed, revised, or cancelled. SAE invites your written comments and suggestions.

Copyright ©2002 Society of Automotive Engineers, Inc.

All rights reserved. No part of this publication may be reproduced, stored in a retrieval system or transmitted, in any form or by any means, electronic, mechanical, photocopying, recording, or otherwise, without the prior written permission of SAE.

TO PLACE A DOCUMENT ORDER:

Tel: 877-606-7323 (inside USA and Canada)
 Tel: 724-776-4970 (outside USA)
 Fax: 724-776-0790
 Email: custsvc@sae.org
<http://www.sae.org>

SAE WEB ADDRESS:

SAE J1273 Revised DEC2002

9. Hose Storage..... 13
10. Notes 14

1. **Scope**—SAE J1273 provides guidelines for selection, routing, fabrication, installation, replacement, maintenance, and storage of hose and hose assemblies for fluid-power systems. Many of these SAE Recommended Practices also may be suitable for other hoses and systems.

2. **References**

2.1 **Applicable Publications**—The following publications form a part of this specification to the extent specified herein. Unless otherwise specified, the latest issue of SAE publications shall apply.

2.1.1 SAE PUBLICATIONS—Available from SAE, 400 Commonwealth Drive, Warrendale, PA 15096-0001.

SAE J343—Test and Procedures for SAE 100 R Series Hydraulic Hose and Hose Assemblies

SAE J514—Hydraulic Tube Fittings

SAE J517—Hydraulic Hose

SAE J1927—Cumulative Damage Analysis for Hydraulic Hose Assemblies

2.1.2 ISO PUBLICATION—Available from ANSI, 25 West 43rd Street, New York, NY 10036-8002.

ISO 3457—Earth moving machinery—Guards and shields—Definitions and specifications

3. **Definitions**—These explanations serve only to clarify this document and are not intended to stand alone. They are presented sequentially, with the former helping to explain the latter.

3.1 **Fluid Power**—Energy transmitted and controlled using pressurized hydraulic fluids or compressed air.

3.2 **Hose**—Flexible conductor. In this document, the term hose also may refer to a hose assembly with related accessories used in fluid power applications.

3.3 **Hose Fitting or Fitting**—Connector which can be attached to the end of a hose.

3.4 **Hose Assembly**—Hose with hose fittings attached.

3.5 **Hose Failure**—Occurrence in which a hose stops meeting system requirements.

3.6 **Hose Service Life**—Length of time a hose meets system requirements without needing replacement.

4. **Safety Considerations**—Listed in 4.1 to 4.7 are some potential conditions and situations that may lead to personal injury and/or property damage. This list is not necessarily all inclusive. Consider reasonable and feasible means, including those described in this section, to reduce the risk of injuries or property damage.

Training, including the information in this document, for operators, maintenance personnel, and other individuals working with hoses under pressure is encouraged.

4.1 **Fluid Injections**—Fine streams of escaping pressurized fluid can penetrate skin and enter a human body. These fluid injections may cause severe tissue damage and loss of limb.

Consider various means to reduce the risk of fluid injections, particularly in areas normally occupied by operators. Consider careful routing, adjacent components, warnings, guards, shields, and training programs.

SAE J1273 Revised DEC2002

Relieve pressure before disconnecting hydraulic or other lines. Tighten all connections before applying pressure.

Avoid contact with escaping fluids. Treat all leaks as though pressurized and hot enough to burn skin. Never use any part of your body to check a hose for leaks.

If a fluid-injection accident occurs, see a doctor immediately. **DO NOT DELAY OR TREAT AS A SIMPLE CUT!** Any fluid injected into the skin must be surgically removed *within a few hours* or gangrene may result. Doctors unfamiliar with this type of injury should consult a knowledgeable medical source.

- 4.2 Whipping Hose**—If a pressurized hose assembly blows apart, the fittings can be thrown off at high speed, and the loose hose can flail or whip with great force. This is particularly true in compressible-fluid systems.

When this risk exists, consider guards and restraints to protect against injury.

- 4.3 Burns from Conveyed Fluids**—Fluid-power media may reach temperatures that can burn human skin. If there is risk of burns from escaping fluid, consider guards and shields to prevent injury, particularly in areas normally occupied by operators.

- 4.4 Fire and Explosions from Conveyed Fluids**—Most fluid-power media, including fire-resistant hydraulic fluids, will burn under certain conditions. Fluids which escape from pressurized systems may form a mist or fine spray which can flash or explode upon contact with an ignition source.

Consider selecting, guarding, and routing hose to minimize the risk of combustion (see Section 5 and ISO 3457).

- 4.5 Fire and Explosions from Static-Electric Discharge**—Fluid passing through hose can generate static electricity, resulting in static-electric discharge. This may create sparks that can ignite system fluids or gases in the surrounding atmosphere.

When this potential exists, select hose specifically designed to carry the static-electric charge to ground.

- 4.6 Electrical Shock**—Electrocution could occur if hose conducts electricity through a person. Most hoses are conductive. Many contain metal or have metal fittings. Even nonconductive hoses can be conduits for electricity if they carry conductive fluids.

Be aware of routing or using hose near electrical sources. When this cannot be avoided, select appropriate hose. Nonconductive hoses should be considered. SAE J517—100R7 and 100R8 hoses, with orange covers marked "Nonconductive" are available for applications requiring nonconductive hose.

- 4.7 Mechanisms Controlled by Fluid Power**—Mechanisms controlled by fluids in hoses can become hazardous when a hose fails. For example, when a hose bursts, objects supported by fluid pressure may fall, or vehicles or machines may lose their brakes or steering.

If mechanisms are controlled by fluid power, consider safe modes of failure that minimize risks of injury or damage.

- 5. Hose Selection and Routing**—A wide variety of interacting factors influence hose service life and the ability of each fluid-power system to operate satisfactorily, and the combined effects of these factors on service life are often unpredictable. Therefore, these documents should not be construed as design standards. For applications outside the specifications in SAE J517, SAE J514, or other relevant design standards, performance of hose assemblies should be determined by appropriate testing.

SAE J1273 Revised DEC2002

Carefully analyze each system. Then design routings and select hose and related components to meet the system-performance and hose-service-life requirements, and to minimize the risks of personal injury and/or property damage. Consider the following factors:

- 5.1 System Pressures**—Excessive pressure can accelerate hose assembly failure. Analyze the steady-state pressures, and the frequency and amplitude of pressure surges, such as pulses and spikes. These are rapid and transient rises in pressure which may not be indicated on many common pressure gages and can be identified best on high-frequency-response electronic measuring instruments.

For maximum hose service life, hose selection should be based on a system pressure, including surges, that is less than the hose maximum working pressure. Hose may be used above its maximum working pressure where reduced life expectancy is acceptable. SAE J1927 provides one method to help predict wire-reinforced hose service life for a given hydraulic application, where the surge pressure peaks vary, and/or the highest pressure peaks occur infrequently.

- 5.2 Suction**—For suction applications, such as inlet flow to pumps, select hose to withstand both the negative and positive pressures the system imposes on the hose.
- 5.3 External Pressure**—In certain applications, such as in autoclaves or under water, the external environmental pressures may exceed the fluid pressure inside the hose. In these applications, consider the external pressures, and if necessary, consult the manufacturers.
- 5.4 Temperature**—Exceeding hose temperature ratings may significantly reduce hose life. Select hose so the fluid and ambient temperatures, both static and transient, fall within the hose ratings. The effects of external heat sources should not raise the temperature of the hose above its maximum operating temperature. Select hose, heat shields, sleeving, and other methods for these requirements, and route or shield hose to avoid hose damage from external heat sources.
- 5.5 Permeation**—Permeation, or effusion, is seepage of fluid through the hose. Certain materials in hose construction are more permeable than others. Consider the effects of permeation when selecting hose, especially with gaseous fluids. Consult the hose and fluid manufacturers for permeability information.
- 5.6 Hose-Material Compatibility**—Variables that can affect compatibility of system fluids with hose materials include, but are not limited to:

- a. Fluid pressure
- b. Temperature
- c. Concentration
- d. Duration of exposure

Because of permeation (see 5.5), consider compatibility of system fluids with the hose, tube, cover, reinforcement, and fittings. Consult the fluid and hose manufacturers for compatibility information.

NOTE— Many fluid/elastomer compatibility tables in manufacturers' catalogs show ratings based on fluids at 21 °C, room temperature. These ratings may change at other temperatures. Carefully read the notes on the compatibility tables, and if in doubt, consult the manufacturer.

SAE J1273 Revised DEC2002

5.7 Environment—Environmental conditions can cause hose and fitting degradation. Conditions to evaluate include, but are not limited to:

- a. Ultraviolet light
- b. Salt water
- c. Air pollutants
- d. Temperature (see 5.4)
- e. Ozone
- f. Chemicals
- g. Electricity
- h. Abrasion

If necessary, consult the manufacturers for more information.

5.8 Static-Electric Discharge—Fluid passing through hose can generate static electricity resulting in static-electric discharge. This may create sparks that can puncture hose. If this potential exists, select hose with sufficient conductivity to carry the static-electric charge to ground.

5.9 Sizing—The power transmitted by pressurized fluid varies with pressure and rate of flow. Select hose with adequate size to minimize pressure loss, and to avoid hose damage from heat generation or excessive velocity. Conduct calculations, or consult the manufacturers for sizing at flow velocities.

5.10 Unintended Uses—Hose assemblies are designed for the internal forces of conducted fluids. Do not pull hose or use it for purposes that may apply external forces for which the hose or fittings were not designed.

5.11 Specifications and Standards—When selecting hose and fittings for specific applications, refer to applicable government, industry, and manufacturer's specifications and standards.

5.12 Unusual Applications—Applications not addressed by the manufacturer or by industry standards may require special testing prior to selecting hose.

5.13 Hose Cleanliness—The cleanliness requirements of system components, other than hose, will determine the cleanliness requirements of the application. Consult the component manufacturers' cleanliness information for all components in the system. Hose assemblies vary in cleanliness levels; therefore, specify hose assemblies with adequate cleanliness for the system.

5.14 Hose Fittings—Selection of the proper hose fittings for the hose and application is essential for proper operation and safe use of hose and related assembly equipment. Hose fittings are qualified with the hose. Therefore, select only hose fittings compatible with the hose for the applications.

Improper selection of hose fittings or related assembly equipment for the application can result in injury or damage from leaks, or from hose assemblies blowing apart (see 4.2, 6.2, 6.3, and 6.4).

5.15 Vibration—Vibration can reduce hose service life. If required, conduct tests to evaluate the frequency and amplitude of system vibration. Clamps or other means may be used to reduce the effects of vibration. Consider the vibration requirements when selecting hose and predicting service life.

5.16 Hose Cover Protection—Protect the hose cover from abrasion, erosion, snagging, and cutting. Special abrasion-resistant hoses and hose guards are available for additional protection. Route hose to reduce abrasion from hose rubbing other hose or objects that may abrade it. (See Figure 1)

SAE J1273 Revised DEC2002

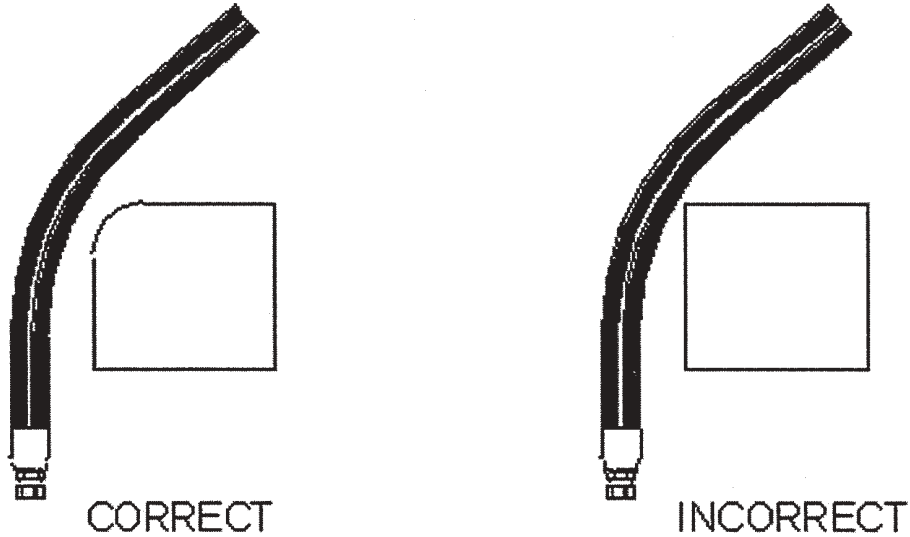

FIGURE 1—PREVENTION OF EXTERNAL DAMAGE

5.17 External Physical Abuse—Route hose to avoid:

- a. Tensile loads
- b. Side loads
- c. Flattening
- d. Thread damage
- e. Kinking
- f. Damage to sealing surfaces
- g. Abrasion
- h. Twisting

5.18 Swivel-Type Adapters—Swivel-type fittings or adapters do not transfer torque to hose while being tightened. Use these as needed to prevent twisting during installation.

5.19 Live Swivels—If two components in the system are rotating in relation to each other, live swivels may be necessary. These connectors reduce the torque transmitted to the hose.

5.20 Slings and Clamps—Use slings and clamps to support heavy or long hose and to keep it away from moving parts. Use clamps that prevent hose movement that will cause abrasion.

5.21 Minimum Bend Radius—The minimum bend radius is defined in SAE J343 and is specified in other SAE standards and hose manufacturer's product literature. Routing at less than minimum bend radius may reduce hose life. Sharp bending at the hose/fitting juncture may result in leaking, hose rupturing, or the hose assembly blowing apart (see 4.2 and Figures 2A and 2B).

SAE J1273 Revised DEC2002

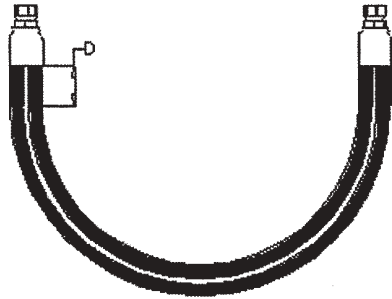

CORRECT



INCORRECT

FIGURE 2A—MINIMUM BEND RADIUS

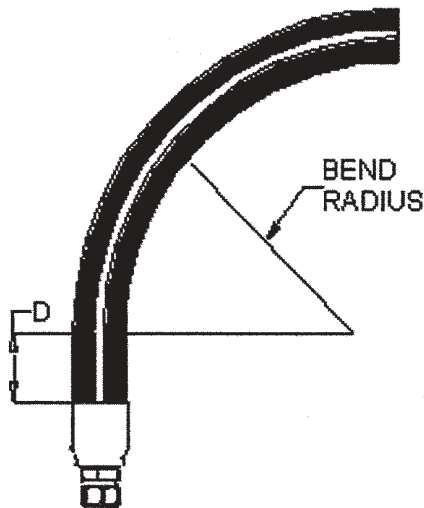

CORRECT

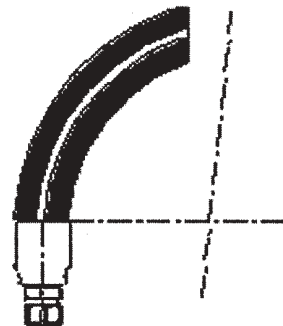

INCORRECT

FIGURE 2B—MINIMUM BEND RADIUS

SAE J1273 Revised DEC2002

5.22 Elbows and Adapters—In special cases, use elbows or adapters to relieve hose strain (see Figure 3).

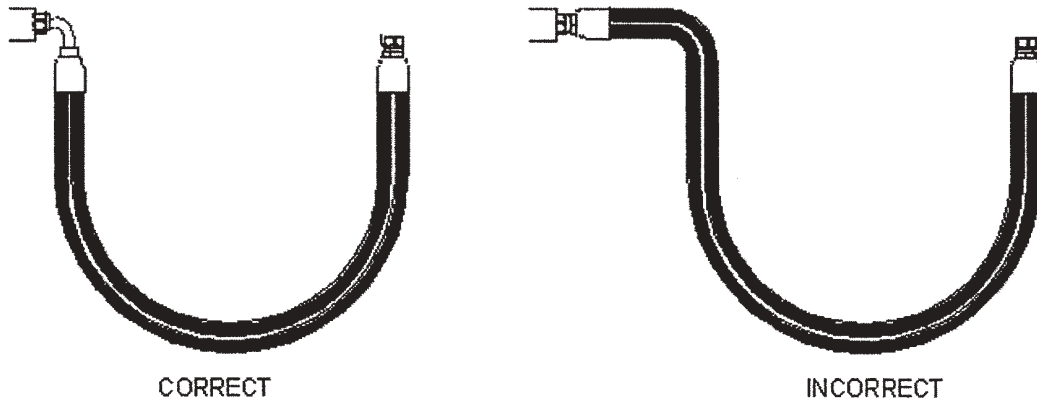

FIGURE 3—ELBOWS AND ADAPTERS

5.23 Lengths—Unnecessarily long hose can increase pressure drop and affect system performance. When pressurized, hose that is too short may pull loose from its fittings, or stress the fitting connections, causing premature metallic or seal failures. When establishing hose length, refer to Figures 4, 5, and 6; and use the following practices:

5.23.1 MOTION ABSORPTION—Provide adequate hose length to distribute movement and prevent bends smaller than the minimum bend radius.

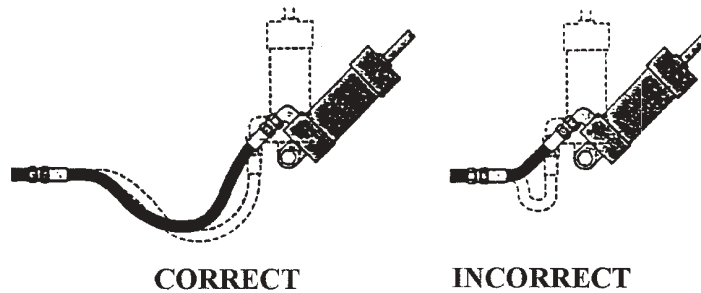

FIGURE 4—MOTION ABSORPTION

5.23.2 HOSE AND MACHINE TOLERANCES—Design hose to allow for changes in length due to machine motion and tolerances.

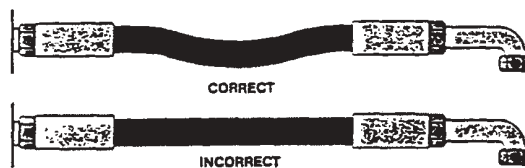

FIGURE 5—HOSE AND MACHINE TOLERANCES

6

SAE J1273 Revised DEC2002

5.23.3 HOSE LENGTH CHANGE DUE TO PRESSURE—Design hose to accommodate length changes from changing pressures. Do not cross or clamp together high- and low-pressure hoses. The difference in length changes could wear the hose covers.

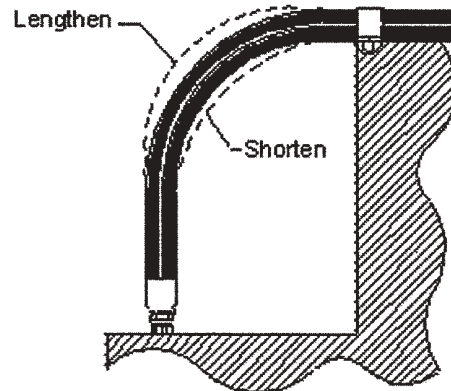

FIGURE 6—HOSE LENGTH CHANGE DUE TO PRESSURE

5.24 Hose Movement and Bending—Hose allows relative motion between system components. Analyze this motion when designing hose systems. The number of cycles per day may significantly affect hose life. Also avoid multiple planes of motion and twisting motion. Consider the motion of the hose when selecting hose and predicting service life. In applications that require hose to move or bend, refer to Figures 7A, 7B, and 8; and use these practices:

5.24.1 BEND IN ONLY ONE PLANE TO AVOID TWISTING

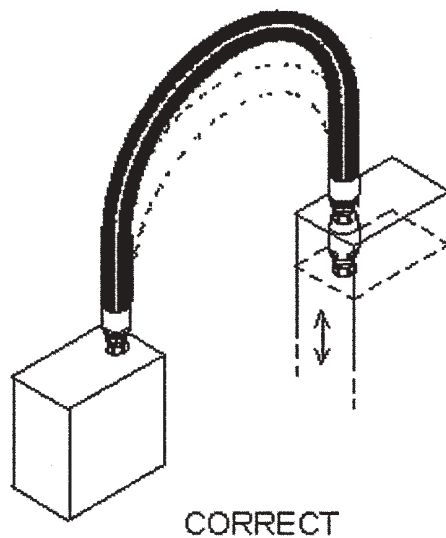

FIGURE 7A—BEND IN ONLY ONE PLANE TO AVOID TWISTING

SAE J1273 Revised DEC2002

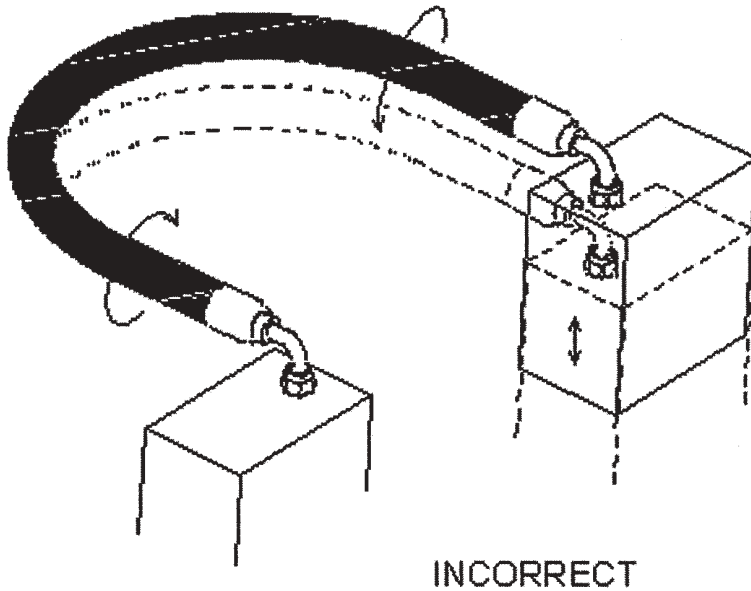

FIGURE 7B—BEND IN ONLY ONE PLANE TO AVOID TWISTING

5.24.2 PREVENT HOSE BENDING IN MORE THAN ONE PLANE—If hose follows a compound bend, couple it into separate segments, or clamp it into segments that flex in only one plane.

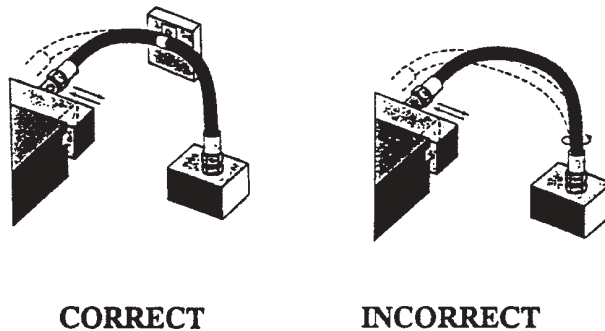

FIGURE 8—PREVENT HOSE BENDING IN MORE THAN ONE PLANE

6. **Hose-Assembly Fabrication**—Persons fabricating hose assemblies should be trained in the proper use of equipment and materials. The manufacturers' instructions and the practices listed as follows must be followed. Properly assembled fittings are vital to the integrity of a hose assembly. Improperly assembled fittings can separate from the hose and may cause serious injury or property damage from whipping hose, or from fire or explosion of vapor expelled from the hose.

SAE J1273 Revised DEC2002

6.1 Component Inspection—Prior to assembly, examine components for:

- a. Style or type
- b. Cleanliness
- c. Loose covers
- d. Nicks
- e. Size
- f. Inside obstructions
- g. Visible defects
- h. Damage
- i. Length
- j. Blisters
- k. Burrs

6.2 Hose Fittings—Hose fitting components from one manufacturer are not usually compatible with fitting components supplied by another manufacturer. For example, do not use a hose fitting nipple from one manufacturer with a hose socket from another manufacturer.

It is the responsibility of the fabricator to consult the manufacturer's written instructions or the manufacturer directly for information on proper fitting components.

6.3 Hose and Fitting Compatibility—Care must be taken to determine proper compatibility between the hose and fitting. Base selection on the manufacturers' recommendations substantiated by testing to industry standards such as SAE J517. Hose from one manufacturer is not usually compatible with fittings from another. Do not intermix hose and fittings from two manufacturers without approval from both manufacturers.

6.4 Hose Assembly Equipment—Assembly equipment from one manufacturer is usually not interchangeable with that from another manufacturer. Hoses and fittings from one manufacturer should not generally be assembled with the equipment of another manufacturer.

6.5 Safety Equipment—During fabrication, use proper safety equipment, including eye protection, breathing apparatus, and adequate ventilation.

6.6 Reuse of Hose and Fittings—When fabricating hose assemblies, do **not** reuse:

- a. Field-attachable fittings that have blown or pulled off hose
- b. Any part of hose fittings that were permanently crimped or swaged to hose
- c. Hose that has been in service after system checkout (see 7.7)

6.7 Cleanliness of Hose Assemblies—Hose assemblies may be contaminated during fabrication. Clean hoses to specified cleanliness levels (see 5.13).

7. Hose Installation and Replacement—Use the following practices when installing hose assemblies in new systems or replacing hose assemblies in existing systems:

7.1 Pre-Installation Inspection—Before installing hose assemblies, examine:

- a. Hose length and routing for compliance with original design
- b. Assemblies for correct style, size, length, and visible nonconformities
- c. Fitting sealing surfaces for burrs, nicks, or other damage

NOTE— When replacing hose assemblies in existing systems, verify that the replacement is of equal quality to the original assembly.

SAE J1273 Revised DEC2002

- 7.2 **Handling During Installation**—Handle hose with care during installation. Kinking hose, or bending at less than minimum bend radius may reduce hose life. Avoid sharp bending at the hose/fitting juncture (see 5.21).
- 7.3 **Twist Angle and Orientation**—Pressure applied to a twisted hose may shorten the life of the hose or loosen the connections. To avoid twisting, use the hose lay line or marking as a reference (see Figure 9).

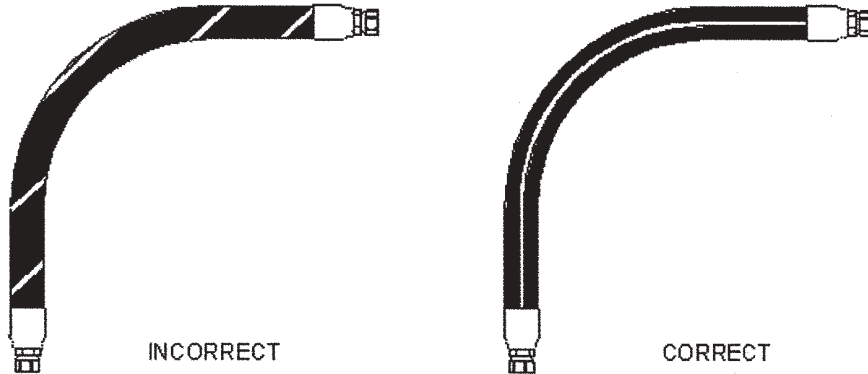

FIGURE 9—TWIST ANGLE AND ORIENTATION

- 7.4 **Securement and Protection**—Install necessary restraints and protective devices. Determine that such devices do not create additional stress or wear points.
- 7.5 **Routing**—Review proper routing practices provided in Section 5 and make appropriate corrections to obtain optimum performance.
- 7.6 **Assembly Torque**—The connection end of a hose fitting is normally threaded to obtain a tight pressure seal when attached to a port, an adapter, or another fitting. Sometimes bolts or screws provide the threaded connection. Each size and type of connection requires different torque values, and these may vary due to type of material or exterior coating.

Follow appropriate torquing instructions to obtain a proper pressure seal without over-torquing. A properly calibrated torque wrench should be used to tighten each connection, except when the manufacturer specifies tightening a specified number of hex flat turns beyond finger tight to obtain a seal.

- 7.7 **System Checkouts**—In hydraulic or other liquid systems, eliminate all air entrapment after completing the installation. Follow manufacturers' instructions to test the system for possible malfunctions and leaks.
 - 7.7.1 To avoid injury during system checkouts:
 - a. Do not touch any part of the system when checking for leaks (see 4.1).
 - b. Stay out of potentially hazardous areas while testing hose systems (see Section 4).
 - c. Relieve system pressure before tightening connections.

SAE J1273 Revised DEC2002

8. Maintenance Inspection—A hose and fitting maintenance program may reduce equipment downtime, maintain peak operating performance, and reduce the risk of personal injury and/or property damage. The user should design and implement a maintenance program that suits the specific application and each specific hose in that application.

8.1 Inspection Frequency—Evaluate factors such as the nature and severity of the application, past history, and manufacturers' information to establish the frequency of visual inspections and functional tests.

8.2 Visual Inspection (Hose and Fittings)—Visually inspect hose and fittings for:

- a. Leaks at hose fitting or in hose
- b. Damaged, cut, or abraded cover
- c. Exposed reinforcement
- d. Kinked, crushed, flattened, or twisted hose
- e. Hard, stiff, heat cracked, or charred hose
- f. Blistered, soft, degraded, or loose cover
- g. Cracked, damaged, or badly corroded fittings
- h. Fitting slippage on hose
- i. Other signs of significant deterioration

If any of these conditions exist, evaluate the hose assemblies for correction or replacement.

8.3 Visual Inspection (All Other Components)—When visually inspecting hose and fittings, inspect for related items including:

- a. Leaking ports
- b. Damaged or missing hose clamps, guards, or shields
- c. Excessive dirt and debris around hose
- d. System fluid: level, type, contamination, condition, and air entrainment

If any of these are found, address them appropriately.

8.4 Functional Test—Functional tests determine if systems with hose are leak free and operating properly. Carry out functional tests per information from equipment manufacturers.

9. Hose Storage—Age control and the manner of storage can affect hose life. Use the following practices when storing hose.

9.1 Age Control—Maintain a system of age control to determine that hose is used before its shelf life has expired. Shelf life is the period of time when it is reasonable to expect the hose to retain full capabilities for rendering the intended service.

Store hose in a manner that facilitates age control and first-in, first-out usage based on manufacturing date on hose or hose assembly. Per SAE J517:

- a. Shelf life of rubber hose in bulk form, or in hose assemblies passing visual inspection and proof test, is forty quarters (ten years) from the date of vulcanization.
- b. Shelf life of thermoplastic and polytetrafluoroethylene hose is considered to be unlimited.

SAE J1273 Revised DEC2002

9.2 Storage—Store hose and hose assemblies in a cool, dark, dry area with the ends capped. When storing hose, take care to avoid damage that could reduce hose life, and follow the manufacturers' information for storage and shelf life. Examples of factors that can adversely affect hose products in storage are:

- a. Temperature
- b. Ozone
- c. Oils
- d. Corrosive liquids and fumes
- e. Rodents
- f. Humidity
- g. Ultraviolet light
- h. Solvents
- i. Insects
- j. Radioactive materials

If there are questions regarding the quality or usability of hose or hose assemblies, evaluate appropriately:

- a. Flex the hose to the minimum bend radius and compare it with new hose. After flexing, examine the cover and tube for cracks. If any appear, no matter how small, reject the hose.
- b. If the hose is wire reinforced, and the hose is unusually stiff, or a cracking sound is heard during flexing, check for rust by cutting away a section of the cover from a sample. Rust would be another reason for rejection.
- c. If doubt still persists, contact hose assembler to conduct proof-pressure tests or any other tests needed to verify hose quality.

10. Notes

10.1 Marginal Indicia—The (R) is for the convenience of the user in locating areas where technical revisions have been made to the previous issue of the report. If the symbol is next to the report title, it indicates a complete revision of the report.

PREPARED BY THE SAE FLUID CONDUCTORS AND CONNECTORS TECHNICAL COMMITTEE SC3—
TRAINING AND EDUCATION SUBCOMMITTEE

SAE J1273 Revised DEC2002

Rationale—SAE J1273 is being updated in order to show figures that more clearly describe the section. These updated figures have been redrawn by new equipment. Therefore the pictures clarify the task in order to accurately depict what is in the text. The figures are also positioned in order to show the “Correct” version prior to showing the “Incorrect” version. Each figure will be set up in this fashion for uniformity.

Relationship of SAE Standard to ISO Standard—Not applicable.

Application—SAE J1273 provides guidelines for selection, routing, fabrication, installation, replacement, maintenance, and storage of hose and hose assemblies for fluid-power systems. Many of these SAE Recommended Practices also may be suitable for other hoses and systems.

Reference Section

SAE J343—Test and Procedures for SAE 100 R Series Hydraulic Hose and Hose Assemblies

SAE J514—Hydraulic Tube Fittings

SAE J517—Hydraulic Hose

SAE J1927—Cumulative Damage Analysis for Hydraulic Hose Assemblies

ISO 3457—Earth moving machinery—Guards and shields—Definitions and specifications

Developed by the SAE Fluid Conductors and Connectors Technical Committee SC3—Training and Education Subcommittee

Sponsored by the SAE Fluid Conductor and Connectors Technical Committee

**SECTION 7 - PARTS
TABLE OF CONTENTS**

SERIAL NUMBERS 7 - 3

INSTRUCTIONS FOR ORDERING PARTS 7 - 4

LIMITED WARRANTY 7 - 5

PRODUCT IMPROVEMENT LIABILITY DISCLAIMER..... 7 - 5

HAZARDOUS MATERIAL DISCLAIMER 7 - 5

GUIDE WHEEL UNIT - 201492 7 - 6

GUIDE WHEEL ASSEMBLY..... 7 - 9

GUIDE WHEEL UNIT HYDRAULIC PIPING - 201492 7 - 10

STEERING LOCK GROUPS 7 - 11

RAIL SWEEP GROUP - 201580..... 7 - 12

TRUCK BRAKE CONNECTION - 162114 7 - 13

HYDRAULIC POWER PACK, FULL - 137926 7 - 14

HYDRAULIC POWER PACK, ABBREVIATED - 137927 7 - 18

SIGHT ROD EXTENSION GROUP - 164574..... 7 - 20

DECAL SERVICE GROUP - 203159 7 - 20

MOUNTING BRACKET GROUPS

 201536..... 7 - 21

 203178..... 7 - 22

Serial Numbers

When this bulletin is received, complete the following record from the serial number tag on the front guide wheel unit. Always mention these factory serial numbers when calling or writing about the unit. The serial number tag is located on the frame assembly of the unit.

FRONT GUIDE WHEEL UNIT SERIAL NUMBER

HTT Harsco Track Technologies a harsco company™		PATENT NUMBER <input type="text"/>
WHEN ORDERING PARTS FOR THIS ACCESSORY ALWAYS GIVE THE FOLLOWING INFORMATION		
Fairmont ™ HY-RAIL® GUIDE WHEEL EQUIPMENT		
SERIAL NUMBER	SYMBOL	MODEL NUMBER
<input type="text"/>	<input type="text"/>	<input type="text"/>
FAIRMONT, MN. 56031 U.S.A.		
52400K		

Instructions For Ordering Parts

1. See Section 8 for the Vehicle Application charts.
2. Find the chart for the make, model and year of the vehicle that the unit is mounted on.
3. Each application consists of required groups, optional groups required and accessory group options. These are the group numbers that were supplied with, or that were available for the unit.
4. Locate the appropriate group numbers in the Parts Section to find the individual parts required.
5. Front - rear and left - right are determined from the operator's position.
6. Assemblies: Items listed in CAPITALS are assemblies which include all parts listed immediately following and indented to the right. When assemblies can be used, always order them to save work of fitting separate parts.
7. For convenience in ordering, parts are listed by item number, part number, description, and quantity in each assembly or group. If in doubt as to any part wanted, send full description, sketch, or send the old part with the order.
8. To insure prompt and correct shipment of parts on orders, always give:
 - a. Quantity of each part wanted.
 - b. Part number of each part as shown in this book. Include any prefix and suffix letters.
 - c. Description of each part as shown in this book.
 - d. Factory serial numbers recorded above.
 - e. Purchase order number (if required).
 - f. Preferred method of shipment.
9. All parts are shipped F.O.B. factory, transportation charges to be paid by customer. Terms to be determined by the Credit Department.

Limited Warranty

HARSCO TRACK TECHNOLOGIES products are designed to give high quality service and are manufactured from high grade material, by competent workmen under careful supervision. Harsco Track Technologies, Harsco Corporation warrants products of its manufacture to be free of defects in material and workmanship, under normal use and service for a period of six (6) months from date of delivery to the original user. The obligation of Harsco Track Technologies, Harsco Corporation under this warranty is limited to repairing or replacing at its factories, or other location designated by it, any part or parts thereof which are returned within 30 days of the date when failure occurs or defect is noted, with transportation charges prepaid, and which upon examination appears to the satisfaction of Harsco Track Technologies, Harsco Corporation to have been defective. Such free repair or replacement does not include transportation charges, or the cost of installing the new part or any other expense incident thereto. Harsco Track Technologies, Harsco Corporation will not be liable for other loss, damage, or expense directly or indirectly arising from the use of its products, nor will Harsco Track Technologies, Harsco Corporation be liable for special, incidental or consequential damages.

Ordinary wear and tear, and damage from abuse, misuse, neglect or alteration are not covered by this warranty. Harsco Track Technologies, Harsco Corporation assumes no liability for expenses incurred or repairs made outside its factories except by written consent. This warranty is null and void if instructions and operating procedures are not followed.

Equipment or parts not manufactured by this company, but which are furnished in connection with HARSCO TRACK TECHNOLOGIES products, are covered directly by the warranty of the manufacturer supplying them. However, Harsco Track Technologies, Harsco Corporation will assist in obtaining adjustment on such equipment or parts when necessary.

THIS WARRANTY IS IN LIEU OF ALL OTHER WARRANTIES EXPRESSED OR IMPLIED INCLUDING ANY IMPLIED WARRANTIES OF MERCHANTABILITY OR FITNESS FOR A PARTICULAR PURPOSE AND OF ANY OTHER OBLIGATION OR LIABILITY OF HARSCO TRACK TECHNOLOGIES, HARSCO CORPORATION.

Product Improvement Liability Disclaimer

HARSCO TRACK TECHNOLOGIES, HARSCO CORPORATION RESERVES THE RIGHT TO MAKE ANY CHANGES IN OR IMPROVEMENTS ON ITS PRODUCTS WITHOUT INCURRING ANY LIABILITY OR OBLIGATION WHATEVER AND WITHOUT BEING REQUIRED TO MAKE ANY CORRESPONDING CHANGES OR IMPROVEMENTS IN PRODUCTS PREVIOUSLY MANUFACTURED OR SOLD.

Hazardous Material Disclaimer

THE PARTS/ASSEMBLIES THAT ARE USED IN THIS PRODUCT ARE CLASSIFIED AS "ARTICLES" ACCORDING TO 29 CFR 1910.1200 (C). THEY ARE FORMED TO A SPECIFIC SHAPE OR DESIGN DURING MANUFACTURE, HAVE END USE FUNCTION DEPENDENT UPON THEIR SHAPE OR DESIGN, AND DO NOT RELEASE ANY HAZARDOUS CHEMICAL UNDER NORMAL CONDITIONS OF USE. ACCORDINGLY, WE ARE NOT REQUIRED TO SUPPLY MATERIAL SAFETY DATA SHEETS (MSDS) OR TO LABEL SHIPPING CONTAINERS FOR "ARTICLES". HOWEVER, LUBRICANTS, LIQUIDS, GASEOUS CHEMICALS AND SOLIDS USED IN OPERATION OR MAINTENANCE OF THE PRODUCT MAY REQUIRE THAT USER'S TAKE OCCUPATIONAL PROTECTIVE MEASURES. MSDS SHEETS FOR SUCH MATERIALS WILL BE SUPPLIED TO YOUR PURCHASING MANAGER/SAFETY DIRECTOR TO BE USED IN YOUR EMPLOYEE SAFETY TRAINING EDUCATION AND ENVIRONMENTAL HEALTH TRAINING.

201492 GUIDE WHEEL UNIT

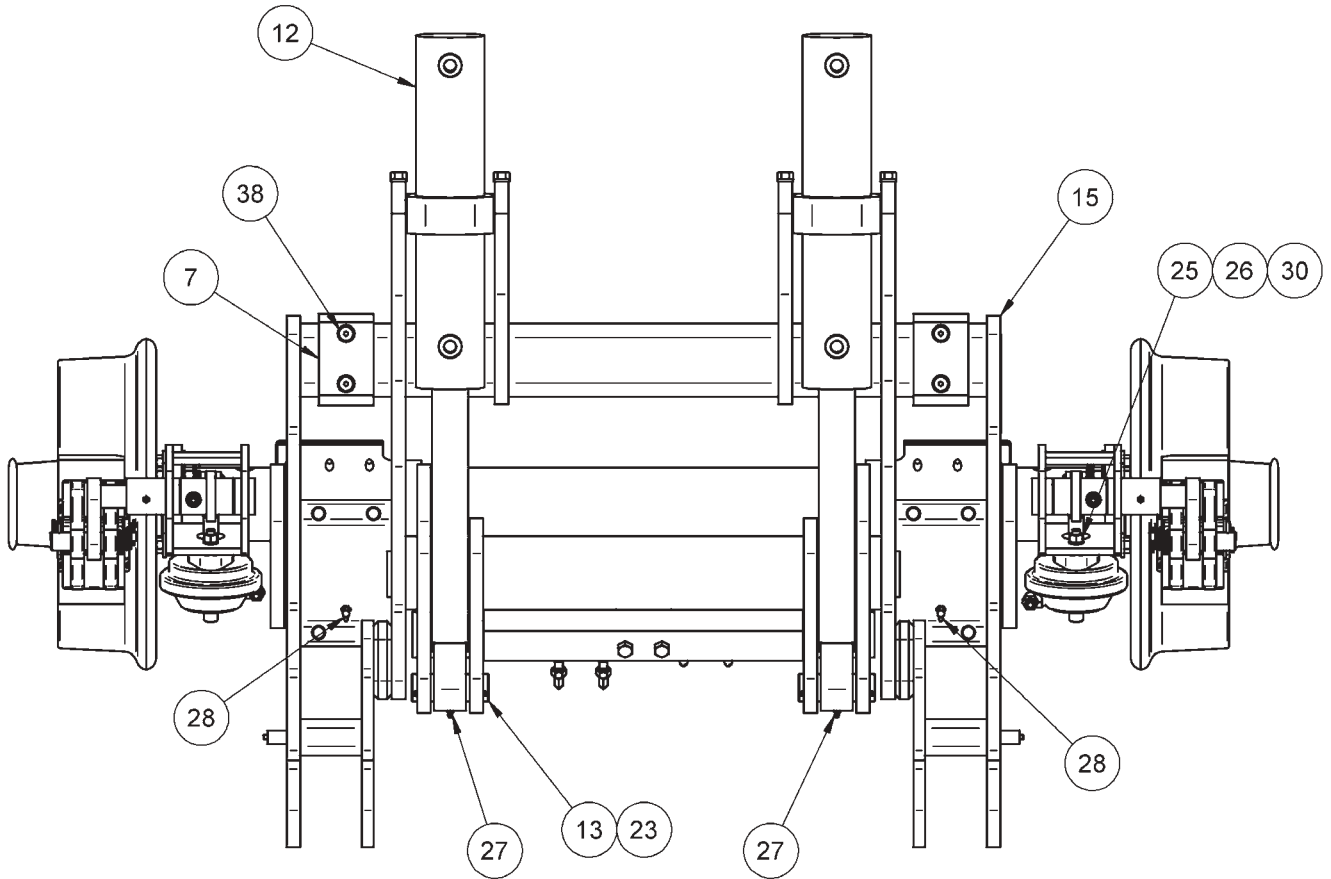

7

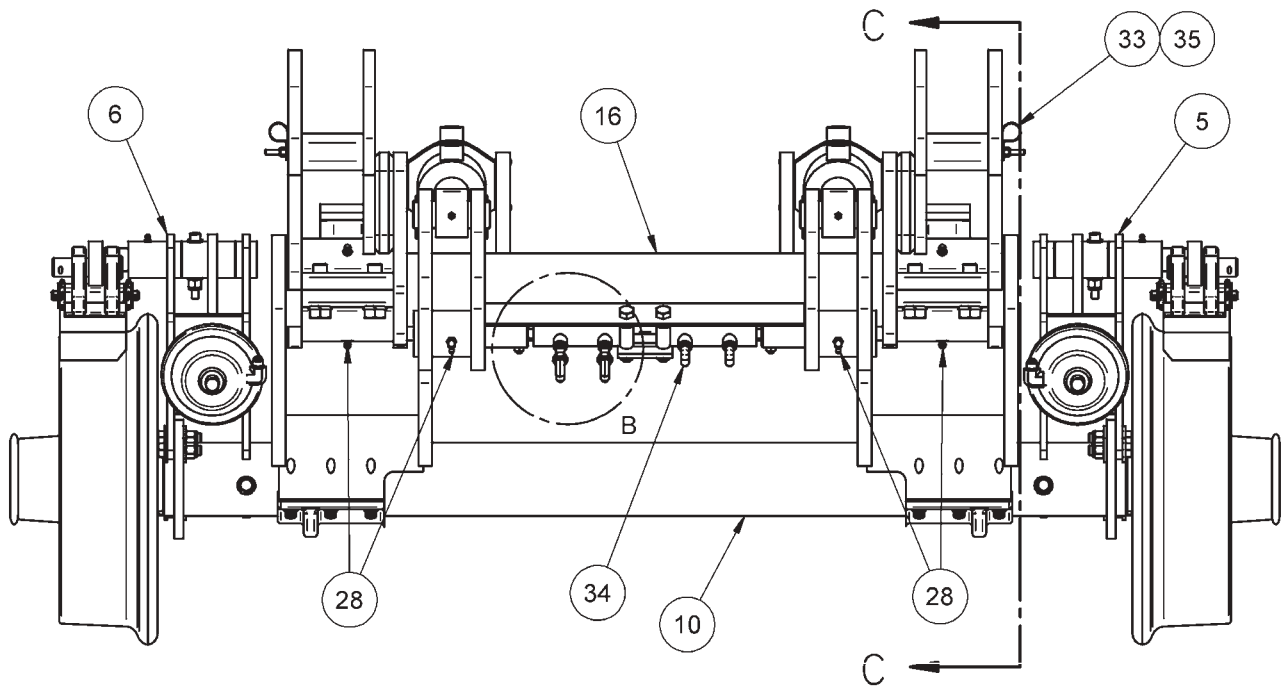

201492 GUIDE WHEEL UNIT

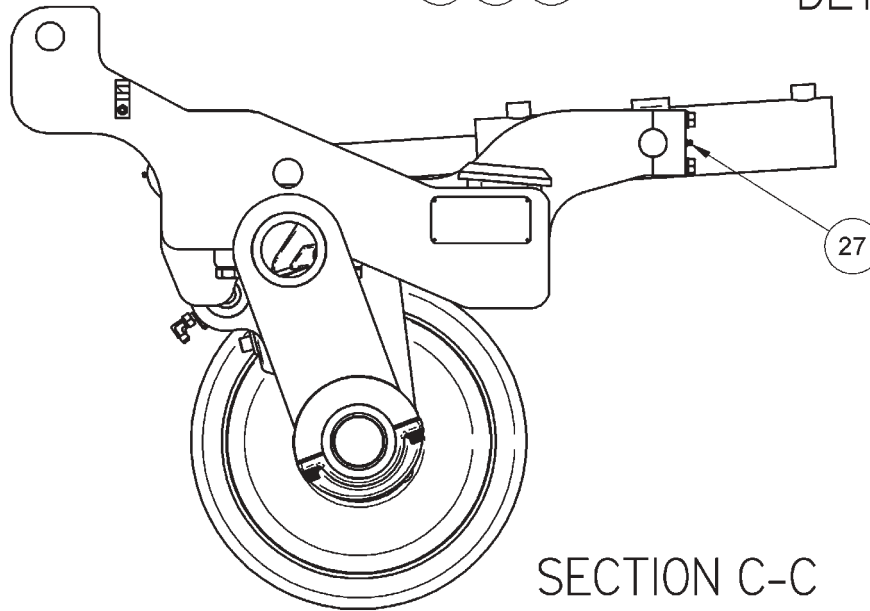
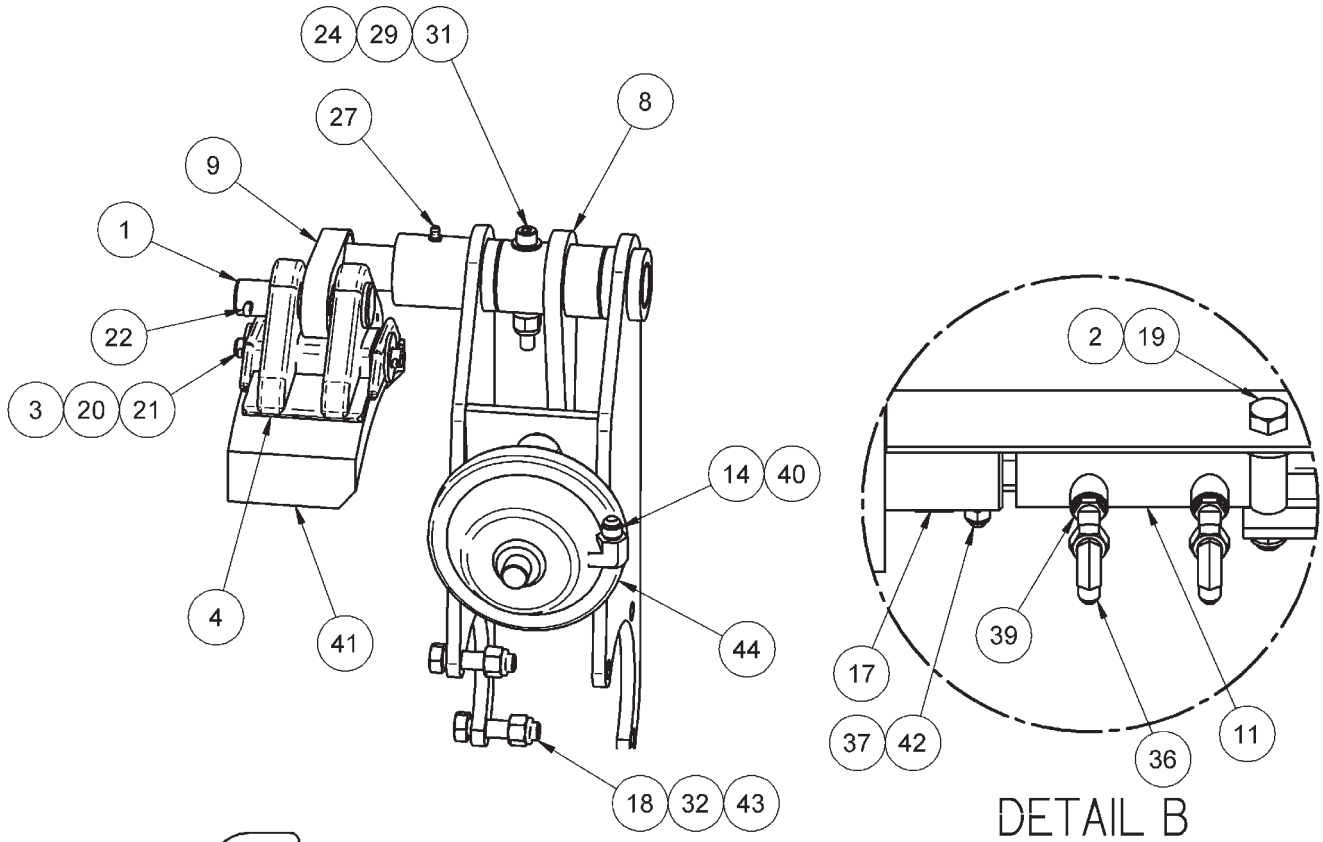

201492 GUIDE WHEEL UNIT

ITEM	PART NO	DESCRIPTION	QTY
1	070238	Pin	2
2	072897	Washer	2
3	126846	Pin	2
4	136922K	Brake Shoe Holder	2
5	157678	Brake Bracket	1
6	157679	Brake Bracket	1
7	161296	Pad	2
8	168792	Lever Assembly	2
9	168793	Pin Assembly	2
10	174351	Axle Assembly (includes nuts and cotter pins)	1
11	187099	Hydraulic Cylinder, Lock	2
12	200460	Hydraulic Cylinder, Raise / Lower	2
13	200475	Pin	2
14	201425	Hose	2
15	201511	Upper Structure	1
16	201516	Cross Tube	1
17	201541	Pin	2
18	700564200	Cap Screw, 1/2-13 x 2" GR 8 Hex Hd	6
19	700564300	Cap Screw, 1/2-13 x 3" GR 8 Hex Hd	2
20	F001104	Cotter Pin, 1/8 x 1"	4
21	F001267	Wrought Washer, 1/2"	4
22	F001324	Cotter Pin, 3/16 x 1-1/2"	2
23	F002547	Cotter Pin, 1/8 x 2"	4
24	F004600	Elastic Stop Nut, 3/8"-16	2
25	F005459	Yoke	2
26	F005460	Yoke and Pin Assembly	2
27	F008014	Grease Fitting	8
28	F009217	Grease Fitting	6
29	F009681	SAE Washer, 3/8"	4
30	F011013	Hex Jam Nut, 1/2"-20 GR 2	2
31	F013321	Cap Screw, 3/8-16 x 3-1/4" Soc Hd	2
32	F013500	Elastic Stop Nut, 1/2"	8
33	F013588	Elastic Stop Nut, 1/4"-20	2
34	F014734	90° Elbow	4
35	F014801	Hose Clamp, 1"	2
36	F015085	90° Elbow	2
37	F015616	Hex Lock Nut, 5/16"-24	2
38	F016338	Cap Screw, 3/8-16 x 1-1/2" Flt Soc Hd	4
39	F017898	Tee	2
40	F020522	90° Elbow	2
41	F022274	Brake Shoe	2
42	F023870	Cap Screw, 5/16-24 x 2" GR 8 Hex Hd	2
43	F024602	Hardened Washer	12
44	F025058	Brake Actuator	2

GUIDE WHEEL ASSEMBLY

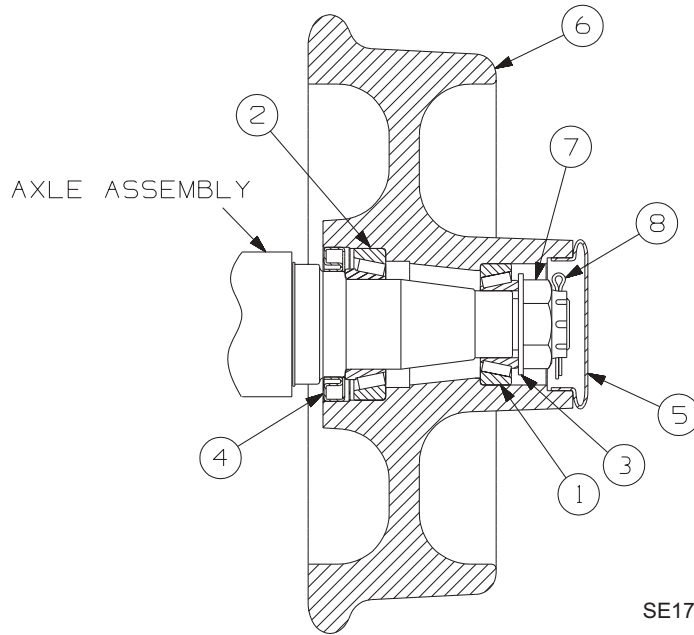

Note: Quantities listed are for one wheel only.

ITEM	PART NO	DESCRIPTION	QTY
1	159508	Bearing Cup And Cone, Outside	1
2	159507	Bearing Cup And Cone, Inside	1
3	F025049	Washer	1
4	F025057	Grease Seal	1
5	F025011	Grease Cap	1
6	175661	Wheel	1
7	F025249	Hex Slotted Nut, 1-1/2"-12	1
8	F003150	Cotter Pin, 3/16 x 2-1/2"	1

201492 GUIDE WHEEL UNIT - HYDRAULIC PIPING

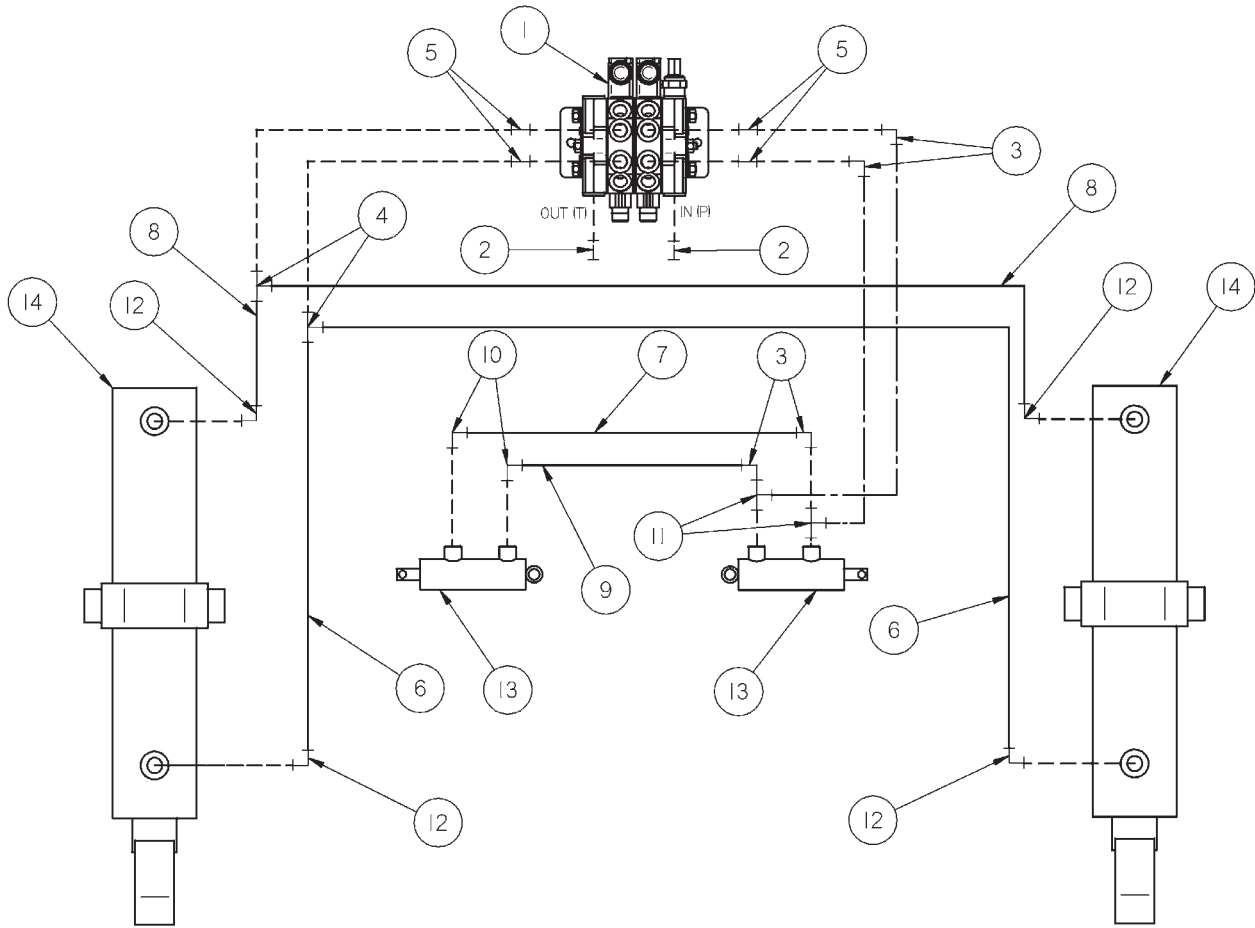

ITEM	PART NO	DESCRIPTION	QTY
	202101	HYDRAULIC VALVE GROUP	1
1	201510	Hydraulic Valve	1
2	F013326	Adapter	2
3	F015085	90° Elbow	2
4	F021905	Tee	2
5	F022230	Adapter	4
6	165976	Hose Assembly	2
7	174884	Hose Assembly	1
8	180449	Hose Assembly	2
9	189639	Hose Assembly	1
10	F014734	90° Elbow	2
11	F017898	Tee	2
12	F022262	90° Elbow	4
13	187099	Hydraulic Cylinder, Lock	2
14	200460	Hydraulic Cylinder, Raise / Lower	2

STEERING LOCK GROUPS

Individual steering lock components are not available as repair parts. Steering lock groups are sold as complete replacement groups only. See vehicle application charts to find the correct steering lock group applicable to your make, model and year of vehicle.

201580 RAIL SWEEP GROUP

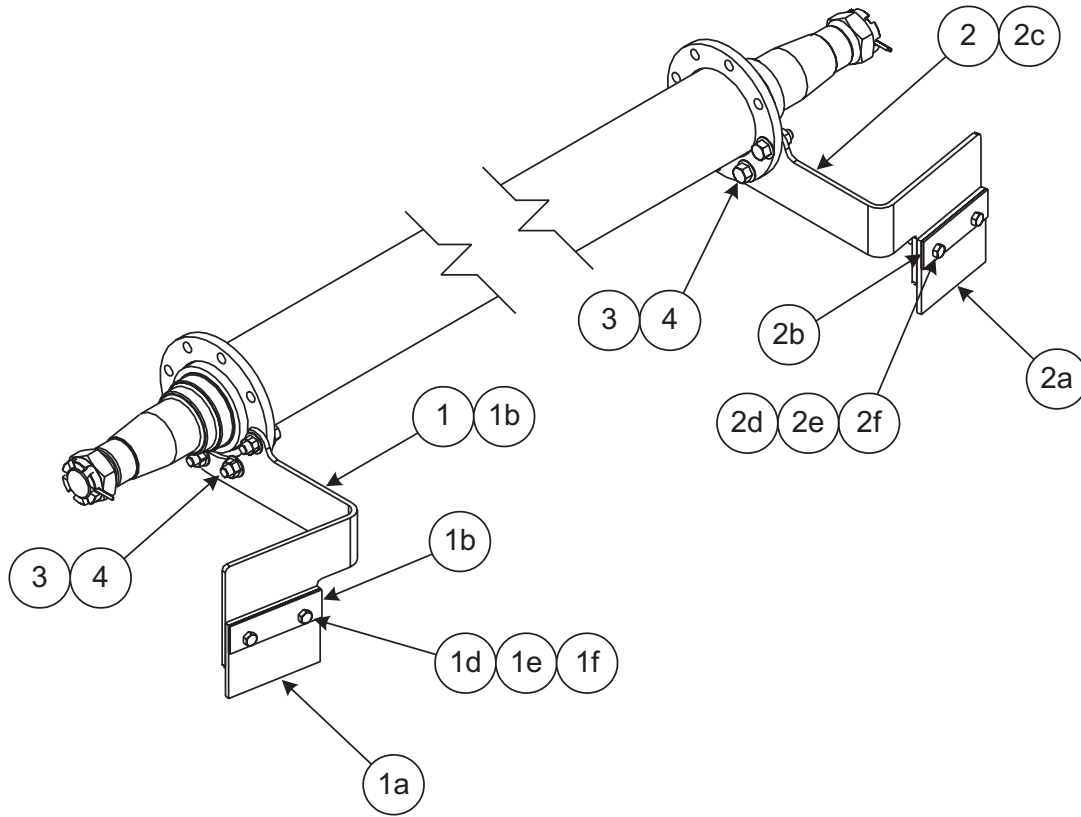

ITEM	PART NO	DESCRIPTION	QTY
	201580	RAIL SWEEP GROUP	1
1	201576	RAIL SWEEP ASSEMBLY, RIGHT	1
1a	108509K1	Rail Sweep	1
1b	108510	Rail Sweep Plate.	1
1c	201575	Rail Sweep Bracket, Right	1
1d	F001024	Cap Screw, 3/8-16 x 1-1/2" Hex Hd	2
1e	F001115	Wrought Washer, 3/8".	2
1f	F015922	Elastic Stop Nut, 3/8"-16.	2
2	201574	RAIL SWEEP ASSEMBLY, LEFT	1
2a	108509K1	Rail Sweep	1
2b	108510	Rail Sweep Plate.	1
2c	201573	Rail Sweep Bracket, Left.	1
2d	F001024	Cap Screw, 3/8-16 x 1-1/2" Hex Hd	2
2e	F001115	Wrought Washer, 3/8".	2
2f	F015922	Elastic Stop Nut, 3/8"-16.	2
3	F022037	Hex Flg Nut, 1/2"-13.	6
4	F023386	Cap Screw, 1/2-13 x 1-1/2" Hex Flg Hd	6

162114 TRUCK BRAKE CONNECTION

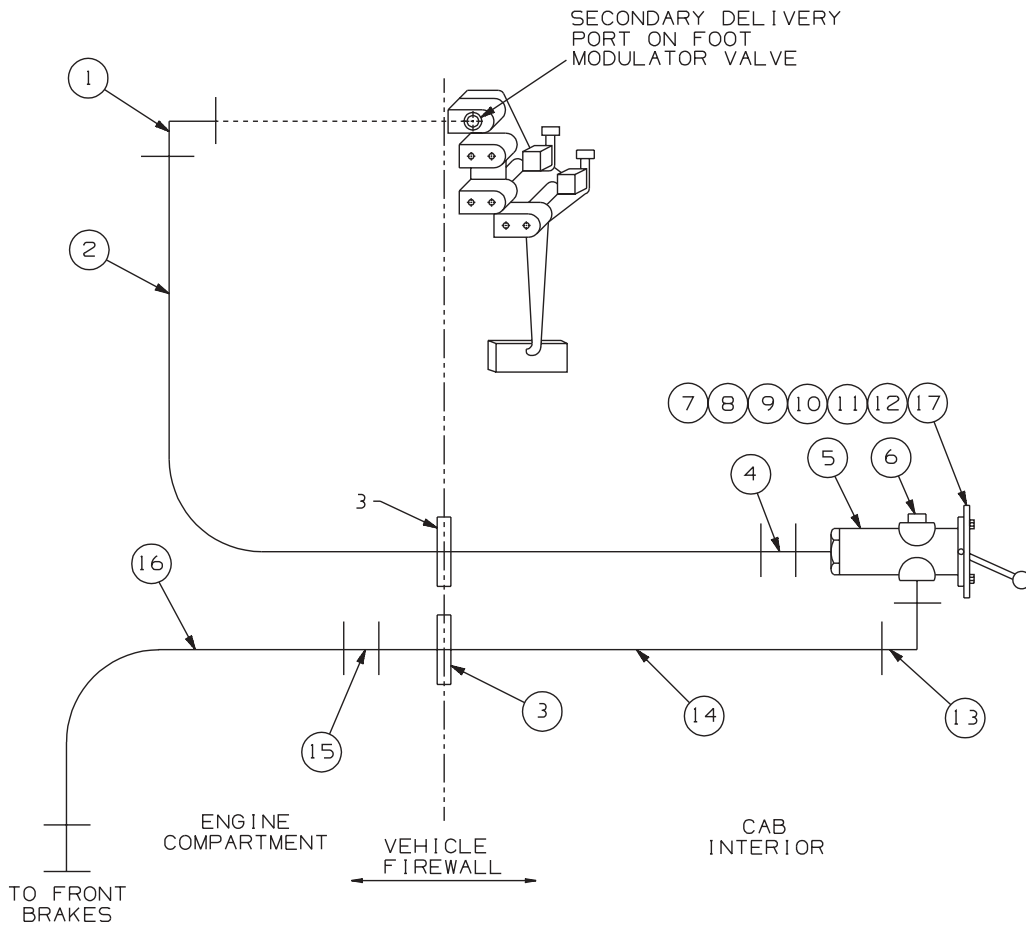

ITEM	PART NO	DESCRIPTION	QTY
	162114	TRUCK BRAKE CONNECTION.....	1
1	F012055	90° Elbow, 9/16 M JIC x 3/8 M NPT	1
2	F018904	Hose, 5/16 x 48" Swivel 9/16 F JIC Both Ends.....	1
3	F012587	Grommet.....	2
4	F010994	Adapter, 9/16 M JIC x 1/4 M NPT	1
5	F019332	Air Control Valve.....	1
6	F010989	Pipe Plug, 1/4 M NPT	1
7	120453	Bracket	1
8	F001113	Cap Screw, 5/16-18 x 1-1/4" Hex Hd	2
9	F001100	SAE Lock Washer, 5/16"	2
10	F007021	Hex Nut, 5/16"-18	2
11	122583	Instruction Plate, Rail Wheel.....	1
12	F009591	Machine Screw, #10-24 x 3/4" Rd Hd.....	2
13	F010988	90° Elbow, 9/16 M JIC x 1/4 M NPT	1
14	079235	Hose, 5/16 x 51" Swivel 9/16 F JIC Both Ends.....	1
15	F011152	Adapter, 9/16 M JIC x 9/16 M JIC.....	1
16	075540	Hose, 5/16 x 76" Swivel 9/16 F JIC Both Ends.....	1
17	120457	Decal, Rail Brake Operation.....	1

137926 HYDRAULIC POWER PACK - FULL

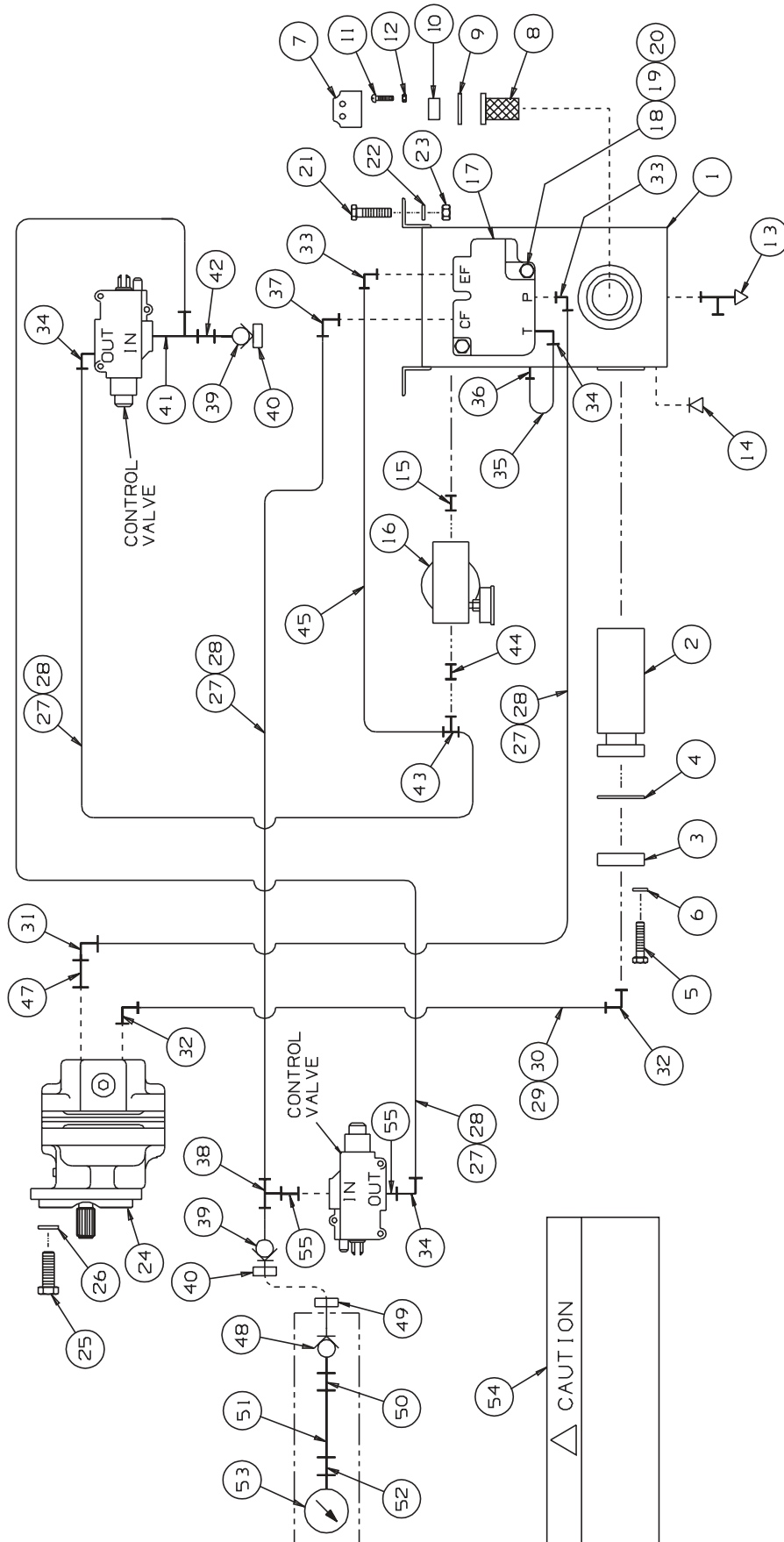

7

137926 HYDRAULIC POWER PACK - FULL

ITEM PART NO	DESCRIPTION	QTY
137926	HYDRAULIC POWER PACK -FULL	1
129136	HYDRAULIC RESERVOIR ASSEMBLY	1
1 099444	Reservoir Only	1
2 F014155	Filter	1
3 082205	Filter Flange	1
4 077997	Flange Gasket	1
5 F001125	Cap Screw, 3/8-16 x 1-1/4" Hex Hd.	4
6 F001025	SAE Lock Washer, 3/8"	4
7 F022655	FILLER CAP	1
8 F010465	Filler Screen	1
9 056780	Filler Flange Gasket	2
10 F010466	Filler Flange	1
11 F009723	Machine Screw, 10-24 x 3/8" Rd Hd	6
12 F009541	SAE Lock Washer, #10	6
13 F010181	Drain Valve, 1/8 M NPT	2
14 F012702	Pipe Plug, 3/8 M NPT Magnetic.	1
15 F001328	Pipe Nipple, 3/4 M NPT x 1-3/8"	1
16 F015452	FILTER - RETURN	1
16a F015453	Replacement Filter Element	1
17 120993	VALVE, FLOW DIVIDER	1
17a F019415	Pressure Relief Washers (set of four)	1
18 F009663	Cap Screw, 5/16-18 x 2" Hex Hd.	2
19 F007021	Hex Nut, 5/16"-18	2
20 F001100	SAE Lock Washer, 5/16"	2
21 F001125	Cap Screw, 3/8-16 x 1-1/4" Hex Hd	4
22 F001025	SAE Lock Washer, 3/8"	4
23 F007020	Hex Nut, 3/8"-16	4
24 F023330	Hydraulic Pump	1
25 F003136	Cap Screw, 1/2-13 x 1" Hex Hd	2
26 F001075	SAE Lock Washer, 1/2"	2
140344	HOSE GROUP	1
27 F009947	Hose, 13/32 x 960" (cut to length)	1
28 F020713	Hose Fitting, Swivel 3/4 F JIC (install on hose F009947)	8
29 F010298	Hose, 1-1/8 x 75" (cut to length)	1
30 F014307	Hose Fitting, Swivel 1-5/8 F JIC (install on hose F010298)	2
31 F013243	90° Elbow, 3/4 M NPT x 3/4 M JIC	1
32 F021260	90° Elbow, 1 M NPT x 1-5/8 M JIC	2
33 F012054	90° Elbow, 1/2 M NPT x 3/4 M JIC	2
34 F011114	90° Elbow, 3/8 M NPT x 3/4 M JIC	3
35 067736	Hose, 13/32 x 17" Swivel 3/4 F JIC Both Ends	1
36 F011170	Adapter, 3/8 M NPT x 3/4 M JIC	1
37 F012704	90° Elbow, 3/4 M JIC x 3/8 M NPT	1

137926 HYDRAULIC POWER PACK - FULL

ITEM	PART NO	DESCRIPTION	QTY
38	F013605	Tee, 3/4 M JIC x 3/8 M NPT x 3/8 M NPT	1
39	F015303K	Nose Piece, 3/8 F NPT	2
40	F015077	Dust Cap	2
41	F014722	Tee, 3/8 F NPT x 3/4 M JIC x 3/8 M NPT	1
42	F011604	Adapter, 3/8 M NPT x 3/8 M NPT	1
43	F013629	Tee, 3/4 M JIC x 3/4 M JIC x 3/8 M NPT	1
44	F012024	Reducer Bushing, 3/4 M NPT x 3/8 F NPT	1
45	067736	Hose, 13/32 x 17" Swivel 3/4 F JIC Both Ends	1
47	F011617	Reducer Bushing, 1 M NPT x 3/4 F NPT	1
	099137K	PRESSURE GAUGE ASSEMBLY	1
48	F015110K	Body, 3/8 F NPT	1
49	F015111	Dust Cap	1
50	F012056	Adapter, 3/8 M NPT x 9/16 M JIC	1
51	171878	Hose, 3/8 x 14" Swivel 9/16 F JIC Both Ends	1
52	F011109	Adapter, 9/16 M JIC x 1/4 F NPT	1
53	F011432K	Pressure Gauge, 1/4 M NPT	1
54	137941	Decal, Caution -Recommended...	1
55	F015103	Adapter, 3/8 F NPT x 3/4 M STR (used on vertical units only)	2

137927 HYDRAULIC POWER PACK - ABBREVIATED

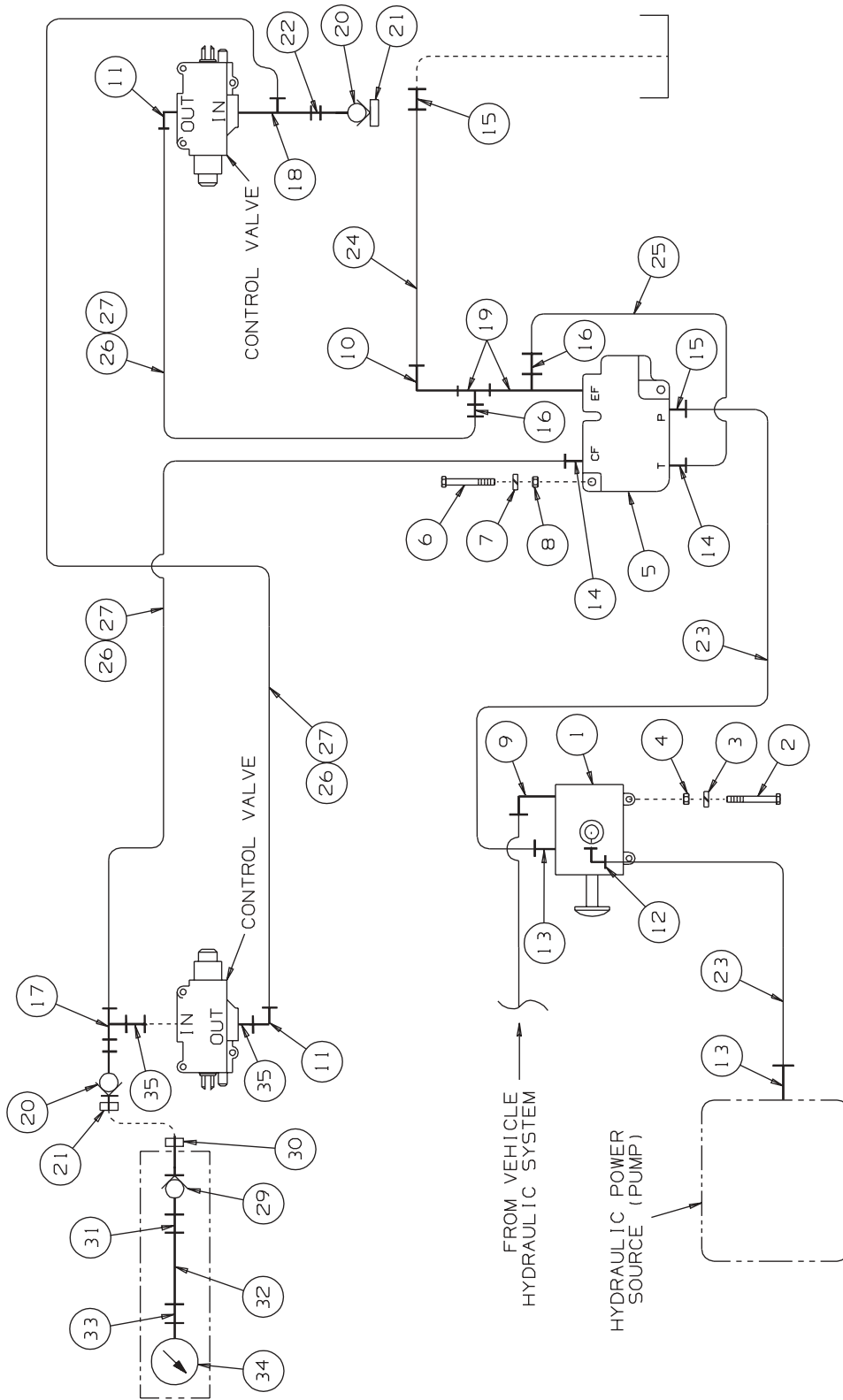

137927 HYDRAULIC POWER PACK - ABBREVIATED

ITEM	PART NO	DESCRIPTION	QTY
	137927	HYDRAULIC POWER PACK -ABBREVIATED	1
1	F016490	Selector Valve	1
2	F002760	Cap Screw, 3/8-16 x 2-1/4" Hex Hd	2
3	F001025	SAE Lock Washer, 3/8"	2
4	F009670	Hex Grip Nut, 3/8"-16	2
5	120993	VALVE, FLOW DIVIDER	1
	F019415	Pressure Relief Washers (set of four)	1
6	F009663	Cap Screw, 5/16-18 x 2" Hex Hd	2
7	F001100	SAE Lock Washer, 5/16"	2
8	F007021	Hex Nut, 5/16"-18	2
9	F012010	90° Elbow Street, 3/4 F NPT x 3/4 M NPT	1
10	F010584	90° Elbow, 1-1/16 M JIC x 1/2 M NPT	1
11	F011114	90° Elbow, 3/4 M JIC x 3/8 M NPT	2
12	F010586	90° Elbow, 1-1/16 M JIC x 3/4 M NPT	1
13	F010581	Adapter, 1-1/16 M JIC x 3/4 M NPT	2
14	F011170	Adapter, 3/4 M JIC x 3/8 M NPT	2
15	F013210	Adapter, 1-1/16 M JIC x 1/2 M NPT	2
16	F012027	Adapter, 3/4 M JIC x 1/2 M NPT	2
17	F013605	Tee, 3/4 M JIC x 3/8 M NPT x 3/8 M NPT	1
18	F014722	Tee, 3/8 F NPT x 3/4 M JIC x 3/8 M NPT	1
19	F010692	Tee, 1/2 F NPT x 1/2 M NPT x 1/2 F NPT	2
20	F015303K	Nose Piece, 3/8 F NPT	2
21	F015077	Dust Cap	2
22	F011604	Adapter, 3/8 M NPT x 3/8 M NPT	1
23	071692	Hose, 5/16 x 48" Swivel 1-1/16 F JIC Both Ends	2
24	111100	Hose, 3/4 x 28" Swivel 1-1/16 F JIC Both Ends	1
25	071867	Hose, 1/2 x 19-3/4" Swivel 3/4 F JIC Both Ends	1
	140345	HOSE GROUP	1
26	F009947	Hose, 13/32 x 960" (cut to length)	1
27	F020713	Hose Fitting, Swivel 3/4 F JIC (install on hose F009947)	6
	099137K	PRESSURE GAUGE ASSEMBLY	1
29	F015110K	Body, 3/8 F NPT	1
30	F015111	Dust Cap	1
31	F012056	Adapter, 3/8 M NPT x 9/16 M JIC	1
32	171878	Hose, 3/8 x 14" Swivel 9/16 F JIC Both Ends	1
33	F011109	Adapter, 9/16 M JIC x 1/4 F NPT	1
34	F011432K	Pressure Gauge, 1/4 M NPT	1
35	F015103	Adapter, 3/8 F NPT x 3/4 M STR (used on vertical units only)	2

164574 SIGHT ROD EXTENSION GROUP

PART NO	DESCRIPTION	QTY
164574	SIGHT ROD EXTENSION GROUP	1
130195	Sight Rod Kit (includes two sight rods)	1
135809	Sight Rod Extension	2
161855	Mounting Bar	2
F022036	Cap Screw, 1/2-13 x 1-1/4" Hex Flg Hd	2
F022037	Hex Flg Nut, 1/2"-13	2

203159 DECAL SERVICE GROUP

PART NO	DESCRIPTION	QTY
203159	DECAL SERVICE GROUP	1
F018082	Decal, Safety Instructions: Lock Front Wheels... ..	1
140220	Decal, Warning: Do Not Operate.... ..	2
155007	Decal, HY-RAIL® Vehicle Completed By... ..	1
191761	Decal, Harsco Track Technologies	1
201564	Decal, Control Valve Operating Instructions	1
201565	Decal, Operating Instructions	1
201566	Decal, Operating Instructions	1

201536 MOUNTING BRACKET GROUP

PART NO	DESCRIPTION	QTY
201536	MOUNTING BRACKET GROUP	1
201348	Radiator Pipe	1
201476	Block.	2
201550	Axle Stop, Right	1
201551	Axle Stop, Left	1
201645	Shim	2
201646	Shim	8
201676	Cap Screw, 3/4-10 x 6" SST Hex Hd	2
201785	Block.	2
201787	Mounting Pin.	2
202414	Block.	2
202454	Plate	1
202459	HANGER ASSEMBLY, REAR	1
202306	Rubber Spring	1
202457	Hanger Bracket	1
202519	Plate Assembly Right	1
202520	Plate Assembly Left	1
202535	Hose, Radiator	1
202562	Shim	10
202563	Shim	10
202564	Shim	2
202568	HANGER ASSEMBLY, REAR	1
183875	Cap Screw, 1/2-13 x 4-1/2" GR 8 Hex Hd	1
202331	Hanger.	1
202565	Spring	1
202569	Spacer	1
202570	Bushing	1
F013500	Elastic Stop Nut, 1/2"-13	3
F018861	Cap Screw, 1/2-13 x 2-1/4" Hex Hd.	2
F024047	Washer	1
700561150	Cap Screw, 5/16-18 x 1-1/2" GR 8 Hex Hd.	1
F001362	Wrought Washer, 5/16".	8
F007062	Cap Screw, 1/4-20 x 4" GR 5 Hex Hd.	4
F012452	Elastic Stop Nut, 5/8"	8
F013588	Elastic Stop Nut, 1/4"-20.	4
F014344	Hex Nut, 3/4"-10 SST	4
F014476	Elastic Stop Nut, 5/16"	1
F019502	Cap Screw, 5/8-11 x 2-3/4" GR 8 Hex Hd.	4
F021137	Hardened Washer.	4
F023012	Hardened Washer.	16
F023386	Cap Screw, 1/2-13 x 1-1/2" GR 5 Hex Flg Hd.	4
F023743	Cap Screw, 5/8-11 x 5-1/2" GR 8 Hex Hd.	4
F026081	Hex Flg Nut, 1/2"-13 GR 8	4
024408	Front Unit Application Drawing	

203178 MOUNTING BRACKET GROUP

PART NO	DESCRIPTION	QTY
203178	MOUNTING BRACKET GROUP	1
201476	Block	2
201550	Axle Stop, Right	1
201551	Axle Stop, Left	1
201645	Shim	2
201646	Shim	8
201663	Radiator Hose Coupling	1
201664	Hose, Radiator	12
201676	Cap Screw, 3/4-10 x 6" SST Hex Hd	2
201785	Block	2
201787	Mounting Pin	2
202414	Block	2
202454	Plate	1
202459	HANGER ASSEMBLY, REAR	1
202306	Rubber Spring	1
202457	Hanger Bracket	1
202519	Plate Assembly Right	1
202520	Plate Assembly Left	1
202562	Shim	10
202563	Shim	10
202564	Shim	2
202568	HANGER ASSEMBLY, REAR	1
183875	Cap Screw, 1/2-13 x 4-1/2" GR 8 Hex Hd	1
202331	Hanger	1
202565	Spring	1
202569	Spacer	1
202570	Bushing	1
F013500	Elastic Stop Nut, 1/2"-13	3
F018861	Cap Screw, 1/2-13 x 2-1/4" Hex Hd	2
F024047	Washer	1
F001362	Wrought Washer, 5/16"	8
F007062	Cap Screw, 1/4-20 x 4" GR 5 Hex Hd	4
F011057	Hose Clamp	1
F012452	Elastic Stop Nut, 5/8"	8
F013588	Elastic Stop Nut, 1/4"-20	4
F014344	Hex Nut, 3/4"-10 SST	4
F019502	Cap Screw, 5/8-11 x 2-3/4" GR 8 Hex Hd	4
F021137	Hardened Washer	4
F023012	Hardened Washer	16
F023386	Cap Screw, 1/2-13 x 1-1/2" GR 5 Hex Flg Hd	4
F023743	Cap Screw, 5/8-11 x 5-1/2" GR 8 Hex Hd	4
F026081	Hex Flg Nut, 1/2"-13 GR 8	4
024602	Front Unit Application Drawing	

**SECTION 8 - VEHICLE APPLICATIONS
TABLE OF CONTENTS**

2004 FREIGHTLINER..... 8 - 2

2004 FREIGHTLINER M2 14,700 GAWR FRONT AXLE MBE ENGINE HR4000C1 FRONT HR4000A2 REAR	2004 FREIGHTLINER M2 14,700 GAWR FRONT AXLE CAT ENGINE HR4000C1 FRONT HR4000A2 REAR
---	---

REQUIRED GROUPS

Front Guide Wheel Unit	201492	201492
Mounting Brackets	201536	203178
Steering Lock	202549	202549
Application Drawing - Front	024408	024602

ACCESSORY GROUP OPTIONS

* Rail Sweeps	201580	201580
Truck Brake Connection	162114	162114
Hydraulic Power Pack - Full	137926	137926
Hydraulic Power Pack - Abbreviated	137927	137927
Sight Rod Kit And Extension	164574	164574
* Recommended Safety Option		

Limited Warranty

HARSCO TRACK TECHNOLOGIES products are designed to give high quality service and are manufactured from high grade material, by competent workmen under careful supervision. Harsco Track Technologies, Harsco Corporation warrants products of its manufacture to be free of defects in material and workmanship, under normal use and service for a period of six (6) months from date of delivery to the original user. The obligation of Harsco Track Technologies, Harsco Corporation under this warranty is limited to repairing or replacing at its factories, or other location designated by it, any part or parts thereof which are returned within 30 days of the date when failure occurs or defect is noted, with transportation charges prepaid, and which upon examination appears to the satisfaction of Harsco Track Technologies, Harsco Corporation to have been defective. Such free repair or replacement does not include transportation charges, or the cost of installing the new part or any other expense incident thereto. Harsco Track Technologies, Harsco Corporation will not be liable for other loss, damage, or expense directly or indirectly arising from the use of its products, nor will Harsco Track Technologies, Harsco Corporation be liable for special, incidental or consequential damages.

Ordinary wear and tear, and damage from abuse, misuse, neglect or alteration are not covered by this warranty. Harsco Track Technologies, Harsco Corporation assumes no liability for expenses incurred or repairs made outside its factories except by written consent. This warranty is null and void if instructions and operating procedures are not followed.

Equipment or parts not manufactured by this company, but which are furnished in connection with HARSCO TRACK TECHNOLOGIES products, are covered directly by the warranty of the manufacturer supplying them. However, Harsco Track Technologies, Harsco Corporation will assist in obtaining adjustment on such equipment or parts when necessary.

THIS WARRANTY IS IN LIEU OF ALL OTHER WARRANTIES EXPRESSED OR IMPLIED INCLUDING ANY IMPLIED WARRANTIES OF MERCHANTABILITY OR FITNESS FOR A PARTICULAR PURPOSE AND OF ANY OTHER OBLIGATION OR LIABILITY OF HARSCO TRACK TECHNOLOGIES, HARSCO CORPORATION.

Product Improvement Liability Disclaimer

HARSCO TRACK TECHNOLOGIES, HARSCO CORPORATION RESERVES THE RIGHT TO MAKE ANY CHANGES IN OR IMPROVEMENTS ON ITS PRODUCTS WITHOUT INCURRING ANY LIABILITY OR OBLIGATION WHATEVER AND WITHOUT BEING REQUIRED TO MAKE ANY CORRESPONDING CHANGES OR IMPROVEMENTS IN PRODUCTS PREVIOUSLY MANUFACTURED OR SOLD.

Hazardous Material Disclaimer

THE PARTS/ASSEMBLIES THAT ARE USED IN THIS PRODUCT ARE CLASSIFIED AS "ARTICLES" ACCORDING TO 29 CFR 1910.1200 (C). THEY ARE FORMED TO A SPECIFIC SHAPE OR DESIGN DURING MANUFACTURE, HAVE END USE FUNCTION DEPENDENT UPON THEIR SHAPE OR DESIGN, AND DO NOT RELEASE ANY HAZARDOUS CHEMICAL UNDER NORMAL CONDITIONS OF USE. ACCORDINGLY, WE ARE NOT REQUIRED TO SUPPLY MATERIAL SAFETY DATA SHEETS (MSDS) OR TO LABEL SHIPPING CONTAINERS FOR "ARTICLES". HOWEVER, LUBRICANTS, LIQUIDS, GASEOUS CHEMICALS AND SOLIDS USED IN OPERATION OR MAINTENANCE OF THE PRODUCT MAY REQUIRE THAT USER'S TAKE OCCUPATIONAL PROTECTIVE MEASURES. MSDS SHEETS FOR SUCH MATERIALS WILL BE SUPPLIED TO YOUR PURCHASING MANAGER/SAFETY DIRECTOR TO BE USED IN YOUR EMPLOYEE SAFETY TRAINING EDUCATION AND ENVIRONMENTAL HEALTH TRAINING.

HTT

Harsco Track Technologies

Harsco

HARSCO TRACK TECHNOLOGIES
HARSCO CORPORATION
415 North Main Street
Fairmont, Minnesota, 56031-1837 U.S.A.

BULLETIN 1442

Printed In U.S.A.

ISSUED 9 - 2004

© 2004 HARSCO TRACK TECHNOLOGIES, HARSCO CORPORATION