



www.harscorail.com

---

## SERVICE BULLETIN

### MAINTENANCE OF WAY EQUIPMENT

---

**DATE:** 12-2012

**BULLETIN NO:** 12-019

**TITLE:** Upper Structure Rework

**RATING:**

<input checked="" type="checkbox"/>	<b>DIRECTIVE</b> (Action Is Required)	<input type="checkbox"/>	<b>ALERT</b> (Potential Problem)
<input type="checkbox"/>	<b>INFORMATION</b> (Action Is Optional)	<input type="checkbox"/>	<b>PRODUCT IMPROVEMENT</b> (Enhance Product)

**PRODUCT SERIES / MODEL:** HR4000 Series B and HR4100 Series B  
Rear HY-RAIL® Guide Wheel Units

**SERIAL NO:** 60100 Through 63499

**SUMMARY:** Harsco Rail has become aware of a possible weld issue on the upper structure on certain HR4000 Series B and HR4100 Series B Rear HY-RAIL® Guide Wheel Units. On affected equipment, the involved weld could break and might result in a significant equipment failure that may cause property damage or personal injury. Harsco Rail is requesting that you review the serial number on your HR4000 Series B or HR4100 Series B Rear HY-RAIL® Guide Wheel Unit. If the serial number on your guide wheel unit is included in the group listed above, you should remove the vehicle from service immediately and transport it, in the manner indicated in the Removing Vehicle from Service instructions below, to the nearest approved HY-RAIL® guide wheel equipment repair facility. Harsco Rail has developed a procedure to be performed by an approved repair facility, that is set forth below.

**OPERATIONAL IMPACT:** The affected vehicle / equipment must be removed from service immediately and not be used on rail or driven on the highway until repairs are completed.

**ACTION:** Owners of HR4000 Series B or HR4100 Series B Rear HY-RAIL® Guide Wheel Units: Verify the serial number on your HR4000 Series B or HR4100 Series B Rear HY-RAIL® Guide Wheel Unit. The serial number plate is located on the upper structure of the unit. If the serial number is included in the group listed above, the vehicle should be removed from service immediately and transported in the manner indicated in the Removing Vehicle from Service instructions below, to the nearest approved HY-RAIL® guide wheel equipment repair facility.

## Removing Vehicle from Service

1. The affected vehicle / equipment must be removed from service. If the involved weld breaks during track or road travel, the lower components of the guide wheel unit could separate from the upper structure of the guide wheel unit and possibly result in a serious accident.
2. Owners should have the affected vehicles transported by flatbed or rollback recovery truck. If road travel is the only option, the HY-RAIL® guide wheel unit, including lower components, should first be secured to the chassis of the vehicle by use of a suitable load restraining device such as a chain, cable or binding strap. Once the guide wheel unit is secured, the vehicle can be driven to the nearest approved HY-RAIL® guide wheel equipment repair facility.

## Instructions for Reinforcing Guide Wheel Unit Weld



- **THE REPAIRS DESCRIBED BELOW SHOULD BE PREFORMED ONLY BY AN APPROVED HY-RAIL® GUIDE WHEEL EQUIPMENT REPAIR FACILITY. FAILURE TO HEED THIS WARNING COULD RESULT IN SEVERE BODILY INJURY.**

- Read through these instructions BEFORE performing work to ensure that you understand and have the necessary parts and equipment. Fully comply with these instructions to inspect and repair the guide wheel unit.
- Wedge Blocks, part number 5026188, needed for these repairs will be provided at no charge. Four wedge blocks for each affected guide wheel unit are required. Contact Harsco Rail Parts Sales to obtain the wedge blocks.

**CONTACT:**    Parts Sales:        (507) 235-7143  
                         Service:                (507) 235-7212 or (507) 235-7137

- The approved HY-RAIL® guide wheel equipment repair facility will be reimbursed at the standard labor rate for making the necessary repairs to the guide wheel unit.
  - Contact Nelson Carlson at: (803) 216-4048, Harsco Rail, with any questions about this Service Bulletin, the repairs or your HY-RAIL® guide wheel equipped vehicle.
1. Lower and lock the guide wheel unit in the rail position.
  2. Make sure the vehicle transmission is in PARK or NEUTRAL and the parking brakes are applied. Stop the vehicle engine. Lock-out / Tag-out vehicle ignition switch.
  3. Depressurize hydraulic and air systems.
  4. Disconnect battery cables and all other sensitive electrical components before welding on the unit to help prevent damage to electrical components.

**Instructions for Reinforcing Guide Wheel Unit Weld - See Figures 1 and 2**

5. Tubes (1) are welded to the upper structure plate (2) along the length of the tubes at position (3).

FIGURE 1  
TYPICAL UPPER STRUCTURE

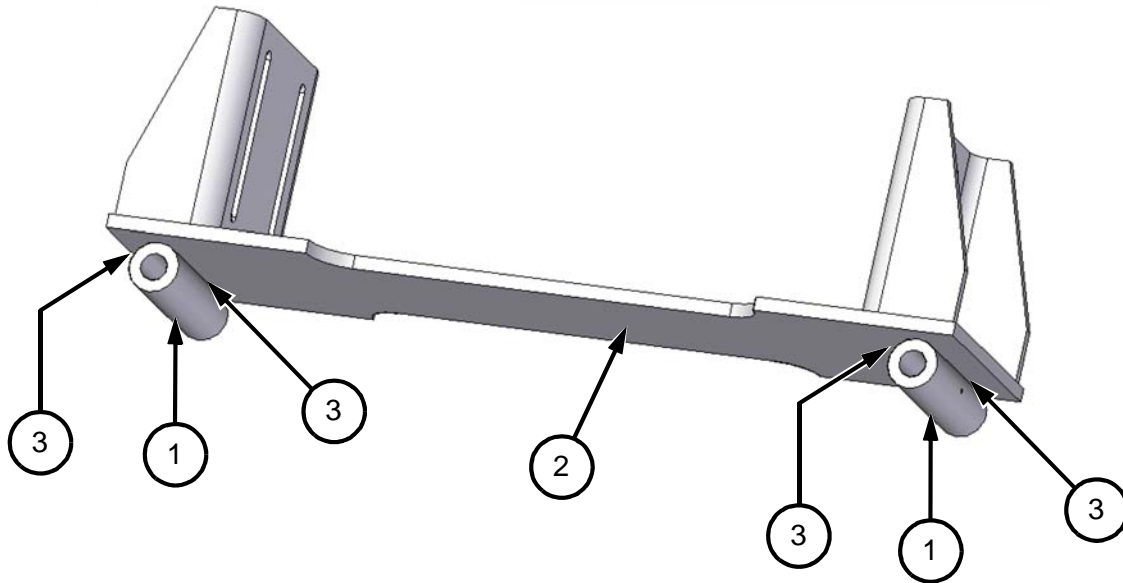

6. Clean dirt and grease from the area along the existing weld area (3). Fit wedge block (4) against the tube (1) and upper structure plate (2). Make sure the wedge block fits tightly against tube (1) and upper structure plate (2). If not, use a grinder to remove any existing weld that may be holding the wedge block away.
7. Using a wire brush or grinder, remove paint, dirt, grease, etc. from the area along the tube (1) and upper structure plate (2) where the wedge blocks (4) are going to be welded.

FIGURE 2  
TYPICAL UPPER STRUCTURE WITH WEDGE BLOCKS

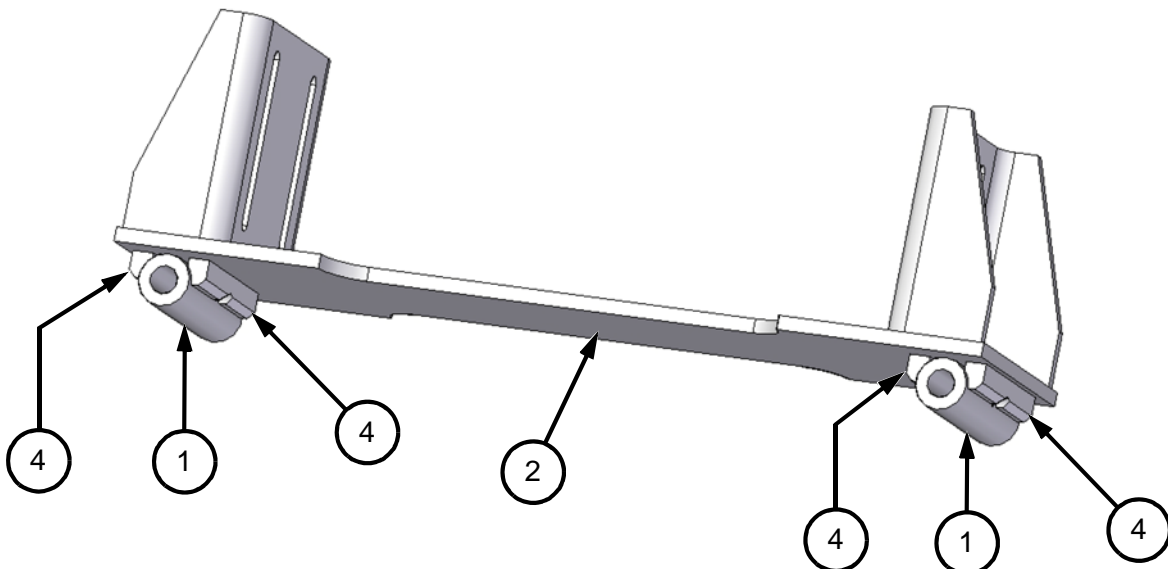

**Instructions for Reinforcing Guide Wheel Unit Weld** - See Figures 3 and 4

8. Fit and clamp the wedge blocks (4) in place. Make sure they fit tightly against tube (1) and upper structure plate (2).



- **ALL WELDING PERFORMED ON THE HY-RAIL® GUIDE WHEEL UNIT MUST BE COMPLETED BY AN AMERICAN WELDING SOCIETY (AWS) CERTIFIED WELDER. FAILURE TO HEED THIS WARNING COULD RESULT IN SEVERE BODILY INJURY.**

9. Clamp the welder ground cable as close to the welding point as possible. If necessary, disconnect battery cables and all other sensitive electrical components before welding on the unit to help prevent damage to electrical components.
10. Weld the four wedge blocks (4) in place using the dimensions and weld symbols as shown in Figure 4.
11. All welds must be inspected by a AWS certified welding inspector.
12. Using a digital camera, take at least three photographs of each completed weld and retain photographs to be provided to Harsco Rail as part of fulfillment of this Service Bulletin.
13. Paint the welded areas after welding to help prevent rust.

FIGURE 3  
WELDING WEDGE BLOCKS

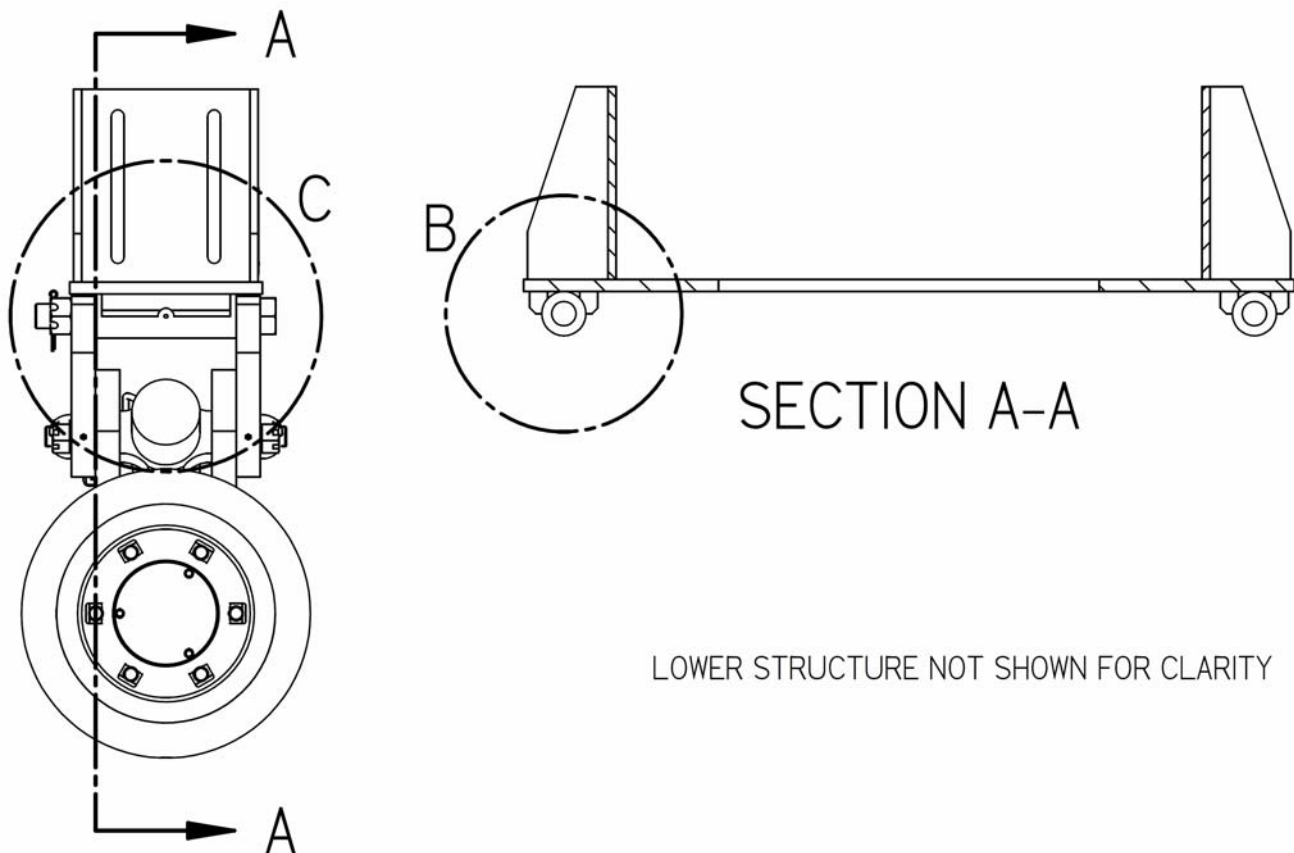

LOWER STRUCTURE NOT SHOWN FOR CLARITY

**Instructions for Reinforcing Guide Wheel Unit Weld**

FIGURE 4  
WELDING WEDGE BLOCKS

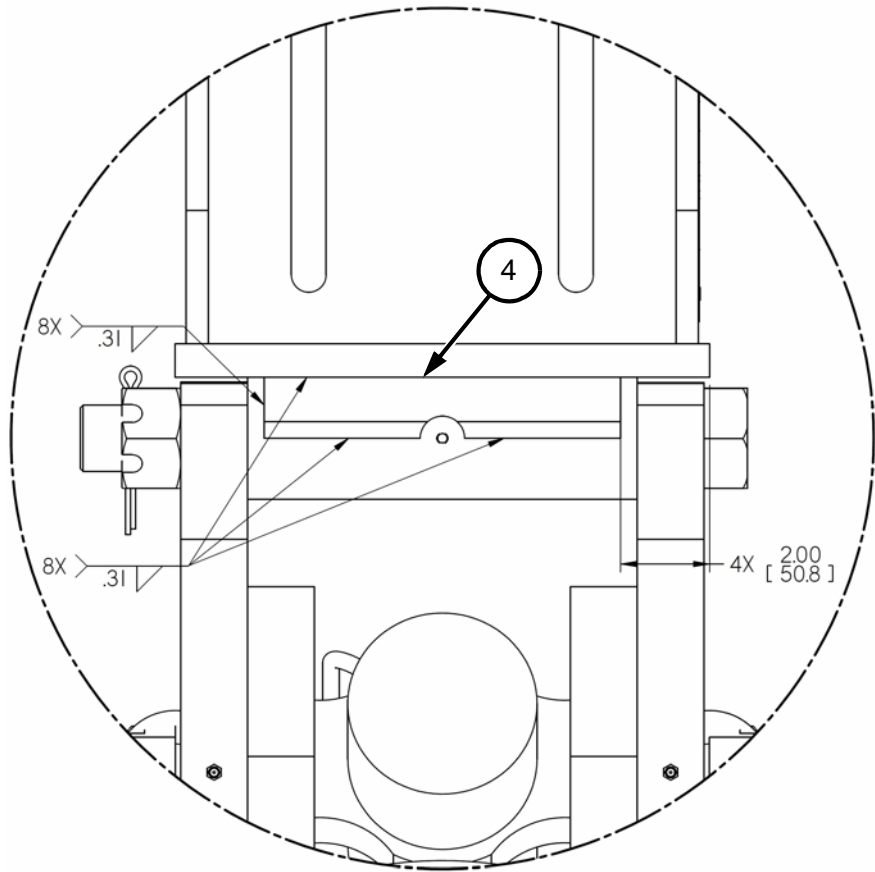

DETAIL C

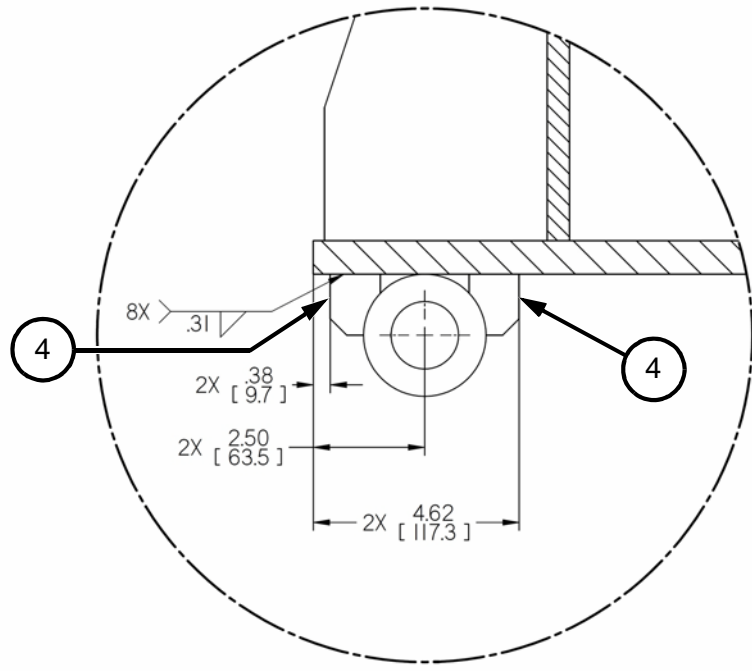

DETAIL B

**Safety Information**

- FOLLOW APPLICABLE RAILROAD LOCKOUT - TAGOUT PROCEDURES TO DISABLE ENERGY SOURCES WHEN PERFORMING MAINTENANCE, MAKING ADJUSTMENTS OR REPAIRS TO THE VEHICLE OR EQUIPMENT.
- ALL WELDING PERFORMED ON THE HY-RAIL® GUIDE WHEEL UNIT MUST BE COMPLETED BY AN AMERICAN WELDING SOCIETY (AWS) CERTIFIED WELDER.

**FAILURE TO HEED THESE WARNINGS COULD RESULT IN SEVERE BODILY INJURY.**

**© 2012 HARSCO CORPORATION, ALL RIGHTS RESERVED**

415 North Main Street  
Fairmont, MN  
56031-1837  
Tel: (507) 235-3361  
Fax: (507) 235-7370

401 Edmund Road, Box 20  
Cayce-West Columbia, SC  
29171-0020  
Tel: (803) 822-9160  
Fax: (803) 822-7471

200 South Jackson Road  
Ludington, MI  
49431  
Tel: (231) 843-3431  
Fax: (231) 843-1644

Printed In USA