



Harsco Track Technologies

Harsco

www.harscotrack.com

SERVICE BULLETIN MAINTENANCE OF WAY EQUIPMENT

DATE: 1-3-2003 **BULLETIN NO:** 02-031

TITLE: 200378 REAR SIDE BARS AND BRACES GROUP

RATING:

<input type="checkbox"/>	DIRECTIVE (Action Is Required)	<input type="checkbox"/>	ALERT (Potential Problem)
<input type="checkbox"/>	INFORMATION (Action Is Optional)	<input checked="" type="checkbox"/>	PRODUCT IMPROVEMENT (Enhance Product)

PRODUCT SERIES / MODEL: All Ford F450 and F550 4X2 and 4X4 Vehicles Equipped with HR2000 Series B2 Rear HY-RAIL® Guide Wheel Equipment

SERIAL NO: All Rear HR2000 Models B2

SUMMARY: Under certain load applications, stress cracks have been found in the rear guide wheel unit mounting side bars on some Ford F450 and F550 vehicles. The existing rear side bars can be replaced with new stronger rear side bars and cross braces to provide additional strength for the rear guide wheel unit. The new rear side bars are also longer to provide additional adjustment when setting the rear guide wheel unit height and weight.

OPERATIONAL IMPACT: To extend the operational life of the rear guide wheel unit by strengthening the rear side bars and adding cross braces, and also providing additional height and weight adjustment.

ACTION: Order one Group part # 200378 to replace the existing rear side bars of each rear guide wheel unit.

CONTACT: To order the Rear Side Bars and Braces Group, please contact the HY-RAIL® Parts Department at the Fairmont, MN. facility, (507) 235-7143.

SAFETY INFORMATION

- **FOLLOW APPLICABLE RAILROAD LOCKOUT - TAGOUT PROCEDURE TO REMOVE ALL ENERGY SOURCES FROM VEHICLE AND RAIL GUIDE WHEEL EQUIPMENT. FAILURE TO COMPLY COULD RESULT IN SEVERE BODILY INJURY.**

GROUP INSTALLATION - See Figure 1

1. Remove the rear guide wheel unit from the existing rear side bars that are attached to vehicle frame. Discard the existing mounting hardware, as new mounting hardware is provided.
2. Lower the rear fuel tank by removing the two metric bolts that hold the skid plate to gain access to the mounting bolts that secure the existing rear side bars to the vehicle frame. Be careful not to pinch the fuel line. Then remove the two existing rear side bars from the vehicle frame. Discard the existing rear side bars and mounting hardware as new side bars and mounting hardware are provided.
3. Install the two new rear side bars (3) to the vehicle frame using the new mounting hardware (2-8-9 and 6-7-10).
4. Raise the rear fuel tank and re-secure with the two metric bolts that hold the skid plate. Be careful not to pinch the fuel line.
5. Install the rear guide wheel unit to the two new rear side bars (4) using new mounting hardware (2-8-9) and new shims (1) as required.
6. Slide the inner brace end (4) inside of the outer brace end (5). Install the ends of the two new cross brace assemblies at holes A and B on both sides of the vehicle rear frame and rear guide wheel unit using the new mounting hardware (2-8-9) already installed. After the proper brace length is set, weld the inner and outer brace ends (4-5) together per the weld symbol shown.
7. Tighten all mounting hardware to the proper torque listed in the Bolt Torque Charts of your Operator's, Service and Parts Manual, Section 6 - Appendices.
8. Align the rear guide wheel unit and set the height and weight per the Guide Wheel Alignment Procedure listed in your Operator's, Service and Parts Manual, Section 3 - Adjustments.

GROUP INSTALLATION - See Figure 1

SE02A209A-1

**FIGURE 1
GROUP INSTALLATION**

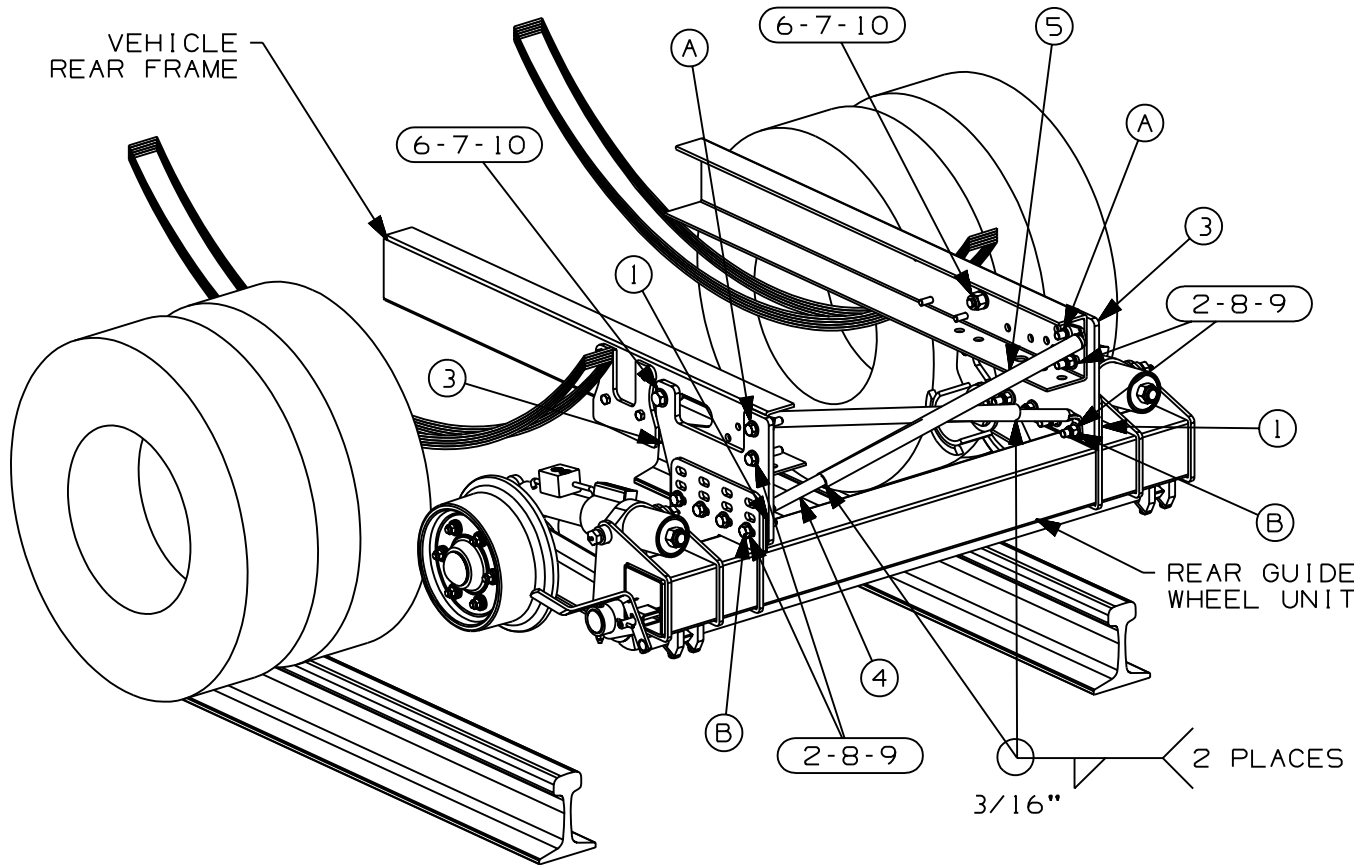

GROUP PARTS LIST - See Figure 1

ITEM	PART NO	DESCRIPTION	QTY
	200378	REAR SIDE BARS AND BRACES GROUP.....	1
1	181524	Shim (use as required)	4
2	188306	Cap Screw, 5/8"-11 x 3" Hex Head Grade 8.....	12
3	200377	Side Bar, Rear.....	2
4	200396	Brace End, Inner.....	2
5	200397	Brace End, Outer.....	2
6	700666075	Hex Lock Nut, 3/4"-10.....	2
7	F021137	Hardened Washer, 3/4".....	4
8	F023012	Hardened Washer, 5/8".....	24
9	F017188	Hex Lock Nut, 5/8"-11.....	12
10	F020458	Cap Screw, 3/4"-10 x 2-1/2" Hex Head Grade 8.....	2

© 2002 HARSCO TRACK TECHNOLOGIES, HARSCO CORPORATION

415 North Main Street
Fairmont, MN
56031-1837
Tel: (507) 235-3361
Fax: (507) 235-7370

2401 Edmund Road, Box 20
Cayce-West Columbia, SC
29171-0020
Tel: (803) 822-9160
Fax: (803) 822-7471

200 South Jackson Road
Ludington, MI
49431
Tel: (231) 843-3431
Fax: (231) 843-4830

Printed In U.S.A.