



# Harsco Track Technologies

Harsco

www.harscotrack.com

---

## SERVICE BULLETIN MAINTENANCE OF WAY EQUIPMENT

---

**DATE:** 9-25-2003 / Revised 1-15-2004 **BULLETIN NO:** 03-011

**TITLE:** 201275 WHEEL SPACER MODIFICATION GROUP

**RATING:**

<input type="checkbox"/> <b>DIRECTIVE</b> (Action Is Required)	<input type="checkbox"/> <b>ALERT</b> (Potential Problem)
<input type="checkbox"/> <b>INFORMATION</b> (Action Is Optional)	<input checked="" type="checkbox"/> <b>PRODUCT IMPROVEMENT</b> (Enhance Product)

**PRODUCT SERIES / MODEL:** All 1993 - 1998 Chevrolet 4X2 Vehicles, 8,600 GVW Series 2500 and 9,200 GVW Series 3500 SRW, Equipped With HY-RAIL® Guide Wheel Equipment Series 0307, HR0307A, HR1000A or HR1500B Rail Pilot Units.

**SERIAL NO:** All 0307 Models - All HR0307 Models A1 - All HR1000 Models A1 - All HR1500 Models B

**SUMMARY:** The above 1993 -1998 Chevrolet 4X2 vehicles equipped with guide wheel equipment were supplied with 19-1/2" x 6" wheel rims part #137670. These wheel rims were mounted on the vehicle hubs using wheel spacers and conical wheel nuts part #F016868 that piloted off the wheel bolt circle. New wheel spacers are now available to convert the existing wheel modification to a hub piloted mounting system that uses locking flange nuts part #201752 to secure the wheel rims and wheel spacers to the vehicle hubs.

**OPERATIONAL IMPACT:** To help prevent the possibility of the vehicle's wheel rims from becoming loose.

**ACTION:** Order one Group part #201275 to replace the existing wheel modification for each vehicle.

**CONTACT:** If you have any questions or if we can be of any service, please contact the HY-RAIL® Parts Department at the Fairmont, MN. facility, (507) 235-7143 or (507) 235-7134.

**SAFETY INFORMATION**

- n **IT IS THE RESPONSIBILITY OF THE UP-FITTER OR REPAIR FACILITY TO ENSURE THESE INSPECTIONS AND MODIFICATIONS ARE DONE CORRECTLY TO OBTAIN SATISFACTORY VEHICLE PERFORMANCE.**
- n **FOLLOW APPLICABLE RAILROAD LOCKOUT - TAGOUT PROCEDURE TO REMOVE ALL ENERGY SOURCES FROM VEHICLE AND RAIL GUIDE WHEEL EQUIPMENT.**
- n **ANY JACK, JACK STANDS, HOIST, ETC. USED MUST BE RATED TO LIFT WEIGHT OF VEHICLE.**

**FAILURE TO COMPLY COULD RESULT IN SEVERE BODILY INJURY.**

**WHEEL SPACER MODIFICATION GROUP INSTALLATION - See Figure 1****Vehicle Front Wheels**

1. Remove the wheel rim and existing wheel spacer from the vehicle front hub. Discard the existing wheel spacer and conical wheel nuts; they will not be re-used.
2. Remove any rust, dirt, grease, etc. from the mating surface of the vehicle front hub.
3. Inspect all wheel studs (2) in the vehicle front hub for any cracks, wear, damage, etc. and ensure that there is 1-3/8 inch (34.93 mm) or more of the studs protruding thru the front hub. If a wheel stud protrudes less than 1-3/8 inch (34.93 mm) or is cracked, worn, damaged, etc., replace the front wheel stud with a new stud (2).
4. Install the new wheel spacer (1) on the vehicle front hub.
5. Inspect the wheel rim for any cracks, wear, damage, etc. Remove the wheel rim from service if any cracks, wear, damage, etc. is evident. Clean the wheel rim mating surface of any rust, dirt, grease, etc.
6. Re-install the wheel rim to the vehicle front hub and wheel spacer (1), and secure with eight new locking flange wheel nuts (4). Torque the new locking flange wheel nuts (4) to 140 Ft-Lbs.
7. Remove the existing wheel torque decal from the wheel rim. Thoroughly clean the area on the rim where the decal was removed of any rust, dirt, grease, etc. Then install the new wheel torque decal (5) on the wheel rim.
8. Repeat procedure for the other front wheel on the vehicle.

**WHEEL SPACER MODIFICATION GROUP INSTALLATION**

**FIGURE 1**  
**WHEEL SPACER MODIFICATION GROUP INSTALLATION**

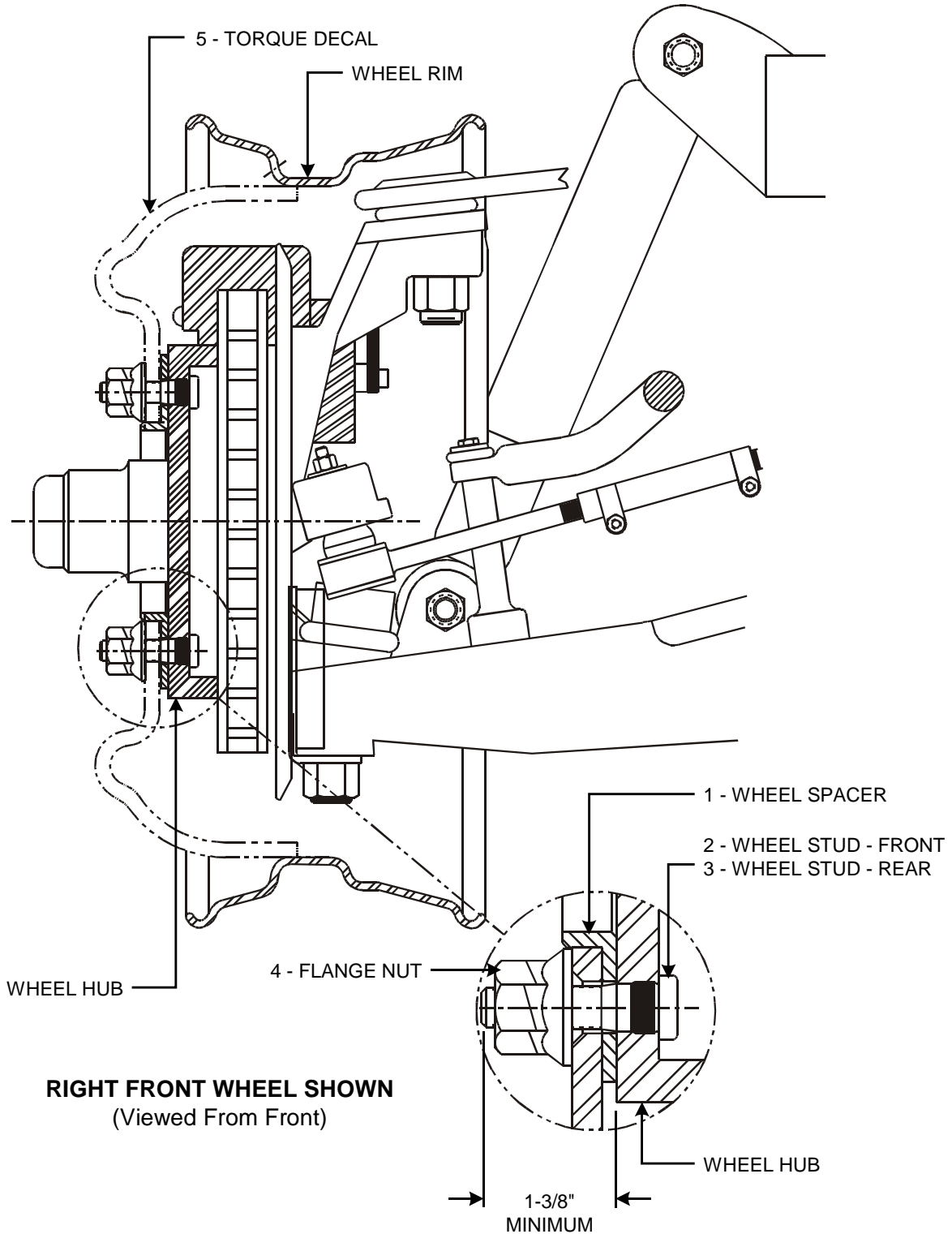

**WHEEL SPACER MODIFICATION GROUP INSTALLATION - See Figure 1****Vehicle Rear Wheels**

9. Remove the wheel rim and existing wheel spacer from the vehicle rear hub. Discard the existing wheel spacer and conical wheel nuts; they will not be re-used.
10. Remove any rust, dirt, grease, etc. from the mating surface of the vehicle rear hub.
11. Inspect all wheel studs (3) in the vehicle rear hub for any cracks, wear, damage, etc. and ensure that there is 1-3/8 inch (34.93 mm) or more of the studs protruding thru the rear hub. If a wheel stud protrudes less than 1-3/8 inch (34.93 mm) or is cracked, worn, damaged, etc., replace the rear wheel stud with a new stud (3).
12. Install the new wheel spacer (1) on the vehicle rear hub.
13. Inspect the wheel rim for any cracks, wear, damage, etc. Remove the wheel rim from service if any cracks, wear, damage, etc. is evident. Clean the wheel rim mating surface of any rust, dirt, grease, etc.
14. Re-install the wheel rim to the vehicle rear hub and wheel spacer (1), and secure with eight new locking flange wheel nuts (4). Torque the new locking flange wheel nuts (4) to 140 Ft-Lbs.
15. Remove the existing wheel torque decal from the wheel rim. Thoroughly clean the area on the rim where the decal was removed of any rust, dirt, grease, etc. Then install the new wheel torque decal (5) on the wheel rim.
16. Repeat procedure for the other rear wheel on the vehicle.

**Vehicle Spare Wheel**

17. Remove the spare wheel rim from the vehicle spare carrier.
18. Remove the existing wheel torque decal from the spare wheel rim. Thoroughly clean the area on the rim where the decal was removed of any rust, dirt, grease, etc. Then install the new wheel torque decal (5) on the spare wheel rim.
19. Re-install the spare wheel rim on the vehicle spare carrier.
20. Be sure to inspect the steering stops. Go to Step. 21. Steering Stops Inspection.

---

## STEERING STOPS INSPECTION

21. Inspect the steering stops on both the left and right front vehicle wheels.
  - 21.1 If the steering stops are missing, bent, damaged, etc., replace the steering stops.
  - 21.2 If the steering stop fasteners are loose, tighten the fasteners securely.
  - 21.3 If the steering stop fasteners and/or bar are missing, bent, damaged, etc., replace the components.
22. Lower the vehicle back down to the ground.
23. Turn the vehicle front wheels both hard left and hard right. Check the vehicle's front wheels (tires and rims) for contact with any fixed part of the vehicle in both directions. There must be a minimum of 3/8 - 1/2 inch (9.53 - 12.70 mm) of clearance or any contact with any fixed part of the vehicle.
  - 23.1 If there is 3/8 - 1/2 inch (9.53 - 12.70 mm) of clearance in both directions, the steering stops are set correctly.
  - 23.2 If there is less than 3/8 - 1/2 inch (9.53 - 12.70 mm) of clearance in either or both directions, the steering stops must be modified. Go to Step 24. - Steering Stops Modification.
  - 23.3 If there is more than 5/8 inch (15.88 mm) of clearance, the steering stops can be modified to decrease the turning radius of the vehicle. Go to Step 24. Steering Stops Modification.

## STEERING STOPS MODIFICATION

24. If there was more than 5/8 inch (15.88 mm) of clearance, use a grinder to remove material from the surface of the steering stop that makes contact with the existing stop of the vehicle wheel arm. DO NOT remove too much material before rechecking the steering stop clearance. Then go back to Step 23 to repeat the Steering Stops Inspection Procedure.
25. **Important:** Before doing any welding on the vehicle, disconnect all electrical cables from the battery and from the alternator.
26. Thoroughly clean the contact area of the steering stop surface of all dirt, grease, rust, etc. where material (not supplied) will be welded to.
27. If there was less than 3/8 - 1/2 inch (9.53 - 12.70 mm) of clearance or any contact at all, weld a piece of suitable material (thickness and length) to the surface of the steering stop that makes contact with the existing stop of the vehicle wheel arm. Then go back to Step 23 to repeat the Steering Stops Inspection Procedure.

**WHEEL SPACER MODIFICATION GROUP PARTS LIST - See Figure 1**

ITEM	PART NO	DESCRIPTION	QTY
	201275	WHEEL SPACER MODIFICATION GROUP . . . . .	1
1	171051	Wheel Spacer. . . . .	4
2	164036	Wheel Stud - Front. . . . .	16
3	201249	Wheel Stud - Rear . . . . .	16
4	201752	Wheel Flange Nut . . . . .	32
5	170774	Wheel Torque Decal . . . . .	5

**© 2003 HARSCO TRACK TECHNOLOGIES, HARSCO CORPORATION**

415 North Main Street  
 Fairmont, MN  
 56031-1837  
 Tel: (507) 235-3361  
 Fax: (507) 235-7370

2401 Edmund Road, Box 20  
 Cayce-West Columbia, SC  
 29171-0020  
 Tel: (803) 822-9160  
 Fax: (803) 822-7471

200 South Jackson Road  
 Ludington, MI  
 49431  
 Tel: (231) 843-3431  
 Fax: (231) 843-1644