

---

## SERVICE BULLETIN

### MAINTENANCE OF WAY EQUIPMENT

---

**DATE:** 01 - 2025

**BULLETIN NO:** SBUS000128-25

**TITLE:** Replacement of Hardware on HR1500 Ford F250

**RATING:**

**DIRECTIVE**  
(Action Is Required)

**ALERT**  
(Potential Problem)

**INFORMATION**  
(Action Is Optional)

**PRODUCT IMPROVEMENT**  
(Enhance Product)

**PRODUCT SERIES / MODEL:** 2023-2025 Ford F250/F350 Pickup Trucks with R1500C and HR1500D Series Hy-Rail® Guide Wheel Units Rear Mounting Kit (5067512) installed.00 Tamper

**SERIAL NO:** NA

**SUMMARY:** The mounting bolts supplied with Rear Install kit (5067512) for 2023-2024 Ford Pickup trucks are too small (M18) for the threaded nuts (M20) being utilized in the truck for these model years. Verify install is correct and change bolts if necessary.

**OPERATIONAL IMPACT:**

If incorrect fasteners were installed, the mounting could become unstable and increased risk of derailment or rail gear damage could occur.

**ACTION:** Inspect all vehicles built to confirm fastener size is correct and replace if necessary.

**CONTACT:** If you have any questions or if we can be of any service, please contact:

Harsco Rail Parts Department

Phone: 803-822-7406

Email: RA\_HTTPUS\_PARTS@harsco.com

Connor Budd

Phone: 800-800-6410

Email: CBUDD@Harsco.com

**SAFETY INFORMATION**

- Follow applicable railroad lockout - tagout procedure to remove machine from energy source. Failure to comply could result in severe bodily injury.

**Instructions:**

Ford changed their tow hitch mounting bolts and nuts from M18 to M20 in the 2023 Model Year. The Harsco Mounting Kits for these years were still supplied with the M18 bolts. If these M18 bolts were used and assembled with the Ford factory M20 nuts, the mounting would not be secured properly and could be at risk of derailment and damage.

**Rail Guide Wheel Rear Mounting Inspection / Repair Procedure**

1. Record serial numbers for front and rear units as well as any other identification information.
2. Inspect the truck frame, rail guide wheel unit, and rear mounting brackets for any signs of damage. If damage is found, replace or repair as needed.
3. Inspect the mounting fasteners to ensure they are proper size for the nuts and have been properly secured.
4. If the bolts are not correct, replace the bolts with new bolts P/N 252566-89 supplied or procured locally (M20-2.5 x 60mm Class 10.9 Hex Head Bolt).
5. Remove 1 bolt at a time and replace with correct bolt applying Blue Loctite and torque to 200 ft-lbs until all 8 bolts (w/o Tow Hitch) or all 12 bolts (with tow hitch) have been replaced.

**Replacement Parts**

5069322 (M18-2.5x60mm CL10.9) replaced with: 252566-89 (M20-2.5x60mm CL10.9)  
(SEE ATTACHED DRAWING)

**© 2024 HARSCO RAIL, LLC, ALL RIGHTS RESERVED**

306 West 4th Street  
Fairmont, MN  
56031-1837  
Tel: (507) 235-7376  
Parts: (800) 800-6410  
Fax: (507) 235-7372

2401 Edmund Road, Box 20  
Cayce-West Columbia, SC  
29171-0020  
Tel: (803) 822-7420  
Parts: (800) 800-6410  
Fax: (803) 822-7403

1200 Conrad Industrial Dr.  
Ludington, MI  
49431  
Tel: (231) 843-3431  
Parts: (800) 800-6410  
Fax: (231) 843-1644

Printed In USA

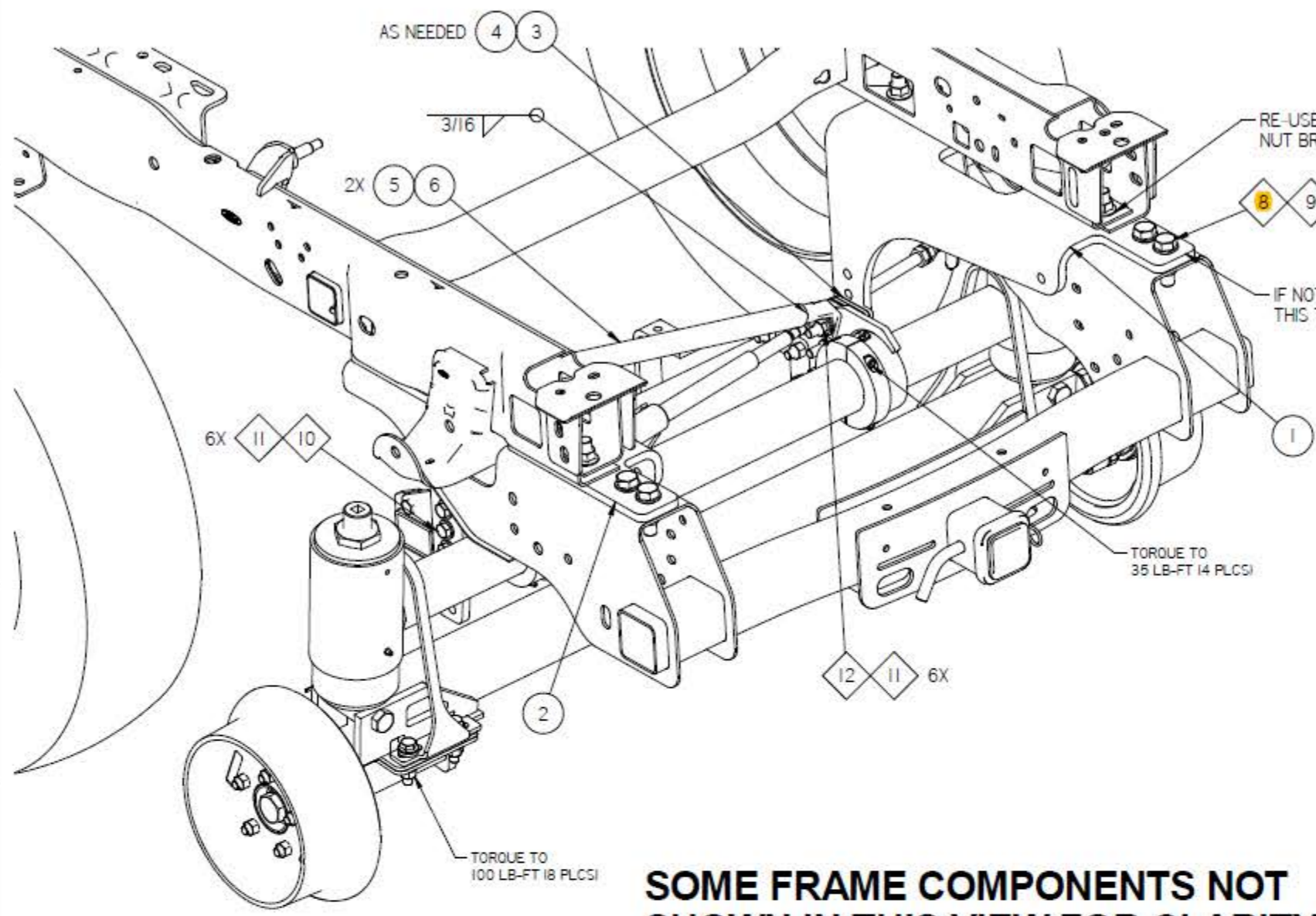

RE-USE HITCH MOUNTING NUT BRACKETS (6 PLCS)

APPLY BLUE LOCTITE TORQUE TO 200 FT-LBS

IF NOT USING HITCH THIS TAB CAN BE REMOVED

TORQUE TO 35 LB-FT (4 PLCS)

TORQUE TO 100 LB-FT (8 PLCS)

**SOME FRAME COMPONENTS NOT SHOWN IN THIS VIEW FOR CLARITY.**

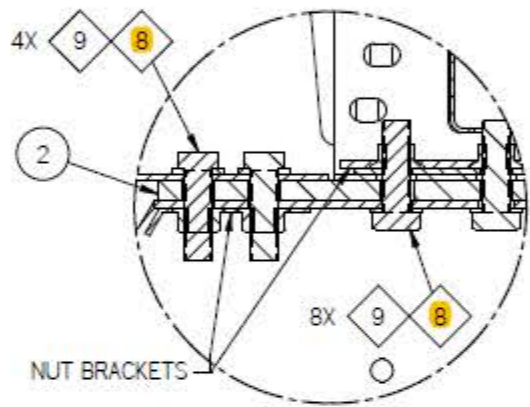

DETAIL B

**REFERENCE DATA**

WITH THE VEHICLE AT CURB WEIGHT AND THE RAIL GEAR IN HIGHWAY POSITION, THE DISTANCE FROM THE CENTER OF THE CROSS TUBE TO THE GROUND IS: 13.1/2" INCHES.

THIS MEASUREMENT IS FOR PRELIMINARY SETUP ONLY AND MAY NEED TO BE RE-ADJUSTED TO ACHIEVE PROPER GUIDE WHEEL LOAD.

GUIDE WHEEL LOAD AT CURB WEIGHT IS: 500 ± 25 LBS.

DISTANCE BETWEEN GUIDE WHEEL FLANGES IS: 53.3/16" TO 53.5/8".

PUMP MOUNTING BRACKETS ON PILOT UNITS ARE PROVIDED ONLY FOR SUGGESTED LOCATIONS.

UPFITTERS ARE RESPONSIBLE FOR LOCATING PUMPS TO THE SATISFACTION OF THE CUSTOMER.

HARSCO RAIL RECOMMENDS A 4 POINT ALIGNMENT AND HEADLIGHT AIM ADJUSTMENT AFTER INSTALLATION OF RAILGEAR PRIOR TO SETTING RAILGEAR WEIGHTS. FAILURE TO RESET FRONT WHEEL ALIGNMENT MAY CAUSE PREMATURE OR UNEVEN TIRE WEAR. FOLLOW OEM SPECIFICATION FOR PROPER ALIGNMENT.

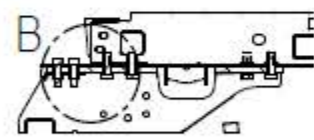
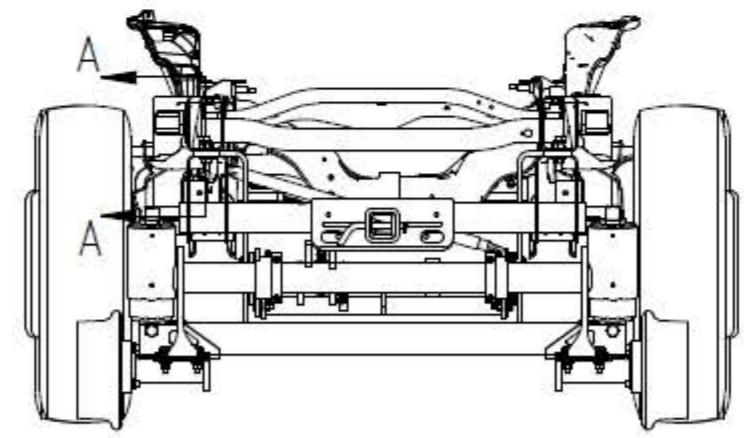
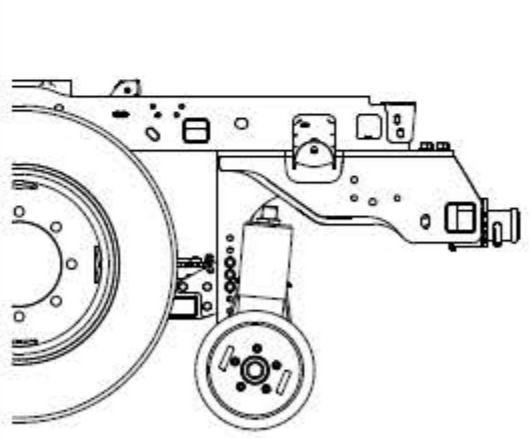

SECTION A-A

ITEM	PART NO	QTY	DESCRIPTION
1	5067621	1	HRI500 REAR PASSENGER SIDE BAR
2	5067622	1	HRI500 REAR DRIVERS SIDE BAR
3	196378	10	SHIM
4	196377	8	SHIM
5	163634	2	BRACE END
6	163636	2	BRACE END
7	5075160	1	HARDWARE KIT FOR 5067512
8	5069322	0	BOLT, M18X2.5X60, CL10.9 P
9	252048-8	0	WASHER, FLAT, M18, DIN125, HARD
10	252272-229	0	SCREW -HHC, GRADE 8, .50-13 X 3.50 LG
11	F024602	0	WASHER, FLAT, 1/2", HARDENED
12	252275-813	0	LOCKNUT- GRADE 8, .50-13

7 HARDWARE KIT INCLUDES ALL ITEMS MARKED

**PILOT UNIT INSTALL INSTRUCTIONS**

- REMOVE BUMPER AND TRAILER HITCH FROM VEHICLE. \*\* TRAILER HITCH MAY BE USED, BUT ALL LIABILITY RELIES ON THE UPFITTER. TRAILER HITCH (IF USED) MAY NEED TO BE MODIFIED TO FIT AND/OR MAY REQUIRE ADDITIONAL HARDWARE OTHER THAN WHAT IS SUPPLIED BY HARSCO RAIL AND WILL BE THE RESPONSIBILITY OF THE UPFITTER TO SUPPLY.
- ATTACH SIDE BARS BETWEEN HITCH AND FRAME WITH FASTENERS AS SHOWN. IF HITCH IS REMOVED, SIDE BARS CAN STILL BE USED WITHOUT ANY ISSUES.
- MAKE SURE THAT BOTH SIDE BARS ARE PARALLEL WITH EACH OTHER AND TIGHTEN FASTENERS.
- MOUNT PILOT UNIT TO SIDE BARS USING SHIMS AS NECESSARY BETWEEN SIDE BARS AND CROSS TUBE ASSEMBLY AND FASTEN IN PLACE WITH FASTENERS SHOWN.
- MODIFY TAILPIPE AS REQUIRED. FOLLOW OEM RECCOMENDATIONS/SERVICE BULLETIN FOR MODIFICATIONS OF DIESEL EXHAUST SYSTEMS. MAKE SURE THERE IS CLEARANCE BETWEEN TAILPIPE AND RAIL WHEEL IN HIGHWAY AND RAIL POSITION. ADDITIONAL HEAT SHIELDING MAY BE REQUIRED.
- TORQUE ALL FASTENERS TO VALUES RECOMMENDED IN OPERATOR'S SERVICE AND PARTS MANUAL.
- IF OEM BUMPER IS BEING RE-USED, MODIFY TO ALLOW CLEARANCE FOR RAILGEAR IN BOTH HIGHWAY AND RAIL POSITIONS.
- AFTER APPLICATION IS COMPLETE, RAIL EQUIPMENT MUST BE ALIGNED. SEE OPERATOR'S SERVICE AND PARTS MANUAL FOR ALIGNMENT PROCEDURES.
- AFTER RAIL EQUIPMENT HAS BEEN ALIGNED AND TRACKED, WELD CROSS BRACES 163634 AND 163636 TOGETHER WHEN APPROPRIATE LENGTH IS ACHIEVED BETWEEN FRAME AND SIDEBAR. MINIMUM OF ONE CROSS BRACE IS REQUIRED IN THIS APPLICATION.

**IMPORTANT! Please Read!**  
**Statement of Responsibility and Warranty:** HARSCO makes every effort to produce and update all application instructional drawings to be correct and accurate. It is also the responsibility of the applicator to correctly install all parts as noted on the drawing to achieve a quality application. HARSCO is not responsible for improper installations, errors, misunderstanding, or vehicle design/model changes that often occur without notice. HARSCO warrants only parts not labor. The applicator must use practical and reasonable shop practices to achieve a quality application at all times in all circumstances. If there is any questions or concern with anything on this drawing contact HARSCO personnel.

CONFIDENTIAL  
 © 2016 HARSCO CORPORATION. ALL RIGHTS RESERVED. THIS DRAWING OR DOCUMENT IS THE PROPERTY OF HARSCO AND EMBODIES CONFIDENTIAL INFORMATION, TRADE SECRET INFORMATION AND/OR KNOW-HOW THAT IS THE PROPERTY OF HARSCO. BY ACCEPTING THIS DRAWING OR DOCUMENT, THE RECIPIENT AGREES (1) NOT TO PROVIDE, OR OTHERWISE MAKE AVAILABLE, THE DRAWING OR DOCUMENT, OR ANY INFORMATION OR KNOW-HOW EMBODIED THEREIN, TO ANY THIRD PARTY AND (2) NOT TO REPRODUCE OR USE THE DRAWING OR DOCUMENT TO MANUFACTURE ANY APPARATUS OR DEVICE, WITHOUT THE PRIOR WRITTEN AUTHORIZATION OF HARSCO.

REV	DATE	DESCRIPTION	BY	CHKD
1	08/11/16	NEW RELEASE	JWW	JWW
2	10/18/16	252272-229 WAS F001791, 252275-813 WAS F019800, ADD 5069322, 252048-8, ADD TORQUE, ADD DETAIL B, REVISE NOTE.	JWW	JWW
3	12/02/16	UPDATE IT 9 DESCRIPTION	JWW	JWW
4	05/01/17	CREATE FASTENER KIT, UPDATE NOTES	JWW	JWW

DR	DATE	DESCRIPTION	BY	CHKD
JWW	08/11/16	HR1500C1 F350 4X4 REAR MTG	JWW	JWW
JWW	10/18/16	252272-229 WAS F001791, 252275-813 WAS F019800, ADD 5069322, 252048-8, ADD TORQUE, ADD DETAIL B, REVISE NOTE.	JWW	JWW
JWW	12/02/16	UPDATE IT 9 DESCRIPTION	JWW	JWW
JWW	05/01/17	SOLID EDGE DRAWING	JWW	JWW

2017 F250/350 4X2 4X4 PICKUP [mm]  
**HARSCO RAIL**  
 5067512  
 1 of 1